



MINI-CRAWLER CRANE

MODEL

URW706C2E SERIES

OPERATION & MAINTENANCE MANUAL

FURUKAWA UNIC CORPORATION

HEAD OFFICE : Nihonbashi nishikawa Bldg, 5-3, Nihonbashi
1-chome, Chuo-ku, Tokyo 103-0027, Japan

OMURW706C2E201102A
PRINTED IN JAPAN



INTRODUCTION

Request to those who operate the crane

The operator's manual describes correct operation methods, simple inspection, and service for the UNIC crane.

Be sure to read this manual carefully to carry out correct and safe operation of the crane. Operate the crane after you have understood the contents of this manual.

Although we take all possible measures to ensure quality of the crane, you are requested to contact our business offices, UNIC sales agents, or authorized service stations whenever you have anything you do not understand.

◆ **For making inquiries**

When making inquiries, ordering spare parts, and requesting repairs, be sure to inform us of the crane model, specification, serial number, and date of manufacture which are indicated on the name plate.

◆ **Name plate** of the machine is located at the side of column.

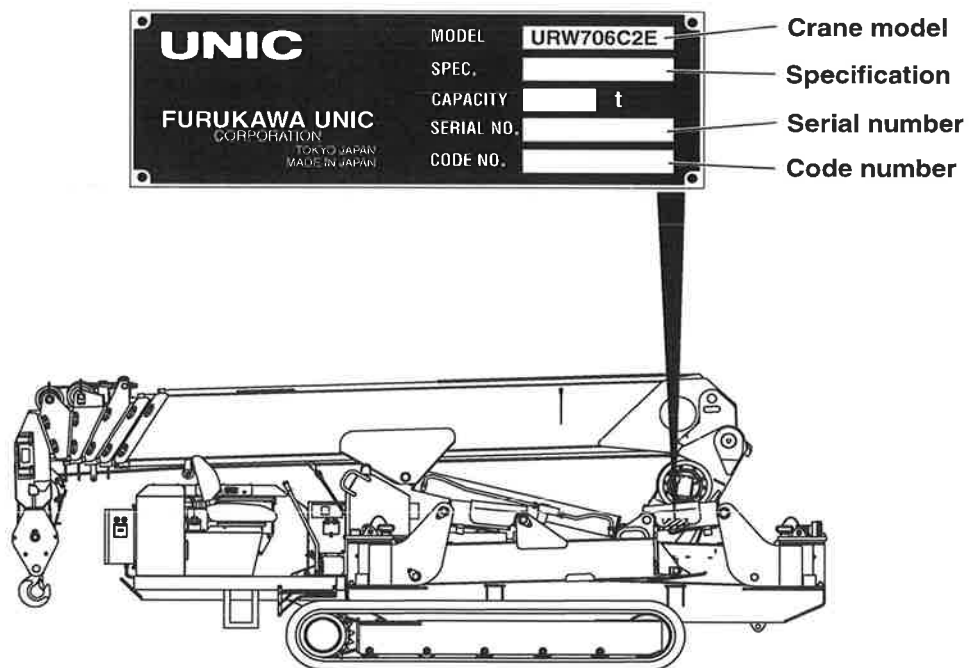



TABLE OF CONTENTS

SETUP OF THIS MANUAL0- 4

1. FOR SAFETY OPERATION

- 1 Request to customers1- 1

2. SAFETY PRECAUTIONS ON CARRIER OPERATION

- 1 Before operation2- 1
2 During operation2- 2
3 When loading and unloading2- 3
4 After operation2- 4

3. SAFETY PRECAUTIONS ON CRANE OPERATION

- 1 Before operation3- 1
2 During operation3- 2
3 After operation3- 4

4. DESCRIPTION OF CARRIER EQUIPMENT4- 1

5. DESCRIPTION OF CRANE EQUIPMENT5- 1

6. NAME PLATES

- 1 Description of name plates (Stickers)6- 1
2 Stickers in detail6- 2

7. DEFINITION OF TERMS

- 1 Outrigger extension7- 1
2 How boom-sections are extended7- 3
3 Net rated load7- 4
4 Rated load7- 4
5 Lifting capacity7- 4
6 Working radius7- 4
7 Boom length7- 4
8 Boom angle7- 4
9 Lift above ground7- 4

8.HOW TO REFER TO WORKING RANGE CHART AND RATED LOAD CHART

- 1 Working range chart.....8- 1
2 Net rated load chart8- 2

9.DESCRPTION OF EACH CONTROL DEVICE

- 1 Overwinding alarm9- 1
2 Automatic stop for overwinding9- 2
3 Load indicator (With angle meter)9- 4
4 Warning horn9- 7
5 Retaining mechanism for slinging wire rope9- 7
6 Automatic stop for leaving minimum wire rope (With wire rope retaining roller)9- 7

10. HOW TO OPERATE CARRIER

- 1 Designation of each control lever and its location ..10- 1
2 Preparation before operation10- 2
3 How to operate10- 5
4 How to crawl10- 8
5 How to fasten carrier when in transportation10-14

11. HOW TO OPERATE CRANE

- 1 Designation of each control lever and its location11- 1
2 Preparation before operation11- 2
3 Inspection before starting crane operation ..11- 3
4 Procedures to set up outriggers11- 5
5 How to operate boom for derricking 11-10
6 How to hoist and lower the hook11-11
7 How to telescope boom11-13
8 How to slew boom11-15
9 How to use extension jib (option)11-17
10 How to use searcher hook (option)11-22
11 How to store crane11-25
12 Procedures for storing hook11-26
13 How to store outriggers11-28



TABLE OF CONTENTS

12. U-WAVE, RADIO REMOTE CONTROL DEVICE

- 1 Request to those who operate the crane .12- 1
- 2 Safety precautions12- 2
- 3 Designation of each equipment12- 5
- 4 Inspection before crane operation12- 8
- 5 How to switch crane operation mode12-10
- 6 How to operate the crane through radio control operation12-12
- 7 How to replace batteries of transmitter ..12-34
- 8 Daily checks, trouble inspection12-37

13. MAINTENANCE AND INSPECTION OF CARRIER

- 1 Inspection before operation13- 2
- 2 Inspection and Maintenance which is to be carried out every 250 hours or 3 months13-13
- 3 Inspection and Maintenance which is to be carried out every 500 hours or 6 months13-22
- 4 Inspection and Maintenance which is to be carried out every 1000 hours or 12 months .13-24
- 5 Non-regular maintenance13-30
- 6 Storage13-36
- 7 Fitting safety covers13-37
- 8 Maintenance and inspection of engine ...13-37

14. MAINTENANCE AND INSPECTION OF CRANE

- 1 Inspection before operation14- 2
- 2 Cleaning14- 3
- 3 Inspection of bolts mounting slewing bearings14- 3
- 4 Replacement of wire rope14- 4
- 5 Replacement of expendable parts14- 7

15. WATER SUPPLY AND LUBRICATION TO CARRIER

- 1 Precaution when carrying out filling water and lubrication15- 1
- 2 List of recommended lubricant15- 2
- 3 Filling water and lubrication chart.....15- 4

16. LUBRICATION TO CRANE

- 1 Precaution when carrying out lubrication16- 1
- 2 List of recommended lubricant16- 2
- 3 Lubrication chart.....16- 3
- 4 Lubrication.....16- 4

17. MAJOR SPECIFICATIONS

- 1 URW706CDE (6-section boom)17- 1
- 2 Major specification (Radio remote control device)...17- 7

18. MODE INDICATOR LAMP (CONTROL BOX)

- 1 Mode indicator lamp (Control box)18- 1

19. MEASURES TO BE TAKEN IN AN EMERGENCY.....19- 1



SETUP OF THIS MANUAL

SETUP OF THIS MANUAL

Crane covered in this manual have some difference in operation in accordance with the specifications of with or without radio remote controller.

Difference in operation due to crane specifications is separately illustrated in this manual for each specification.

1. Designation of specification

Crane covered in this manual are roughly divided into three, the radio remote control type, the cable remote control type and the manual control type.

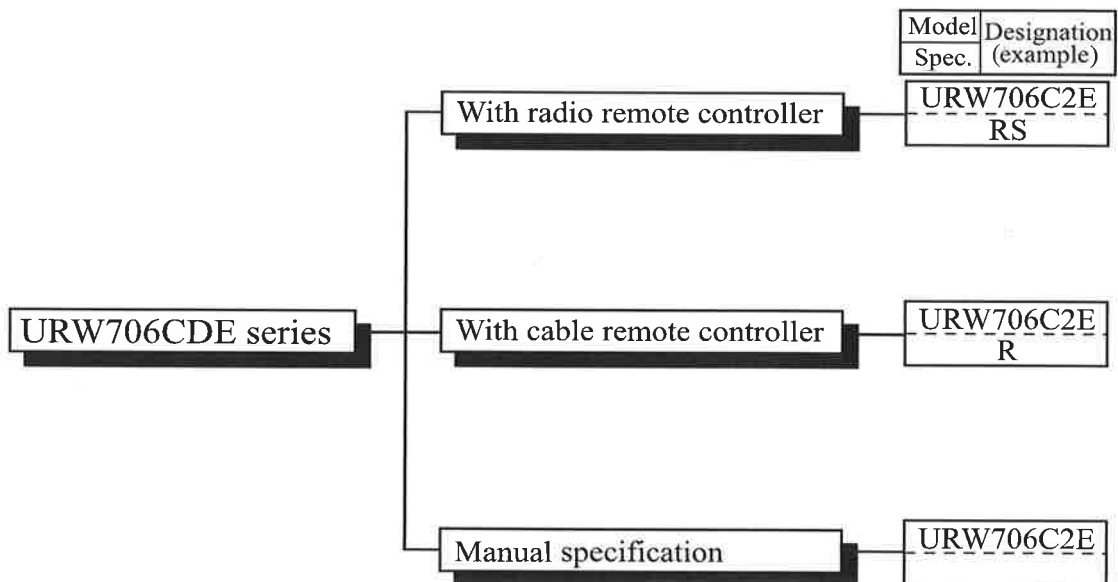



1. FOR SAFETY OPERATION

Observe all the safety regulations !



★ Read preventive measures against danger and cautions stated in this manual for proper understanding.

★ Most accidents related to the crane occur due to operation, maintenance, and inspection which have failed in observing basic safety regulations.

1 Request to customers

◆ Never failed to observe **⚠ WARNING** and **⚠ CAUTION** described in the manual as they are of great importance in safety and the crane operation.

⚠ WARNING . Failure to observe this may invite an accident resulting in injury or death.

⚠ CAUTION . Failure to observe this may cause damage to the crane.

◆ Store this operator's manual where it is easily accessible to read it over and over again.

◆ Failure to observe the right operation and maintenance/inspection illustrated in this manual may cause trouble in the crane and may invite an accident, and this will not only shorten its service life but will impair safety in the crane operation.

Please remember, in such cases, that no warranty will be given even if the crane is within valid warranty period.

◆ In order to prevent injury or death to crane operators and to those who stand close to crane operating area due to operational mistake, caution plates are stuck on the crane. You are requested to read them carefully.

◆ Do not alter the crane.

★ If you want to make an alteration, contact with UNIC sales agent or an authorized service shop.

★ UNIC does not bear any responsibility for troubles and /or accidents due to unauthorized alteration.

2. SAFETY PRECAUTIONS ON CARRIER OPERATION

! WARNING

★Observe the cautions for securing safety. Failure to observe the cautions may invite trouble or serious accident.

1 Before operation

1 Dress neatly and wear protectors such as helmet, safety shoes, and gloves without fail.

★Do not wear baggy clothes and accessories which can be caught by control levers and fittings, and oil-stained working clothes which may catch fire.

2 Be sure to make inspection before operation and periodical voluntary inspection. If found something wrong, repair it immediately.

3 The crane is prohibited to crawl on a public road by the road traffic law.

4 Check that no safety covers have been left removed.

★It is very dangerous to start the engine, to operate the crane with the safety cover removed as the driving mechanism is exposed.

5 Be sure to stop the engine before refueling or supplying and changing lubricant. A fire source such as smoking cigarette in mouth is strictly prohibited. Failure to observe this may cause a fire.

6 When starting the engine in a small limited area or indoors, open the windows and doors for well ventilation.

★Poor ventilation may invite an exhaust gas poisoning.

7 Release the interlock for crane-crawl operation by pressing the pedal when crawling the crane.

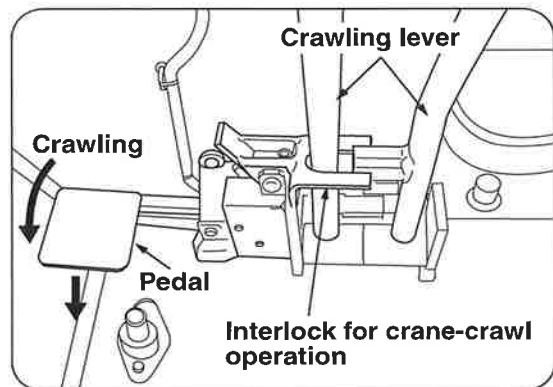

★Crane will not work by controlling crane operation levers with releasing the interlock for crane-crawl operation.



MEMO

A series of horizontal lines for writing, starting with a dashed line and followed by solid lines.



SAFETY PRECAUTIONS ON CARRIER OPERATION

2 *During operation*

1 The machine employs particularly small truck to facilitate working in a restricted space.

Since high performance crane is mounted on the small truck, it has been built with a higher center of gravity.

★Take special care not to overturn the crane when crawling on a unlevelled ground.

2 When crawling the crane, be sure to put outriggers in a condition of being stored and store the hook.

3 Do not run the crane with a cargo hoisted or without the crane being stored.

4 Special care must be taken to run the crane slowly when making a quick turn and crawling on a rough road.

5 When running over a bump, be sure to slow down the crane and direct it straight to the bump to avoid unnecessary shock to the crane body.

6 Be sure to use a foot-board to run over a ramp of more than 15cm.

7 Crawl the crane with low (1st) speed gear on a slope.

8 Be sure to use a pallet against the rubber crawler when parking the crane on a slope.

9 Do not make an abrupt stop and start, and change a course on a slope.

10 When crawling up and down a slope, operate the crane by standing at a higher position than the crane body.

11 Do not use the crane on a steep slope of more than 10 degrees.

Pay attention that the crane will not lean by more than 10 degrees due to jolting when operating/crawling on a unlevelled road.

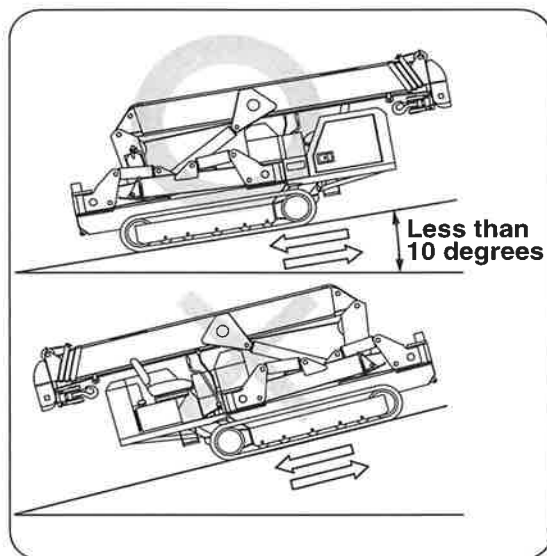

12 Do not run the crane over bumpy area, lying rocks with sharp edges, rough solid rock, small broken stones, edges of steel plate, steel bars for reinforcement, scrap metals, and waste materials and on a road such as in riverside where covered with many stones which may remarkably shorten service life of rubber crawler.

13 Do not take an article or an animal in the crane.

★It may invite critical situation due to abrupt swing or shift of center of gravity.

14 Do not park the crane over a place where withered grass or straw are being spread.

★It may cause a fire by heat of exhaust pipe or exhaust gas.



SAFETY PRECAUTIONS ON CARRIER OPERATION

15 Do not use the hook holder mounted in the rear side of the crane body as a means of pulling a vehicle. This may break the holder.

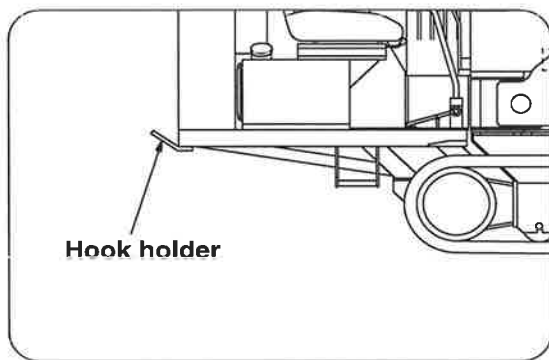

16 To avoid rubber crawler damage.

| | | |
|--|-----|---|
| | (O) | Be sure to drive both sides of crawler in the same direction for making a turn. |
| | (X) | Do not drive both sides of crawler in the opposite direction each other. |
| | (X) | Do not drive only one side of the crawler. |

★For the white (or gray) crawler, observe the driving strictly in terms of its characteristics.

3 When loading and unloading

1 When loading and unloading the crane, use a non-slip foot-board with a enough capacity of strength, width, and length and run the crane straight up and down at a very low speed.

Changing direction of the crane on the foot-board may cause the crane to fall off.

2 Stop the engine, apply parking brake, and put drags to wheels to secure the mounting vehicle when loading and unloading the crane.

★Failure to observe this may cause the crane to fall off because the vehicle shift while it is being loaded and unloaded.

★Work by following the instructions illustrated in the sticker, "Loading and unloading procedures". (Refer to page 6-5.)



SAFETY PRECAUTIONS ON CARRIER OPERATION

4 After operation

- 1** Return the crawling lever and run the engine at a low speed.
- 2** Take your foot off the pedal to lock crawling levers.
- 3** Stop the engine and remove dirt and dust stuck on the crane body.
★ Since dust stuck on the battery, electric wiring, and engine related components such as muffler may cause a fire in particular, be sure to remove it.
- 4** Cover the crane or store it in a storage house to prevent it from being accessed by unrelated persons such as children.
★ Cover the crane after heated sections have been cooled off.
Putting a cover on while the crane body is still hot may cause a fire.
- 5** Remove the starter switch key to store.
- 6** Disconnect a battery cable before the crane is to be stored for a long period of time.
★ Failure to disconnect it may cause a fire as cables short-circuited by gnawing animals such as rat.

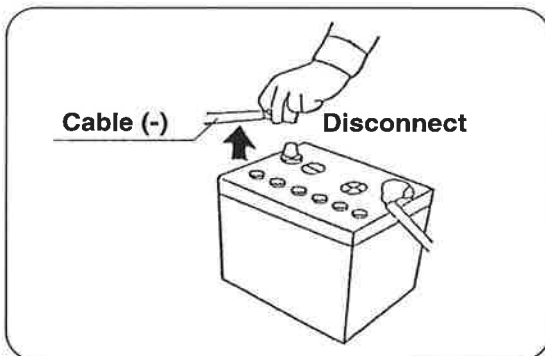



3. SAFETY PRECAUTIONS ON CRANE OPERATION

1 Before operation

1 Be sure to make inspection before operation and periodical inspection for slinging implements.

★If a defective slinging implement is used, fall of lifted cargo may result.

2 Make sure crawling levers are locked.

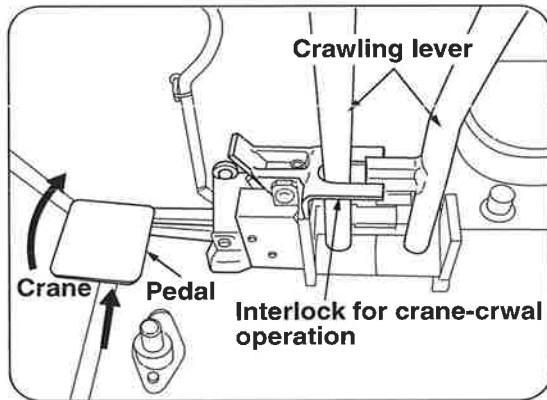

3 Turn ON the overwinding alarm switch.

4 Make sure that each safety device is always functioning properly.

★Be sure to turn ON the overwinding alarm switch before starting crane operation.

5 Keep a safety distance away from the high-voltage power line to avoid an electric shock.

★The crane is not electrically insulated.

★When the crane is operated near the power transmission line or the power distribution line, there may be a risk of electric shock due to electric discharge even if a part of the crane such as boom will not make a direct contact with the power lines.

★When the crane is to be operated close to the power transmission or distribution line, contact in advance with a local power company to make arrangements concerning safety for starting the crane operation.

★If crane operation close to the power transmission or distribution line is unavoidable, be sure to secure safety distance from the power lines.

List of target safety distance

Power transmission line

| Voltage | Safety distance (target) |
|---------------|--------------------------|
| 500,000 volts | 11.0m or more |
| 275,000 volts | 7.0m or more |
| 187,000 volts | 6.0m or more |
| 154,000 volts | 5.0m or more |
| 66,000 volts | 4.0m or more |
| 22,000 volts | 3.0m or more |

Power distribution line

| Voltage | Safety distance (target) |
|-------------|--------------------------|
| 6,600 volts | 2.0m or more |

6 Do not operate the crane when wind velocity exceeds 10m/sec. and/or while thundering.

★Crane operation while strong wind is blowing can cause fall of a lifted cargo or overturn of the crane as the boom and/or a lifted cargo are hit by a gust of wind.

7 Pay attention that anyone except persons concerned will not enter within a working radius of the crane.

★Take good care to carry out safety operation by keeping a close watch around the working area.



SAFETY PRECAUTIONS ON CRANE OPERATION

8 Make sure that the ground on which outriggers are to be set up is solid and firm.

★When setting up the outriggers on an unlevelled ground or on a slope, be sure to place a support (such as plank, steel plate etc.) under the outrigger foot flanges to keep the crane level.

In addition, when the crane is to be operated on a soft ground, take the same measures to prevent the outrigger foot flanges from sinking into the ground when a cargo is lifted up.

9 Lift up the crawler by approx. 50mm from the ground.



10 Operation with the crane kept leaning makes it unstable when a cargo is lifted up.

Such operation can cause the crane to be overturned.

11 In normal crane operation, be sure to set up the crane level with the outriggers fully extended.

12 Do not stand under or in front of the hook when unhooking as it swings.

13 Do not try adjusting hydraulic equipment.

2 During operation

1 Pay attention that the hook will not be overwound.

Be sure to turn ON the "overwinding alarm switch".

★Remember that the hook is wound up when boom is extending.

★If the hook hits against the boom top due to overwinding of the hook, it may cause damage to wire rope and the sheaves at the boom top and may cause the fall of lifted cargo.

2 Operate each lever slowly and smoothly.

★An abrupt lever operation with a cargo lifted gives an excessive shock to the crane which may cause damage or overturn to the crane.

★If a control lever will not make a smooth return to its neutral position, carry out lubrication and repair as soon as possible.

3 Slew the crane at low speed.

★Swing of a lifted cargo increases working radius of the crane which may cause it to be overloaded.

4 If the engine speed is too slow when operating the crane, press the accelerator to increase it.

★Crane operation with the engine (and pump) running at low speed may cause a cargo hoisted up to swing due to pulsation of the engine.

This is not a malfunction but impairs smooth control of the crane.



SAFETY PRECAUTIONS ON CRANE OPERATION

5 Overloaded operation is strictly prohibited.

★Crane operation with a load exceeding the rated load hoisted may cause damage or overturn to the crane.

6 Pulling a cargo sideways, straight, or obliquely is strictly prohibited.

★These operation may cause slewing members, booms, columns, and derrick cylinder to be damaged.

7 When a cargo to be lifted is detached from the ground, stop lifting it up temporarily to confirm safety.

★When a cargo to be lifted is detached from the ground, stop lifting it up temporarily to make sure that the cargo is kept horizontally, the crane maintains its stability, and the rope slinging up the cargo is positioned properly. Then lift it up again after making sure of the safety.

★For lowering a cargo, stop lowering it immediately before it touches the ground then lower it again gradually.

8 Do not leave from operating position with a cargo hoisted.

★Lower a hoisted cargo onto the ground before leaving from the operation site.

9 Do not get up on a cargo being hoisted.

★This may cause a fall from the cargo being hoisted.

10 Do not stay under a hoisted cargo.

11 Pay attention that wire ropes will not be paid out unnecessarily to prevent ropes from being wound around the drum irregularly.

★Operation such as paying out wire ropes further with a cargo placed on the ground, retraction and/or lowering boom loosen the ropes to cause them irregular winding which results in remarkable shortening service life of the ropes.

★Wind the first layer of rope firmly and regularly around the drum.

★Correct kinks of rope immediately with a mallet.

12 Pay extra attention to underground crane work in which the hook must be lowered further than the work on the ground.

★When paying out wire ropes, be sure that more than 3 turns of rope must always be left on the drum.

13 Stop crane operation when temperature of hydraulic oil exceeds 80°C.

★Oil temperature is apt to rise easily if repeated operation of winding up and down the hook, especially in a high lift, is required.

★Excessive high temperature of hydraulic oil damages high-pressure hoses and gaskets being employed to cause the oil to spout out so that a scald may result.



SAFETY PRECAUTIONS ON CRANE OPERATION

3 ***After operation***

1 Make sure that the booms, the outriggers, and the hook have been stored before crawling the crane.

2 Do not carry out maintenance and inspection while temperature of either hydraulic oil or gear oil is still high.

★ Temperature of both hydraulic and gear oil is high immediately after crane operation so that accumulated high pressure still remains. Removing filling cap, draining oil, or replacing oil filter while temperature is still high allows hydraulic and/or gear oil to spout out and a scald may result.

4. DESCRIPTION OF CARRIER EQUIPMENT

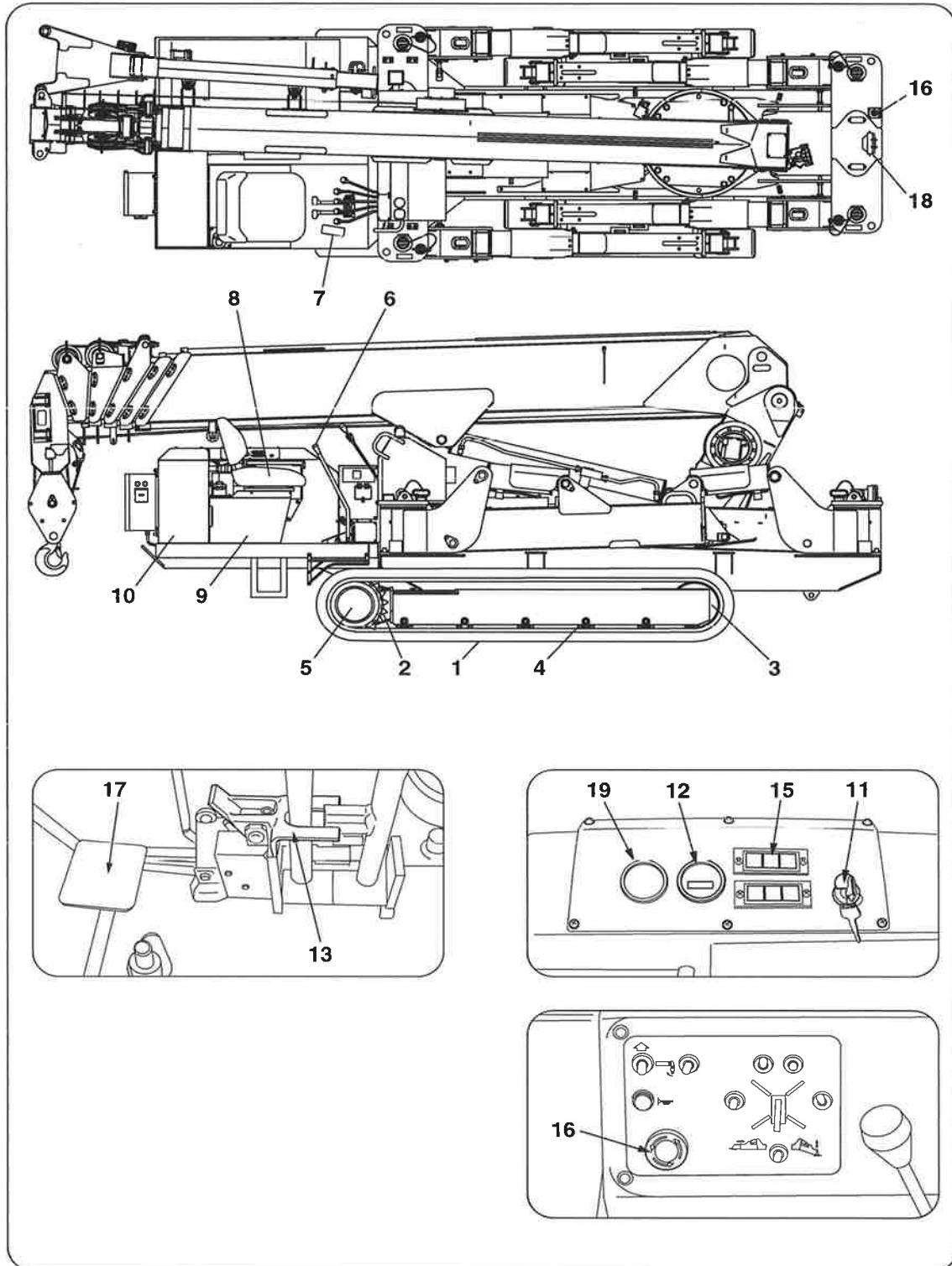



DESCRIPTION OF CARRIER EQUIPMENT

1. Rubber crawler

Cored bar and steel fabric(cords) are integrally molded in the rubber which is of the same quality as automobile tire.

2. Wheel sprocket

It transmits driving power to the rubber crawler to allow the crane to crawl.

3. Idle roller

This is a roller which gives a proper tension to the rubber crawler.

4. Truck roller

This supports the weight of crane and rolls on the rubber crawler.

5. Crawling motor

Hydraulic motor with reduction gears which transmits driving power to the wheel sprocket is built inside.

6. Crawling lever

This is to change crawling speed and direction.

7. Accelerator pedal

This is to control engine speed.

8. Driver's seat

This is a seat on which operator sits to operate the crane.

9. Fuel tank

This is filled with diesel oil.

10. Hydraulic oil tank

This is filled with hydraulic oil which is commonly supplied both to the carrier and to the crane.

11. Starter switch

This is a switch to start and stop the engine.

12. Hour meter

This indicates total engine running time.

13. Interlock for crane-crawl operation

This allows the crawling levers to lock while the crane is being operated and allows the crane not to be operated by the crane control levers when it is crawling. This can be switched by pressing "17 pedal".

14. Button for selecting crawling speed

This allows the crane to crawl faster while it is being depressed.

15. Warning lamp

The lamp lights to indicate that something is wrong with each section.

16. Emergency stop (engine) button

Depression of the switch allows the engine to stop and all the crane operation including traveling stop functioning.

17. Pedal

It is used to release crawling levers.

18. Head light

19. Fuel gauge

5. DESCRIPTION OF CRANE EQUIPMENT

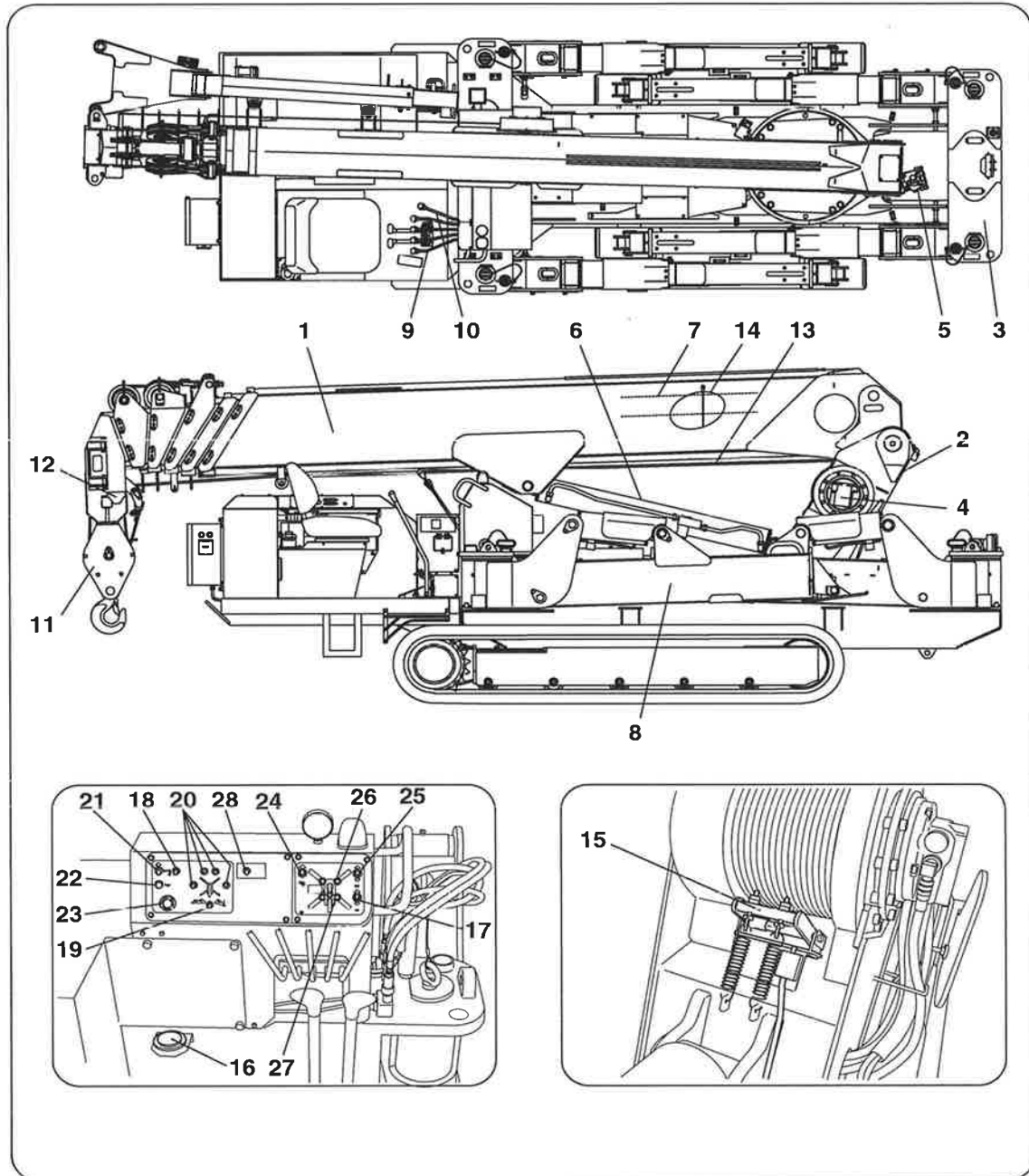



DESCRIPTION OF CRANE EQUIPMENT

1. Boom

It extends and retracts by hydraulic cylinder and the hook is suspended from its top.

2. Column

This is a vertically mounted member on the crane in which boom, winch, and derrick cylinders are installed.

The column can be turned by slewing device.

3. Frame

This is fixed on the vehicle to support the column and outriggers.

4. Hoist winch

This is a device which rotates the wire drum by hydraulic motor to hoist up and down a cargo via wire ropes.

5. Slewing device

This turns the column by hydraulic motor.

6. Derrick cylinder

This raises and lower the boom.

7. Telescoping cylinder

This extends and retracts sections of boom.

8. Outrigger

This supports the crane to maintain its stability while it is operated.

9. Crane operating levers

Respective levers control raising and lowering boom, hoisting a cargo up and down, telescoping boom, and slewing boom.

10. Outrigger control levers

Respective levers control raising/lowering and extending/retracting outriggers.

11. Hook

12. Overwinding alarm

When the hook comes close to the boom top, this makes an alarm to warn that wire ropes are to be overwound.

13. Wire rope

14. Load indicator

This reads the rated load value corresponding to extended length of the boom and its raised angle.

15. Automatic stop for leaving minimum wire rope (With wire rope retaining roller)

This is a device to restrict slackening of wire rope on the drum which allows to stop unwinding automatically when remaining wire ropes on the drum come close to 3 turns.

16. Level

This an instrument for checking horizontal plane of the crane body.

17. Voice switch

This switches ON and OFF the voice message.

18. Operation mode switch

This selects crane operation mode and outrigger operation mode.

19. Outrigger vertical/horizontal selector switch

This switches extension/retraction control of vertical cylinder for outriggers and of inner boxes.

20. Outrigger control switch

This selects extension/retraction of each outrigger of four (4).

Simultaneous extension and retraction of outriggers can be impossible.

21. Hook storing switch

Turning the switch to the storing position allows the hook to be stored.

22. Horn switch

Depression of the switch allows the alarm horn to sound.



DESCRIPTION OF CRANE EQUIPMENT

23. Emergency stop (engine) switch

Depression of the switch allows the engine to stop and all the crane operation including traveling stop functioning.

24. Automatic stop for over-winding reset switch

When the crane cannot to be operated due to a fault in function of automatic stop for over-winding, turning the switch to reset side releases the automatic stop for over-winding device.

25. Head light switch

Turning the switch ON allows the head light to light.

26. Boom storage monitor lamp

The monitor lamp lights when the boom has been stored.

Outriggers can be operated only when the monitor lamp lights.

27. Outrigger monitor lamp (extension)

When turning outriggers manually from their stored positions and set pins have fully been inserted, the lamp indicating extension of outrigger lights.

Outriggers cannot be operated unless all the four (4) pins have been inserted.

28. Mode selector switch

This switches between radio remote control mode and manual operation mode.



6. NAME PLATES

1 Description of name plates (Stickers)

The machine is provided with stickers indicating caution (framed in box) and specifications as shown in the figure below, and in addition to that there are stickers showing control levers, switches, and instructions for lubrication.

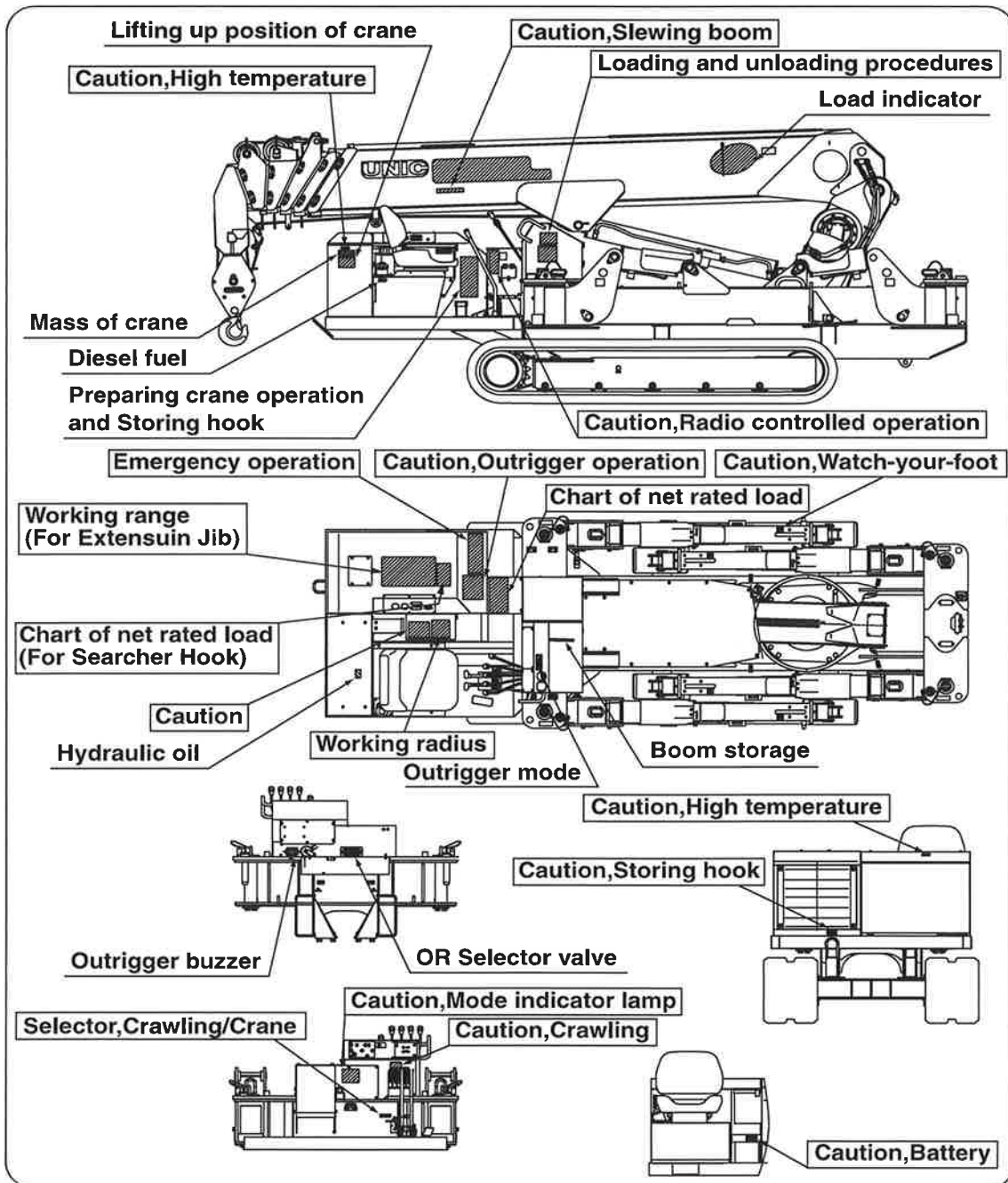



NAME PLATES

2 Stickers in detail



- ★ Always keep the stickers clean so that they can be read easily.
- ★ If any of the stickers has come off, stick it again or replace it with new sticker.
- ★ When ordering stickers, specify the part number shown at the bottom-right of the sticker concerned.

Sticker [HIGH TEMPERATURE]



Sticker [BATTERY]

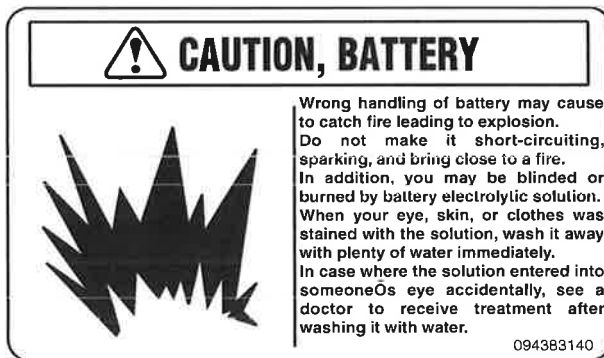

Sticker [WATCH-YOUR-FOOT]





NAME PLATES

Sticker [CAUTION]

CAUTION

- Carry out operation after you have read the instruction manual carefully.
- Confirm safety around the crane before starting operation
- Be sure to carry out inspection and maintenance before starting operation.
- Be sure to stop power (engine, power source) before inspection and maintenance.
- Carry out inspection and maintenance of engine after it has been cooled down.
- As the engine heats up, pay attention to prevent fire, always checking the surrounding area.
- Set up the crane flat and even by referring to a level.
- Load indicator reads the crane capacity when the crane has been set up on the level and solid ground. By referring to the reading of loadmeter, never try operating the crane overloaded.
- When lifting up a cargo exceeding the rated load, the crane may be in danger of overturn. Operate the crane by keeping to the rated load.
- Do not travel with a load lifted and operate the crane without outriggers extended which are very dangerous.
- Operate the crane with the outriggers extended and with the truck raised by approx. 50mm above the ground.
Operation without the truck raised may damage the truck and operation with truck raised too high is dangerous so that it is strictly prohibited.
- Keep an appropriate distance between the boom top and the hook while extending the booms.
- Simultaneous operation for extension and retraction of outriggers will not be possible.
- Store the hook securely before traveling.
- Be sure to turn OFF the key switch after crane operation has been completed.

B-524359

Sticker [CAUTION, CRAWLING]

CAUTION, TRAVELING UNIC

The truck might fall off or fall down during traveling.
Slow down the vehicle and direct your mind to traveling when passing close to road shoulder or on the soft ground.

094383160

NAME PLATES

Sticker [Emergency operation]

⚠️ OUTRIGGERS OPERATION FOR EMERGENCY

If outriggers will not function through normal operation, operate them temporarily by taking following steps.
After completion of the procedures, ask a nearby local UNIC authorized service shop for inspection and repair as soon as possible.

1. Remove covers at 2 places as illustrated in the figure 1.
2. Push the mode selection switch to switch it to the manual mode.
3. Return the boom to its storing position.
(Light the boom storage lamp on the outrigger monitor.)
4. Determine extension or retraction of the outrigger by the outrigger valve concerned.
Refer to table 1 and figure 2.
5. Turn the valve button by 90° with the button pushed down to lock it.
6. Determine the cylinder for actuating vertical or horizontal member of the outrigger by selecting outrigger control valve for operating vertical or horizontal member.
Push the solenoid valve button with a thin bar such as of screwdriver.
7. Operate the control lever of outrigger with the solenoid valve button depressed.

Remove covers with the sticker indicated by arrow marks.

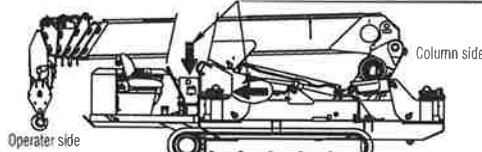

Fig.1 Covers to be removed

| Actuating direction of outrigger | Operation |
|----------------------------------|---|
| Extend | Turn it by 90° with "B" depressed to lock |
| Retract | Turn it by 90° with "A" depressed to lock |

(Note) Turn it back by 90° for unlocking the button.

Turn it by 90° with button depressed to lock Turn it by 90° with button depressed to lock

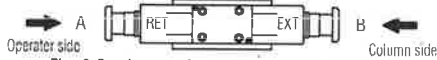

Fig. 2 Outrigger valve for extension & retraction

Table 2 How to operate outrigger valves for operating vertical or horizontal members

| Outrigger to be operated | Operation |
|--------------------------|---|
| Outrigger ① | Vertical Control lever with "1" depressed |
| | Horizontal Control lever with "2" depressed |
| Outrigger ② | Vertical Control lever with "5" depressed |
| | Horizontal Control lever with "6" depressed |
| Outrigger ③ | Vertical Control lever with "7" depressed |
| | Horizontal Control lever with "8" depressed |
| Outrigger ④ | Vertical Control lever with "3" depressed |
| | Horizontal Control lever with "4" depressed |

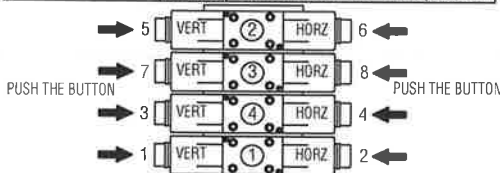

Fig.3 Outrigger valves for operating vertical members

(Note) When removing covers or depressing solenoid valve switches, work by paying attention not to injure wiring.

09KK81081-W706CDE

NAME PLATES

Sticker [Working radius]

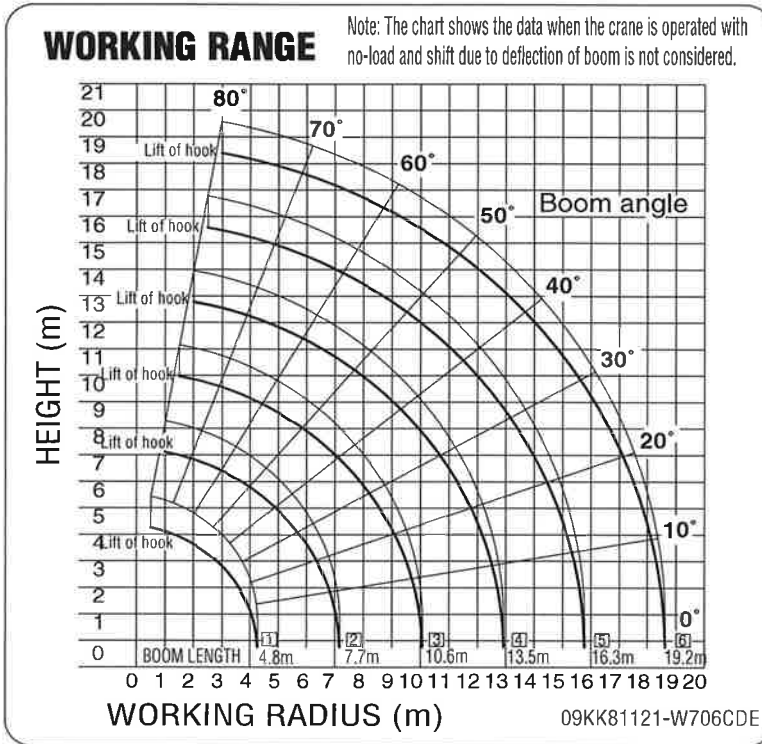

Sticker [Working range (For Extension Jib)]

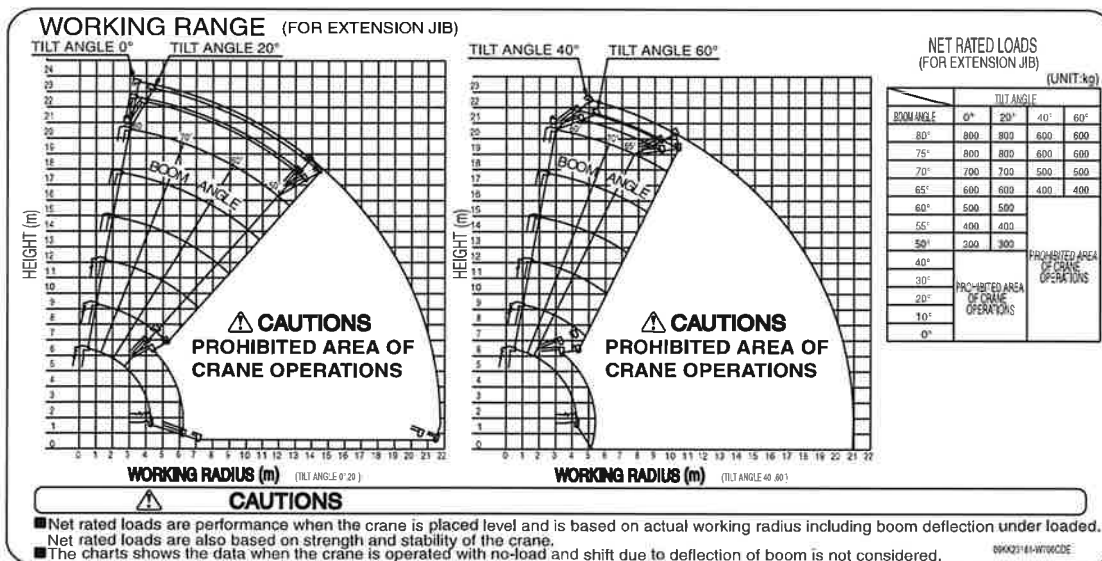

7. DEFINITION OF TERMS

1 Outrigger extension

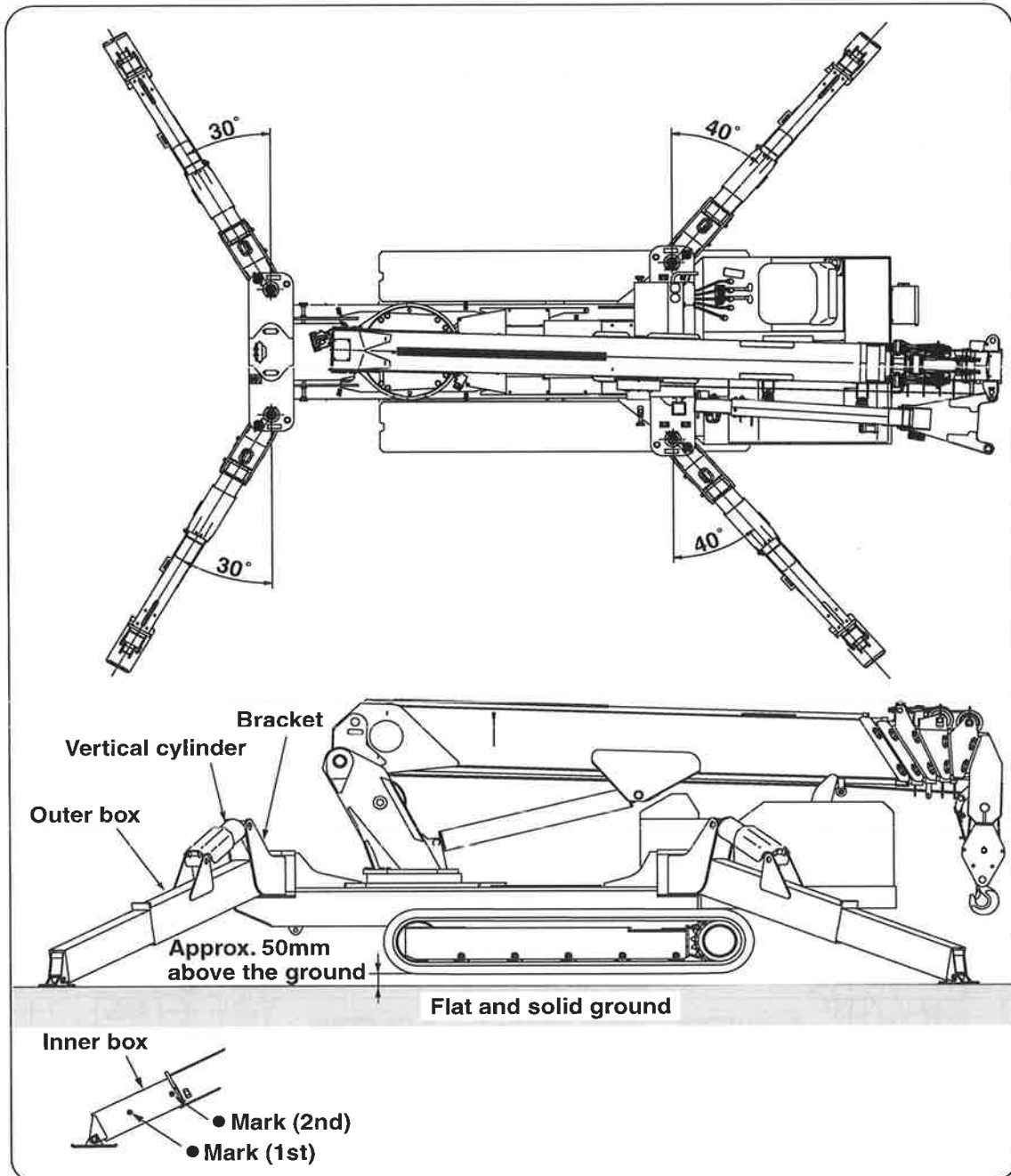

The figure above shows that outriggers are extended to their extremes. Carry out operation by making the crane level on a flat and solid ground with the outriggers extended to their extremes, and with the crane body raised by approx. 50mm above the ground.

DEFINITION OF TERMS

◆ Since the rated load varies according to how the outriggers are extended, the rated load has been set for respective extended conditions.

Figure below shows the cases where the outriggers are extended to “maximum”, “halfway”, and “minimum”.

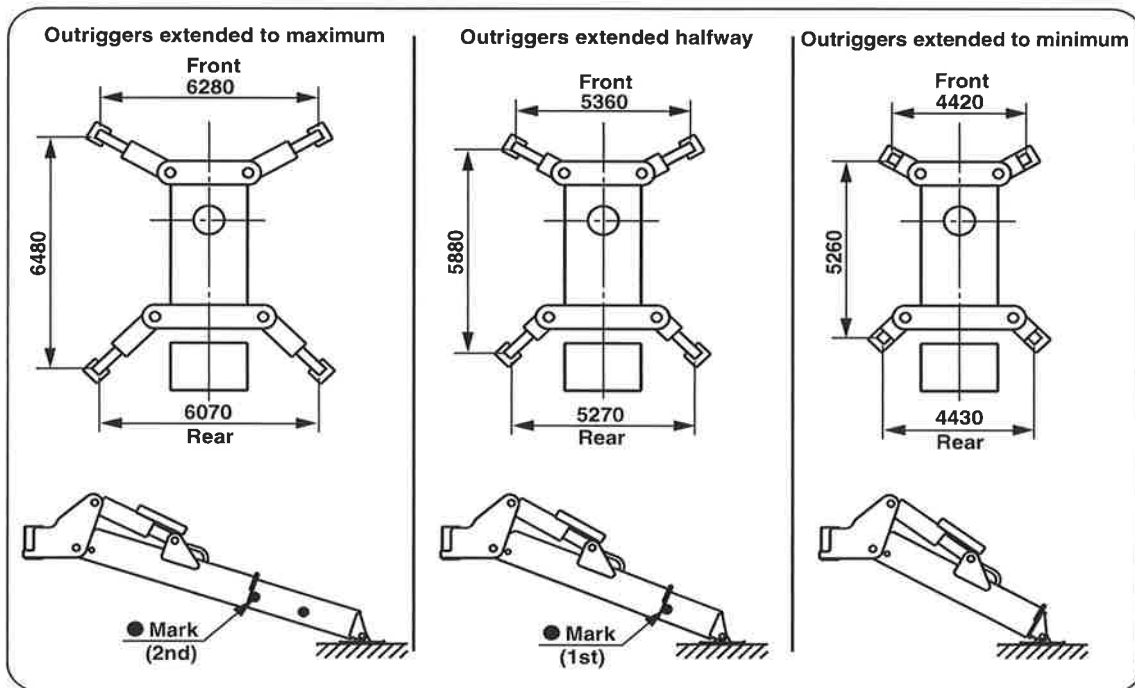

- ‘Outriggers extended to maximum’ means that the inner box is extended to a position where the 2nd ● mark is visible.
- ‘Outriggers extended to halfway’ means that the inner box is extended to a position where the 1st ● mark is visible.
- ‘Outriggers extended to minimum’ means that the inner box is extended to a position where the 1st ● mark is invisible.
- When each of 4(four) outriggers is set to different extension, operate the crane by using the worst extended capacity.

DEFINITION OF TERMS

2 How boom-sections are extended

6-section boom

● How boom-sections are extended

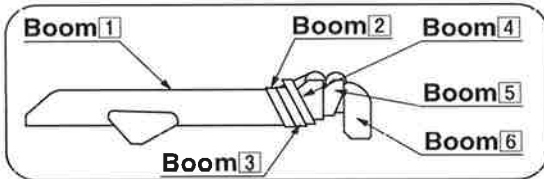

Boom : **1**

All boom sections are retracted.

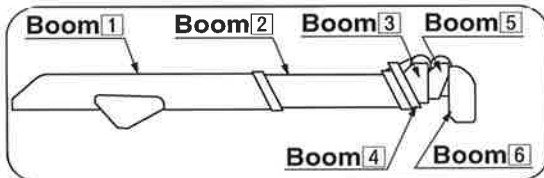

Boom : **1+2** or **2**

Boom section(2) only is extended.

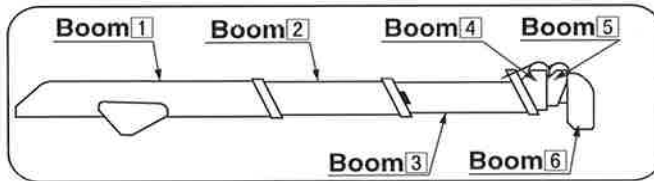

Boom : **1+2+3** or **3**

Boom sections(2) and (3) extended to a position where the mark **∧** on the boom section (3) is visible.

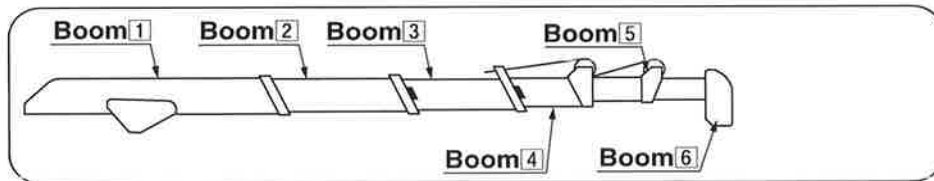

Boom : **1+2+3+4** or **4**

Boom sections are extended to a position where 1st mark **∧** on the boom section (4) is visible.

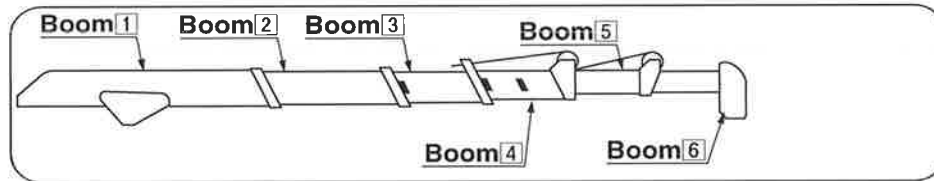

Boom : **1+2+3+4+5** or **5**

Boom sections are extended to a position where 2nd mark **∧** on the boom section (4) is visible.

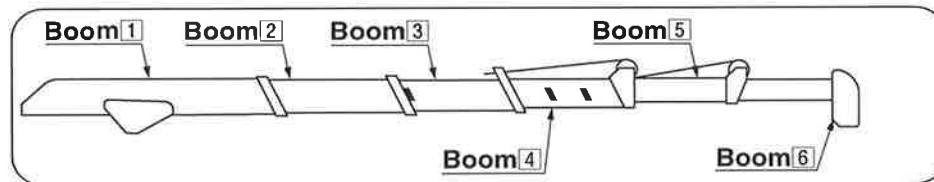

Boom : **1+2+3+4+5+6** or **6**

Boom sections(2), (3), (4), (5), and (6) are fully extended.

DEFINITION OF TERMS

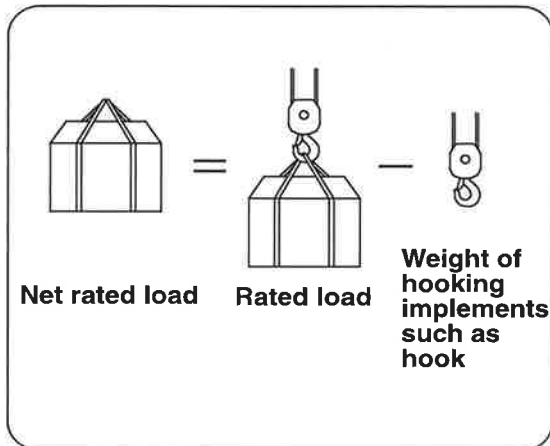

3 Net rated load

Net load which can be lifted by hook determined on the basis of stability of crane.

4 Rated load

Maximum load including hook and hooking implements which can be lifted according to the boom angle and/or the boom length determined on the basis of stability of crane.

5 Lifting capacity

This is the maximum of rated total load described at the item r above.

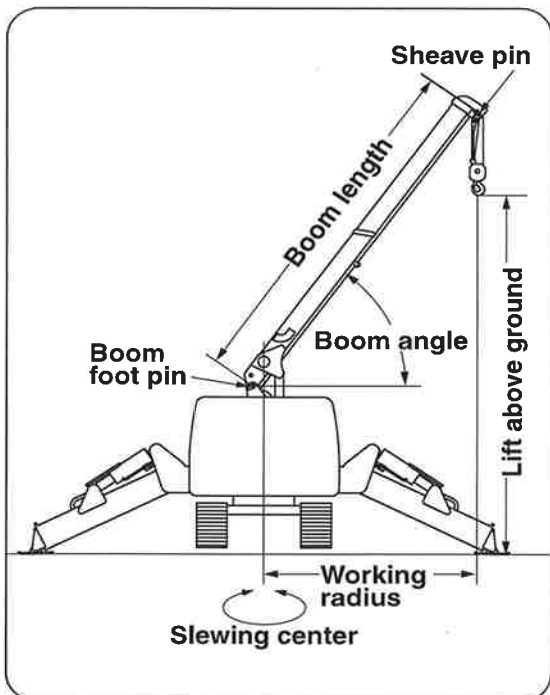

6 Working radius

This is horizontal distance from the slewing center to the hook center.

7 Boom length

This is distance from the boom foot pin to the sheave pin on the boom top.

8 Boom angle

This refers to an angle made by axis line of boom and the horizontal line.

9 Lift above ground

This refers to maximum vertical distance between bottom end of the hook to the ground surface with the hook wound up to touch the overwinding alarm detector.

8. HOW TO REFER TO WORKING RANGE CHART AND RATED LOAD CHART

These charts are stuck in front of crane operation levers and how to refer to charts is illustrated as follows:

1 Working range chart

The chart shows the relation among boom length and working radius, boom angle, and lift above ground.

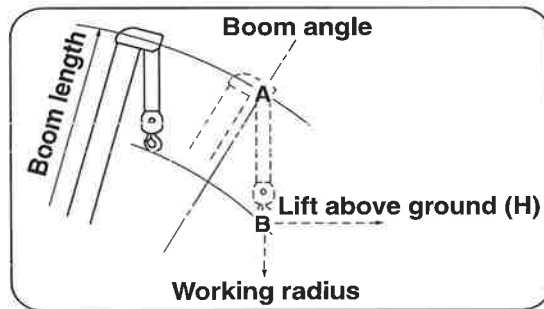
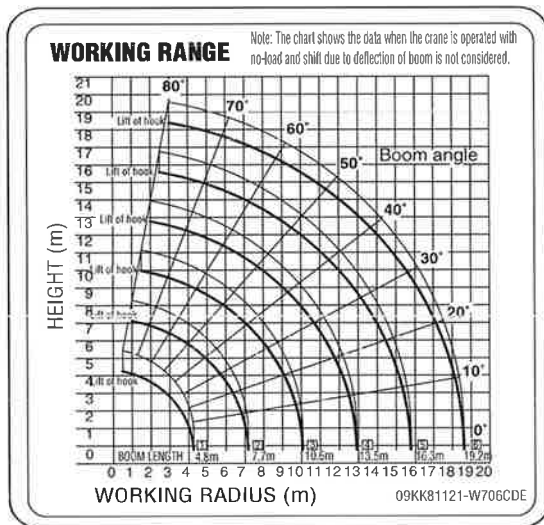

Although the point-A and the point-B follow the tracks along the same working radius, the point-A refers to the boom angle and the point-B the lift above ground.

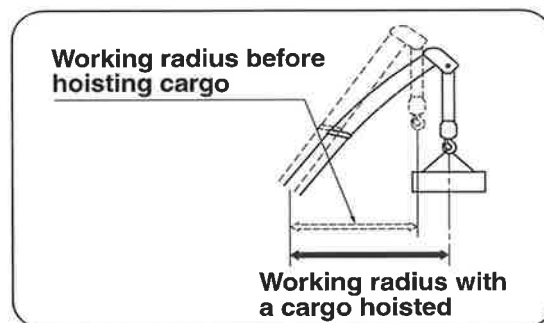

The working range chart does not incorporate any shift due to deflection of boom. Keep in mind that the actual working radius is somewhat extended due to boom deflection when a cargo is being hoisted.



HOW TO REFER TO WORKING RANGE CHART AND RATED LOAD CHART

2 Net rated load chart

The chart shows maximum load which can be hoisted up for every combination of boom-sections to be extended for each working radius.

Net rated loads chart

| BOOM SECTION 1 | | | |
|---------------------------------|------------------------|---------|--|
| WORKING RADIUS(m) | | | 2.7 3.0 3.5 4.0 4.3 |
| NET RATED LOAD(t) | OUTRIGGERS EXTENDED TO | MAXIMUM | 6.0 6.0 5.45 4.85 3.95 |
| | | HALFWAY | 6.0 6.0 5.45 4.85 3.95 |
| | | MINIMUM | 6.0 6.0 5.45 4.55 3.75 |
| BOOM SECTION 1+2 | | | |
| WORKING RADIUS(m) | | | 2.0 3.0 3.5 4.0 5.0 6.0 7.0 7.2 |
| NET RATED LOAD(t) | OUTRIGGERS EXTENDED TO | MAXIMUM | 6.0 6.0 5.35 4.75 3.75 2.95 2.25 2.0 |
| | | HALFWAY | 6.0 6.0 5.35 4.75 3.75 2.45 1.7 1.55 |
| | | MINIMUM | 6.0 6.0 5.35 4.65 2.55 1.65 1.15 1.05 |
| BOOM SECTION 1+2+3 | | | |
| WORKING RADIUS(m) | | | 2.7 4.0 5.0 6.0 7.0 8.0 9.0 10.0 10.1 |
| NET RATED LOAD(t) | OUTRIGGERS EXTENDED TO | MAXIMUM | 4.55 4.55 3.65 2.95 2.4 1.8 1.35 0.95 0.95 |
| | | HALFWAY | 4.55 4.55 3.65 2.55 1.75 1.3 0.95 0.7 0.7 |
| | | MINIMUM | 4.55 4.55 2.65 1.7 1.2 0.85 0.65 0.45 0.4 |
| BOOM SECTION 1+2+3+4 | | | |
| WORKING RADIUS(m) | | | 5.0 6.0 7.0 8.0 9.0 10.0 11.0 12.0 12.9 |
| NET RATED LOAD(t) | OUTRIGGERS EXTENDED TO | MAXIMUM | 2.95 2.55 2.15 1.85 1.5 1.2 0.95 0.8 0.45 |
| | | HALFWAY | 2.95 2.55 1.85 1.4 1.1 0.85 0.65 0.55 0.4 |
| | | MINIMUM | 2.75 1.85 1.3 1.0 0.75 0.55 0.43 0.33 0.24 |
| BOOM SECTION 1+2+3+4+5 | | | |
| WORKING RADIUS(m) | | | 6.0 8.0 9.0 10.0 11.0 12.0 13.0 14.0 15.0 15.8 |
| NET RATED LOAD(t) | OUTRIGGERS EXTENDED TO | MAXIMUM | 2.35 1.7 1.4 1.2 1.0 0.85 0.7 0.6 0.5 0.4 |
| | | HALFWAY | 2.35 1.5 1.15 0.95 0.75 0.6 0.5 0.4 0.3 0.25 |
| | | MINIMUM | 1.95 1.05 0.8 0.65 0.5 0.4 0.3 0.23 0.17 0.13 |
| BOOM SECTION 1+2+3+4+5+6 | | | |
| WORKING RADIUS(m) | | | 8.0 10.0 12.0 14.0 16.0 18.0 18.6 |
| NET RATED LOAD(t) | OUTRIGGERS EXTENDED TO | MAXIMUM | 1.35 1.0 0.8 0.6 0.4 0.25 0.2 |
| | | HALFWAY | 1.35 1.0 0.65 0.45 0.3 0.2 0.15 |
| | | MINIMUM | 1.1 0.7 0.45 0.28 0.17 0.09 0.06 |

⚠ CAUTION

★Net rated loads are performance when the crane is placed level and is based on an actual working radius including boom deflection under loaded.

★Net rated loads are also based on strength and stability of the crane.

★Pay attention that the net rated loads are changed according to how far the outriggers are extended.

9. DESCRIPTION OF EACH CONTROL DEVICE

1 Overwinding alarm

◆1. Function of overwinding alarm

The device automatically makes an alarm sound to warn that the wire ropes are being overwound when the hook comes close to the boom top.

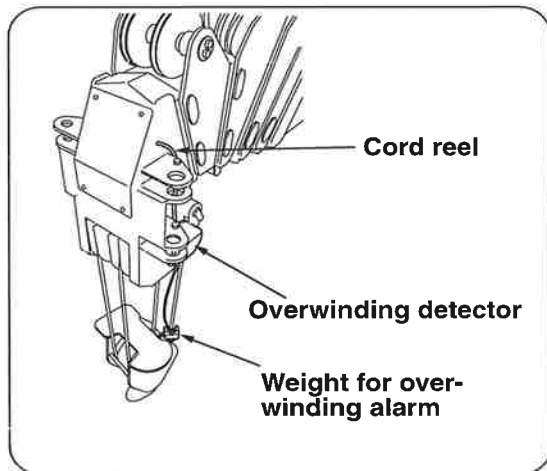

◆2. Operating procedures

1 Turn ON the voice switch before starting crane operation.

If the voice alarm sounds while the hook is being hoisted up or the boom is being extended, stop the crane operation immediately and lower the hook or retract the boom.

●Remarks

All the voice messages will not sound when the voice switch has been turned OFF.

In normal operation, turn ON the voice switch.

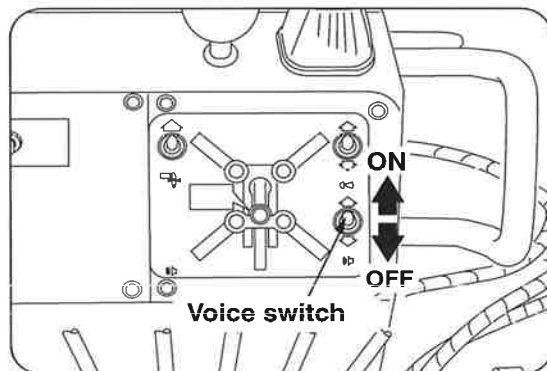

CAUTION

★When the voice switch is turned OFF, over-winding alarm will not function even if the hook has been over-wound.

Be sure to turn the voice switch ON before starting crane work and check that the voice alarm sounds every time when the weight for overwinding alarm is lifted up to the detector.

★Since the length of wire rope hanging the weight is specified by laws and regulations concerned, do not make it short at random.

★The alarm will sound even if any of electric wires connected to the over-winding detector at the boom top is broken. In this case, ask a UNIC service shop for repair.

DESCRIPTION OF EACH CONTROL DEVICE

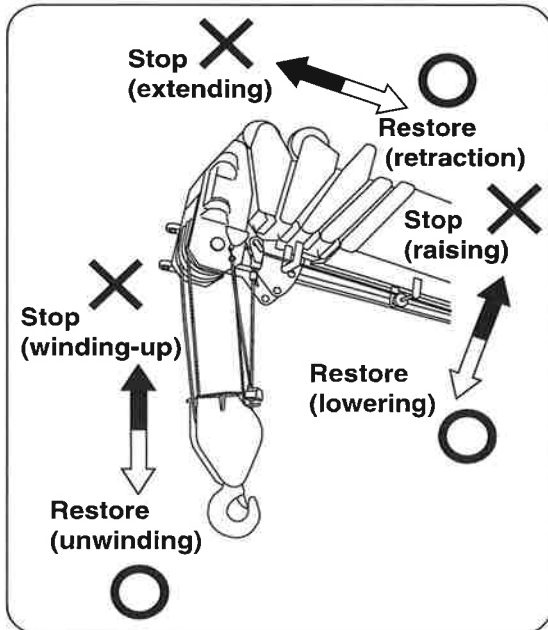

2 Automatic stop for overwinding

◆1. Function of automatic stop for overwinding

If the hook comes close to the boom top and it hits against the weight for over-winding alarm, voice alarm sounds and functions of winding-up hook, extending boom, and raising boom stop automatically.

When the automatic stop is activated, lower the hook, retract or lower the boom until the hook detaches from the weight for over-winding alarm.

This allows the activated automatic stop to return to be normal.

! CAUTION

★When resetting automatic stop by lowering boom, pay attention that the load will not exceed the rated load.

★Since viscosity of hydraulic oil increases during cold winter or in low temperature environment, when “winding-up hook” or “extending boom” is operated in high-speed, the crane may not be stopped immediately but with some delay even if the hook hits against the weight for over-winding alarm which is not a disorder. Operate the crane after temperature of hydraulic oil rises to a sufficient level by carrying out warming-up or operate it with a low speed while paying attention that the hook may not hit against the weight.

DESCRIPTION OF EACH CONTROL DEVICE

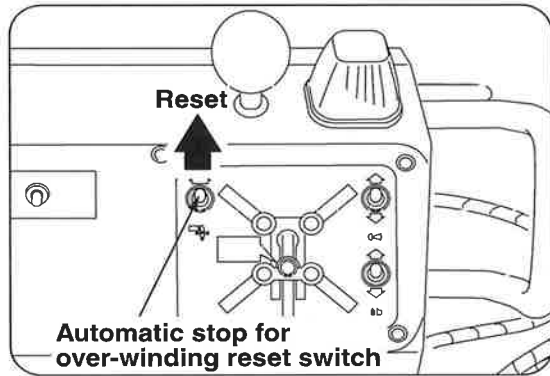

◆2. How to reset when automatic stop for over-winding is found to be out of order

If crane cannot be operated due to failure in the automatic stop, reset the automatic stop and store the crane.

●Step 1

Turn the reset switch for the automatic stop for over-winding to “Reset” and the automatic stop is to be reset.

Then wind up the hook, extend or raise the boom by controlling operation lever.

DESCRIPTION OF EACH CONTROL DEVICE

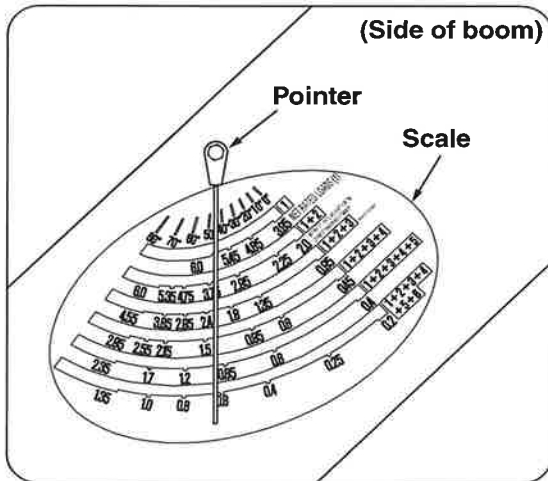

3 Load indicator (With angle meter)

The indicator reads the rated load corresponding to extended length of boom and its angle to show the maximum weight of cargo which can be hoisted at this point.

◆ 1. Rated load

The value to which the pointer on the scale of meter is the rated load in each combination of boom-sections being extended.

◆ 2. Boom angle

Pointer deflection on the angle scale reads the boom angle.

! CAUTION

★The load indicator reads the rated load when the outriggers are fully extended.

★The load indicator can not be used when the outriggers are extended to halfway or to minimum.

★Use a proper scale band according to boom-sections being extended.



DESCRIPTION OF EACH CONTROL DEVICE

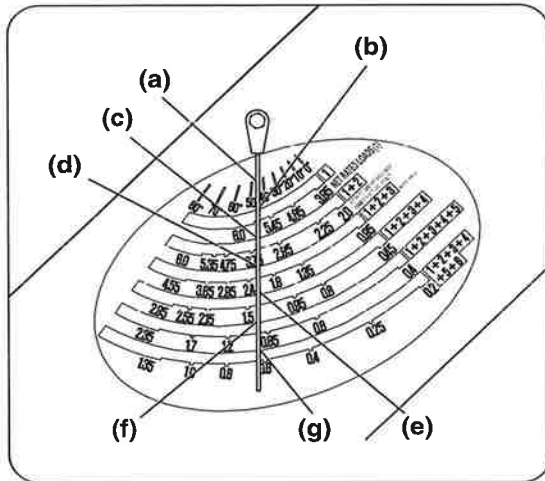

[Example]

How to read each valve when the pointer deflects as shown in the figure.

- (1) Boom angle reads 45° at the point (a) on the boom angle scale.
- (2) Maximum load which can be hoisted (rated load) reads:
 - For boom **1** (With all boom sections retracted) : 5.9t at point (b).
 - For boom **1+2** (With boom section **2** extended) : 3.7t at point (c).
 - For boom **1+2+3** (With boom-section **3** extended) : 2.3t at point (d).
 - For boom **1+2+3+4** (With boom-section **4** extended) : 1.3t at point (e).
 - For boom **1+2+3+4+5** (With boom-section **5** extended) : 0.95t at point (f).
 - For boom **1+2+3+4+5+6** (With boom-section **6** extended) : 0.65t at point (g).

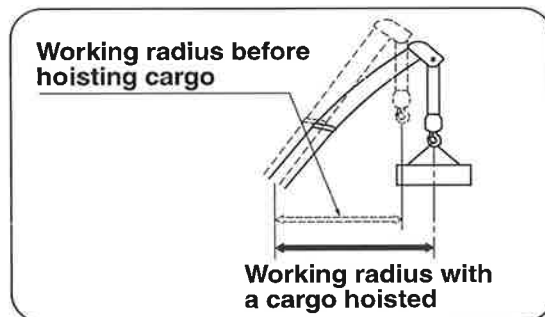

CAUTION

★ When a boom is extended to halfway, use the rated load with the boom concerned fully extended in order to secure safety.

- When boom-section **2** is extended from boom-section **1**, take the rated load for boom **1+2** (3.7t in the example shown above).
- When boom-section **3** is extended from boom-section **2**, take the rated load for boom **1+2+3** (2.3t in the example shown above).

★ Since the working radius increases due to deflection of the boom when a cargo starts to be lifted up, set the boom angle so that the hook comes to somewhat inner side.



DESCRIPTION OF EACH CONTROL DEVICE

◆ How to refer to hoisting capacity when outriggers are extended to minimum or to halfway.

As a general rule, the outriggers are to be extended to their extremes.

If it is forced to operate the crane with the outriggers extended to minimum or to halfway, operate the crane in accordance with instructions shown below.

1. Find the working radius.
2. The rated load is to be obtained from the data shown in the “outriggers extended to minimum on the chart of rated load” according to how boom-sections are extended.

- When operated with the outriggers extended to halfway, with the working radius of 7.0m, and with the boom configuration of **1+2+3**, take 1.75t.
- When operated with the outriggers extended to minimum, with the working radius of 7.0m, and with the boom configuration of **1+2+3**, take 1.2.

Net rated loads chart

| BOOM SECTION | | 1+2+3 | | | | | | | | | |
|-------------------|------------------------|---------|------|------|------|------|------|------|------|------|------|
| WORKING RADIUS(m) | | 2.7 | 4.0 | 5.0 | 6.0 | 7.0 | 8.0 | 9.0 | 10.0 | 10.1 | |
| NET RATED LOAD(t) | OUTRIGGERS EXTENDED TO | MAXIMUM | 4.55 | 4.55 | 3.65 | 2.95 | 2.4 | 1.8 | 1.35 | 0.95 | 0.95 |
| | | HALFWAY | 4.55 | 4.55 | 3.65 | 2.55 | 1.75 | 1.3 | 0.95 | 0.7 | 0.7 |
| | | MINIMUM | 4.55 | 4.55 | 2.65 | 1.7 | 1.2 | 0.85 | 0.65 | 0.45 | 0.4 |

| BOOM SECTION | | 1+2+3+4 | | | | | | | | | |
|-------------------|------------------------|---------|------|------|------|------|------|------|------|------|------|
| WORKING RADIUS(m) | | 5.0 | 6.0 | 7.0 | 8.0 | 9.0 | 10.0 | 11.0 | 12.0 | 12.9 | |
| NET RATED LOAD(t) | OUTRIGGERS EXTENDED TO | MAXIMUM | 2.95 | 2.55 | 2.15 | 1.85 | 1.5 | 1.2 | 0.95 | 0.8 | 0.45 |
| | | HALFWAY | 2.95 | 2.55 | 1.85 | 1.4 | 1.1 | 0.85 | 0.65 | 0.55 | 0.4 |
| | | MINIMUM | 2.75 | 1.85 | 1.3 | 1.0 | 0.75 | 0.55 | 0.43 | 0.33 | 0.24 |

CAUTION

★ When the outriggers are extended to minimum or to halfway, operate the crane according to capacity obtained from the “outriggers extended to minimum or to halfway accordingly on the chart of rated load”.

★ The load indicator can not be used when the outriggers are extended to minimum or to halfway.

DESCRIPTION OF EACH CONTROL DEVICE

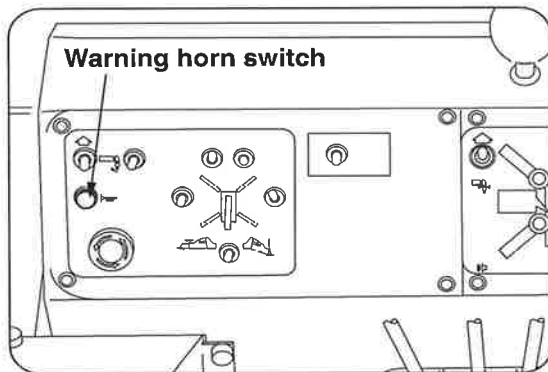

4 Warning horn

Before lifting up the cargo, depress the warning horn switch on the crawler panel to give warning sound to those who have entered within slewing range during crane operation, or to workers in charge of slinging work near the cargo or in a course where the cargo may pass along.

Depress the switch button to give warning sound.

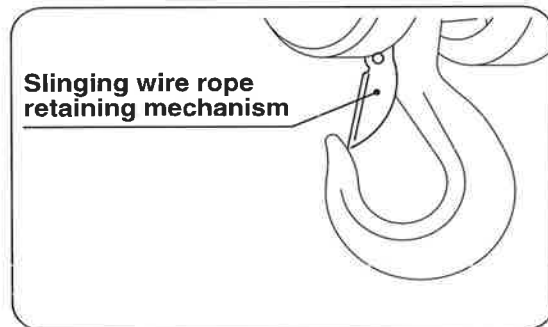

5 Retaining mechanism for slinging wire rope

The mechanism is to prevent slinging wire rope from being disengaged out of the hook.

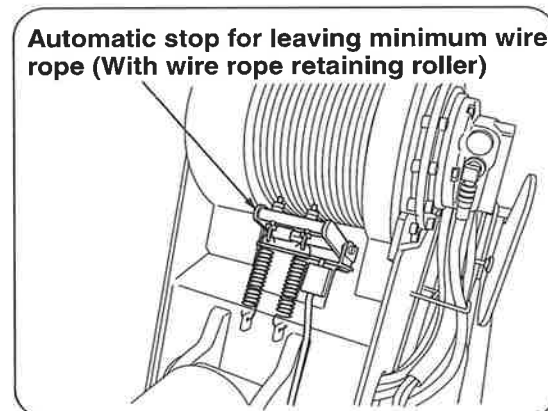

6 Automatic stop for leaving minimum wire rope (With wire rope retaining roller)

This is a device to restrict slackening of wire rope on the drum.

The device prevents the rope on the drum from slackening when winding up and down the hook or making it an abrupt stop and when the hook is lowered to the ground.

In addition, it allows to stop unwinding automatically when remaining wire ropes on the drum come close to 3 turns so that the rope can not be unwound further.

10. HOW TO OPERATE CARRIER

1 Designation of each control lever and its location

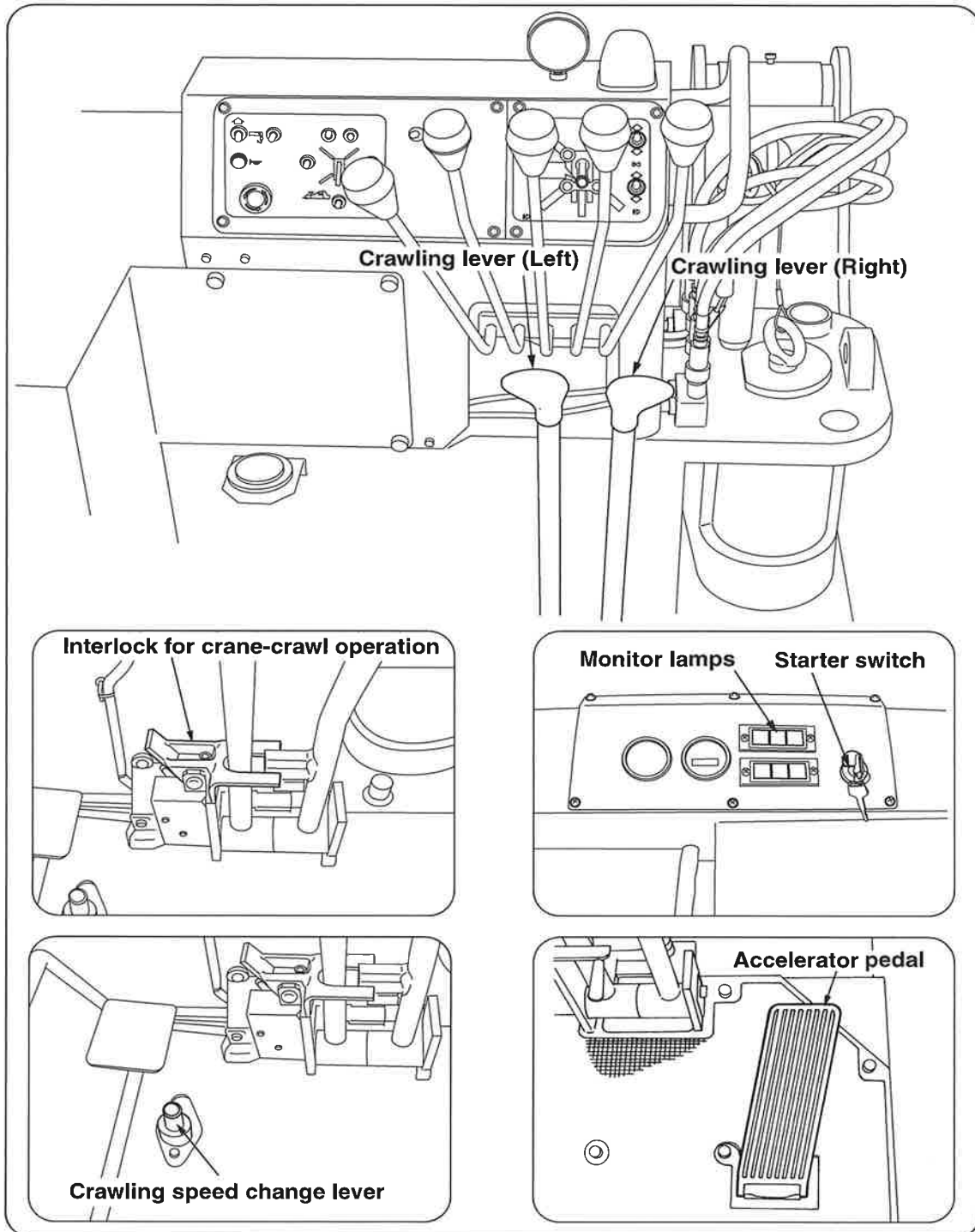

HOW TO OPERATE CARRIER

2 Preparation before operation

! WARNING

- ★Ventilate well when starting the engine in a small limited area or indoors.
- ★Do not start the engine from the outside of the operator's seat.
- ★Confirm the safety around the crane working site before starting the engine.

! CAUTION

- ★Heavy-duty operation of the crane during an initial period after the start of operation may deteriorate its performance in a shorter time. Take approximately 100 hours after the start of operation as a breaking-in period during which abrupt start and acceleration, and continuous operation under heavy load must be avoided.

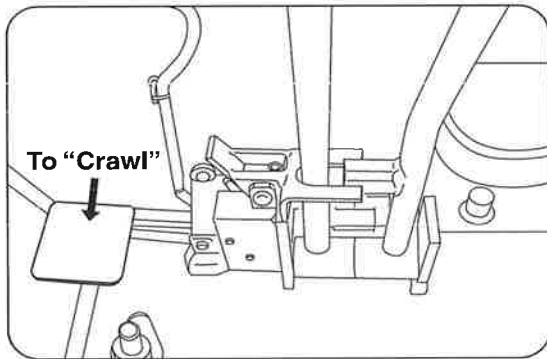

- 1** Press the pedal to release the interlock for crane-crawl operation and hold it. (When you take your foot off the pedal, crawling levers are locked automatically.)

- 2** Make sure that both crawling levers (left and right) are at their neutral positions.

HOW TO OPERATE CARRIER

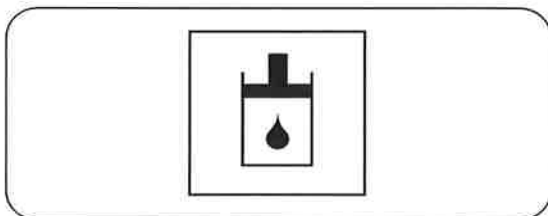
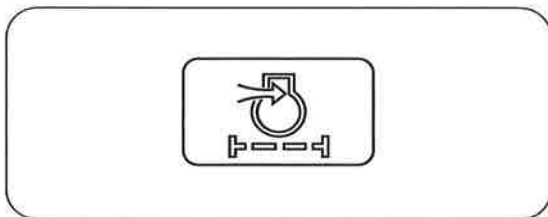
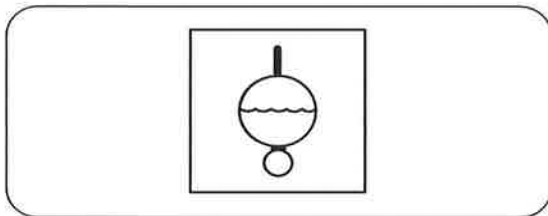
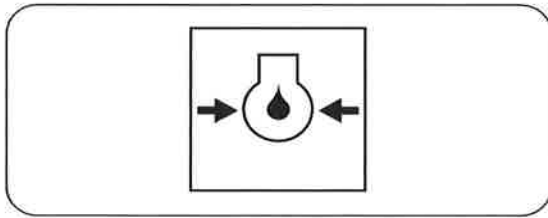

3 Description of warning lamps

●Warning lamp for engine lubricating oil pressure

When engine lubricating oil pressure drops, the lamp lights to tell as it is the failure.

In case where the lamp lights during operation, stop the crane work immediately as it is possible that the engine may seize up and move the crane to a safe place, then stop the engine running for inspection.

●Warning lamp for circulating water temperature

The lamp lights when circulating water temperature has risen to an abnormal level.

Lighting the lamp during operation suggests that the engine has been overheated.

Stop the crane work immediately and idle the engine to wait until the lamp goes out.

Stop the engine running after the lamp has gone off and wait until water temperature has dropped well enough then inspect the cooling system.

●Warning lamp for air cleaner clogging

The lamp lights when air cleaner element has been clogged.

In case where the lamp lights during operation, stop the crane work immediately and move the crane to a safe place to clean up the element or replace it.

●Warning lamp for hydraulic oil temperature

The lamp lights when hydraulic oil temperature has risen beyond the allowable temperature range.

In case where the lamp lights during operation, stop the crane work immediately and idle the engine at lower speed to wait until the lamp goes out.

Stop the engine running after the lamp has gone off and wait until oil temperature has dropped well enough then inspect the hydraulic system.



HOW TO OPERATE CARRIER

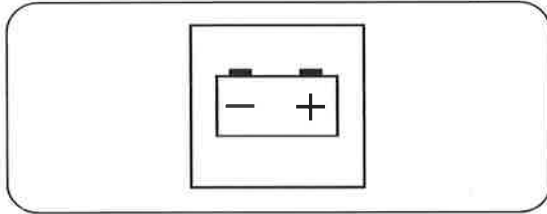

●Warning lamp for alternator (for charging)

The lamp lights when something is wrong with the charging system while the engine is running

In case where the lamp lights during operation, stop the crane work immediately and move the crane to a safe place to stop the engine running.

Check the belt for tightness and damage.

Check the electric wiring to alternator and relays for loose connection and/or poor contact.

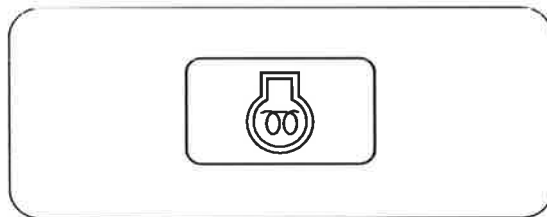

●Pilot lamp indicating preheating engine

The lamp lights when the starter switch is at "HEAT" (preheat) position.

It indicates that electric current is flown through the glow plug.

Holding the starter switch at "HEAT" (pre-heat) position allows the lamp to go out in about 6 seconds to inform that preheating has been completed.

HOW TO OPERATE CARRIER

3 How to operate

WARNING

★ Do not start the engine by using a auxiliary ignition fluid as it may be in danger of explosion.

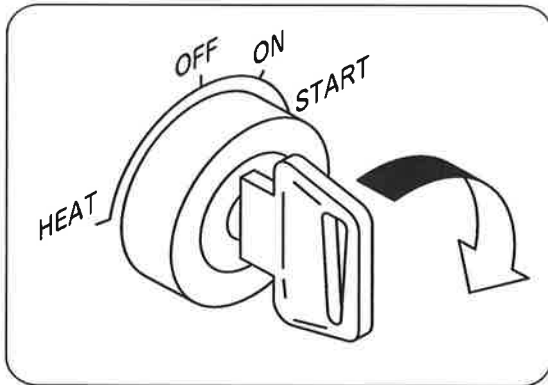

◆ 1. Starting engine

● Starting in normal condition

- 1** Insert the key into the starter switch and turn it to ON position.
- 2** Depress the accelerator pedal by approx. 1/3 of its stroke.
- 3** Turn the switch key to START position to start the engine.
- 4** Release the key after the engine has started running.
The key returns to ON position by itself.

CAUTION

★ Continuous running of starter motor allows the battery to be discharged and the starter motor itself to be damaged.

Do not activate the motor for more than 20 seconds without a break.

★ If it failed to start the engine, take a rest for 1 or 2 minutes to try it again.

HOW TO OPERATE CARRIER

● Starting in a cold weather

When it is hard to start the engine in lower outside air temperature, take steps as follows:

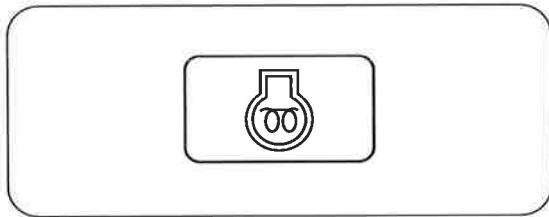

1 Turn the starter switch key to **HEAT** position and wait until the pilot lamp indicating preheating engine goes out. The lamp will go out after about 6 seconds to inform that preheating has been completed.

2 After the lamp has gone off, depress the accelerator pedal fully and turn the switch to **START** position to start the engine.

3 Release the key after the engine has started running. The key returns to **ON** position by itself.

4 Allow the accelerator pedal to stay at a position where it should be depressed lightly after the engine starts running.

5 Release your foot from the accelerator pedal after the engine makes steady running.

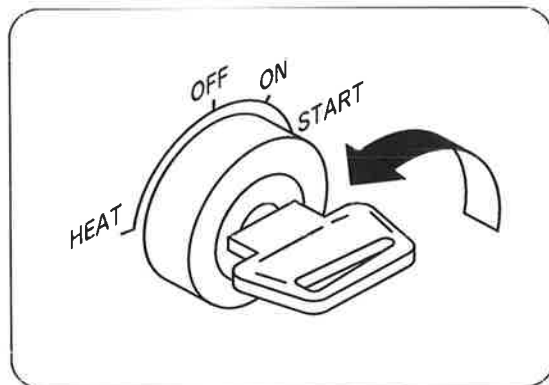



HOW TO OPERATE CARRIER

◆2. Steps to be taken after engine has started

⚠ CAUTION

★Do not make engine to accelerate abruptly before it has been warmed up.

After the engine has started, do not rush into crawling the crane but take the steps as follows:

1 Make sure that each warning lamp does not light after the engine has started. If any one of the lamps lights, stop the engine to find the cause.

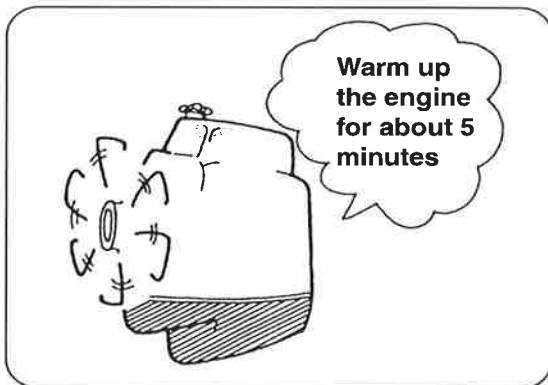

2 After idling the engine at a lower speed for about 5 minutes to warm it up, shift each operation lever with the accelerator pedal depressed halfway to warm up the hydraulic system. The warming-up allows not only the lubricant to circulate well enough through each operating section but also allows the engine to be warmed up gradually to raise temperature of both water and oil which in turn creates the better operating conditions.

3 Check the engine for unusual vibration and noise, bad odor, and for color of exhaust gas.

4 Check the hydraulic equipment and the engine for oil leakage.



HOW TO OPERATE CARRIER

4 How to Crawl

⚠ WARNING

★ Start the crane crawling after the safety around the crawler has been confirmed and make a sign when crawling the crane.

★ Keep anyone away from the crane.

★ Pay special attention when turning left because the left side of crawler will be in your blind spot.

★ Crawl the crane as slowly as possible while making a turn.

★ Run the crane slowly when making a quick turn and crawling on a rough road.

★ Lock the crawling lever with the interlock for crane-crawl operation and stop the engine running before leaving from the crane.

★ When parking the crane on the street is unavoidable, set up safety devices such as a sign, a barricade, and a blinking light so that passing of other vehicles and pedestrians may not be disturbed.

★ Put a pallet against the rubber crawler when parking the crane for a long period of time.

★ Do not park the crane over a place where withered grass or straw, which is flammable, spread. This may cause a fire by heat of exhaust pipe or exhaust hume.

★ When crawling the crane on a water filled area, observe to crawl it within allowable depth of water.

★ In case where the machine is forced to turn on the spot (spin turn), be sure to stop the movement of the machine first, allow the engine to run at a low speed to make it turn slowly and gently.

An abrupt turning not only damages the rubber crawler badly but also causes the machine to bounce from which may invite a very dangerous situation.

HOW TO OPERATE CARRIER

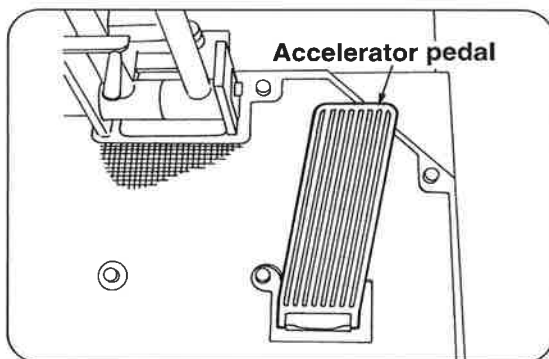
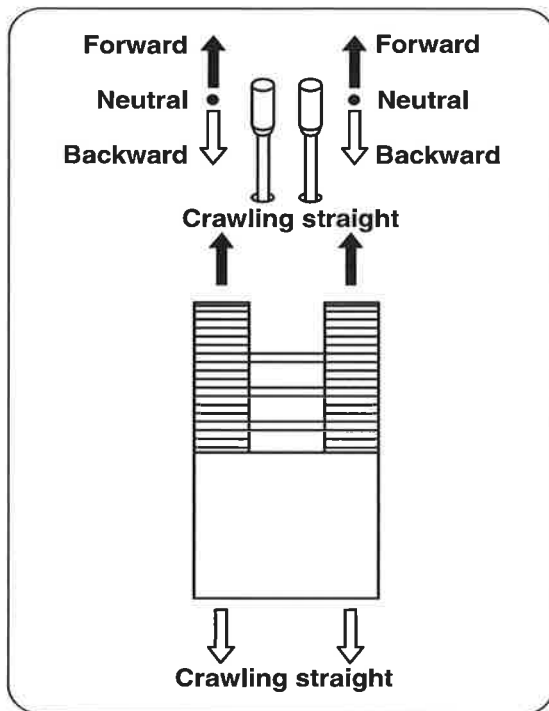

◆ 1. Starting, crawling, stopping the crane

1 Press the the pedal to release the interlock for crane-crawl operation and hold it.

2 While sitting on the operator's seat, shift the crawling levers (left and right) to the other side to make the crane to crawl forward and shift the levers to this side makes it to move backward.

Shifting the levers to neutral allows the brake to be applied automatically.

● Adjustment of crawling speed

When crawling at a slow speed, it is adjusted by how far the crawling levers are shifted. Normal crawling speed is adjusted by how far the accelerator pedal is depressed with the crawling levers shifted to desired direction.

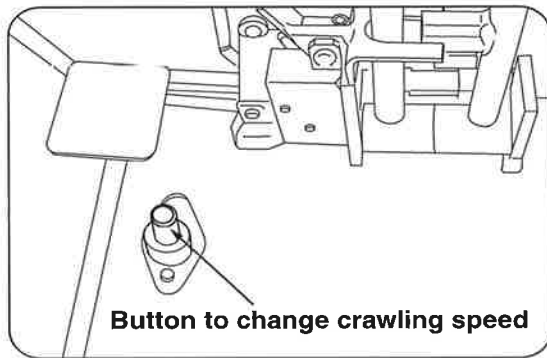

● **Change of crawling speed**

The crane crawls at higher speed while the button to change crawling speed is being depressed.

Release the button to allows the crane to crawl at low speed.

Do not depress the button when crawling a place such as on a slope, on unlevelled ground where crawling resistance is larger

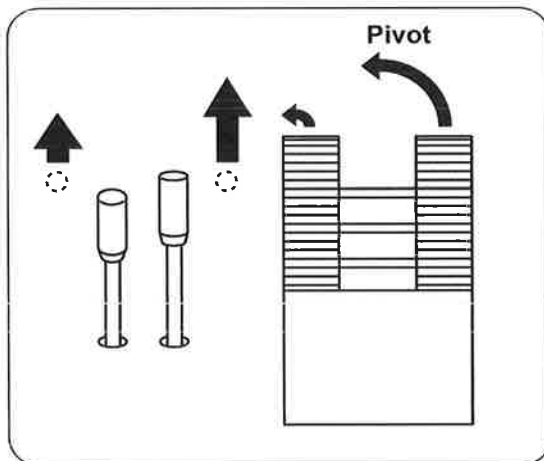

◆ **2. Making a turn**

● **Making a turn while moving**

When traveling forward: It turns to the left (right) by shifting the right (left) traveling lever much further than the left (right) traveling lever.

When traveling backward: It turns to the left (right) by shifting the right (left) traveling lever much further than the left (right) traveling lever

⚠ WARNING

Do not operate the right (left) traveling lever with the left (right) traveling lever put at its neutral position.

Otherwise, the rubber crawler damages and the machine bounces from which may invite a very dangerous situation.

In case where the machine is forced to operate this way, be sure to stop the movement of the machine first, allow the engine to run at a low speed to operate it slowly and gently.

HOW TO OPERATE CARRIER

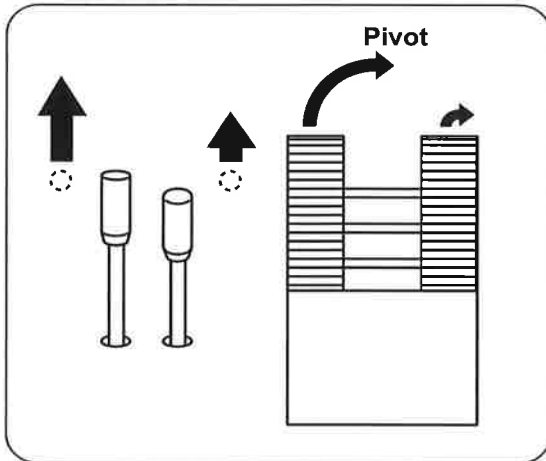

● **Making a turn when the machine is at a standstill**

Shifting the traveling levers both to the right and to the left forward at the same time allows the machine to turn to the right (left) if the left (right) traveling lever is moved much further than the right (left) traveling lever.

Shifting the traveling levers both to the right and to the left backward at the same time allows the machine to turn to the right (left) if the left (right) traveling lever is moved much further than the right (left) traveling lever.

WARNING

Do not operate the right (left) traveling lever with the left (right) traveling lever put at its neutral position.

Otherwise, the rubber crawler damages and the machine bounces from which may invite a very dangerous situation.

In case where the machine is forced to operate this way, be sure to stop the movement of the machine first, allow the engine to run at a low speed to operate it slowly and gently.

HOW TO OPERATE CARRIER

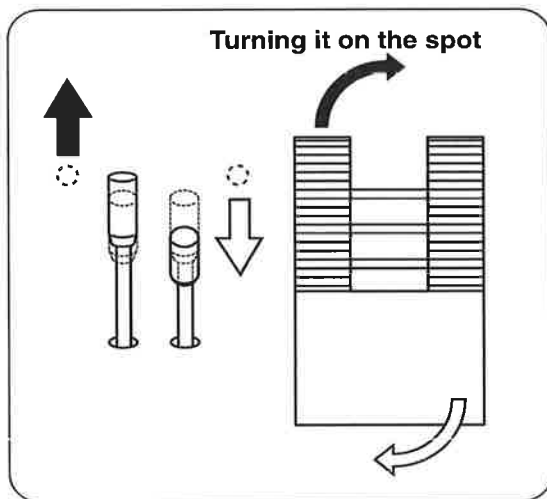

● Making a turn on the spot (spin turn)

As a rule, do not make the machine to turn on the spot.

In case where the machine is forced to turn on the spot, be sure to stop the movement of the machine first and allow the engine to run at a low speed.

Shifting the left (right) traveling lever forward and the right (left) traveling lever backward slowly allows the machine to turn to the right (left) on the spot.

! WARNING

An abrupt turning not only damages the rubber crawler badly but also causes the machine to bounce from which may invite a very dangerous situation.

HOW TO OPERATE CARRIER

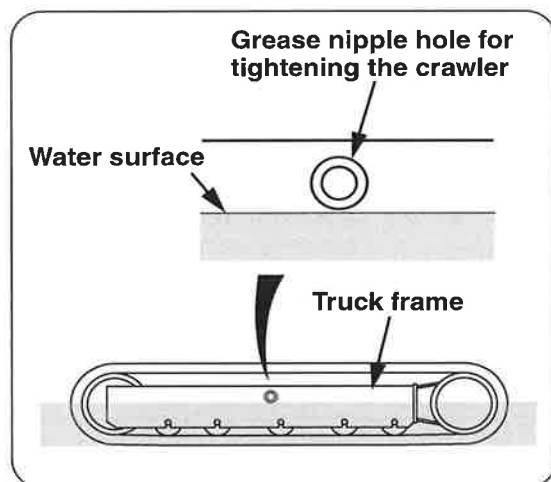
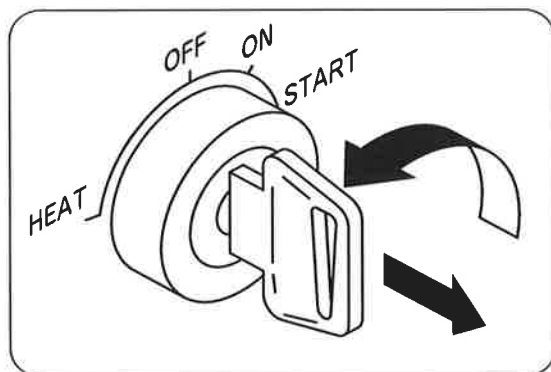
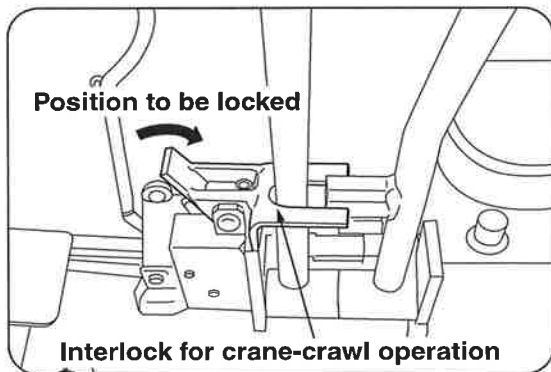

◆3. How to park crane

1 Release your foot from the accelerator pedal to make the engine run at low speed.

2 Shift the crawling levers on both sides to neutral position and release your foot from the pedal to lock the interlock for crane-crawl operation.

1 Insert the key into the starter switch and turn it to ON position.

2 Depress the accelerator pedal by approx. 1/3 of its stroke.

3 Turn the switch key to START position to start the engine.

4 Release the key after the engine has started running. The key returns to ON position by itself.

◆5. Allowable depth of water

1 When crawling the crane on a water filled area, keep the water surface under the grease nipple hole for tightening the crawler located on the side of truck frame.

11. HOW TO OPERATE CRANE

1 Designation of each control lever and its location

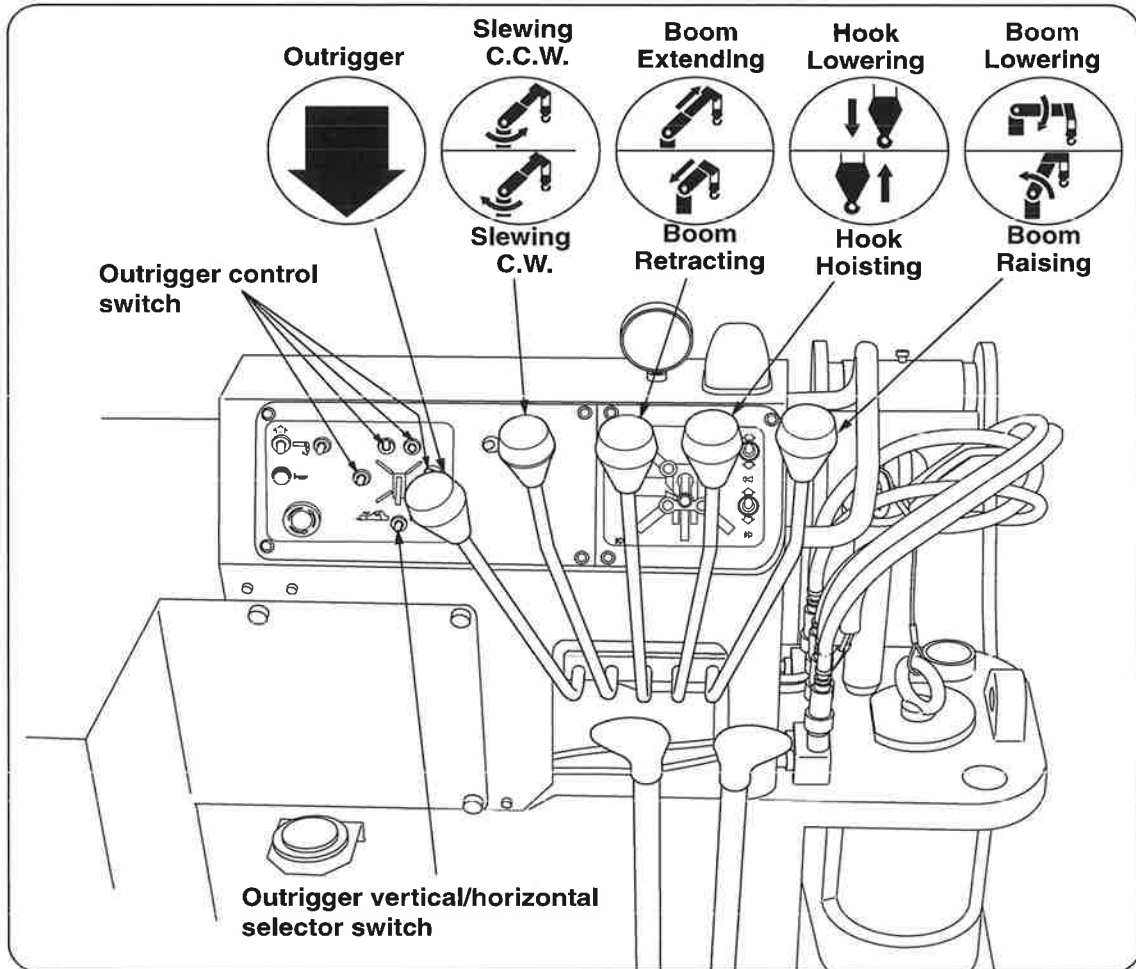

HOW TO OPERATE CRANE

2 Preparation before operation

! WARNING

★ Do not let anyone stand under the hook as it swings when it is released from the store position. Failure to do this may invite an accident.

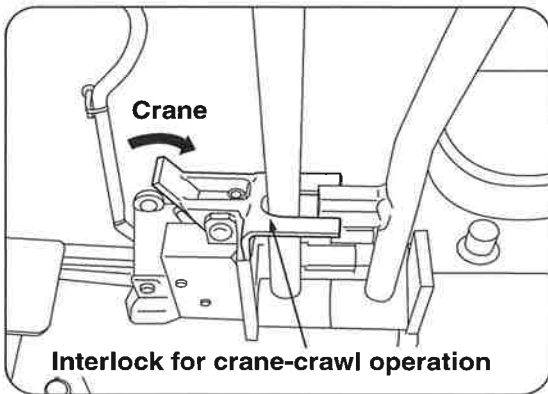

- ① Make sure that each lever for controlling the crane and the outriggers is at its neutral position.
- ② Start the engine. (Hydraulic pump is directly connected to the engine.)
- ③ Make sure crane-crawl levers are locked.
- ④ Turn the operation mode switch to outrigger mode. (Outrigger mode indicator lamp goes on.)
- ⑤ Turn ON the voice switch.

! CAUTION

★ In winter time, do not rush to operate the crane even after the steps illustrated above, preparation before operation, have been completed. Run the hydraulic pump for a while to warm it up.

★ Since viscosity of hydraulic oil is too high when the oil temperature is low, high-speed running of hydraulic pump fails the oil to be circulated so that the pump may be damaged.



HOW TO OPERATE CRANE

3 Inspection before starting crane operation

Before starting crane operation, be sure to check in accordance with procedures below that the control box functions normally.

●Remarks

Since power to the “control box” is to be controlled by the engine key, it is energized automatically when starting the engine and indication [$\square F$] on the “mode indicator lamp” in the “control box” lights.

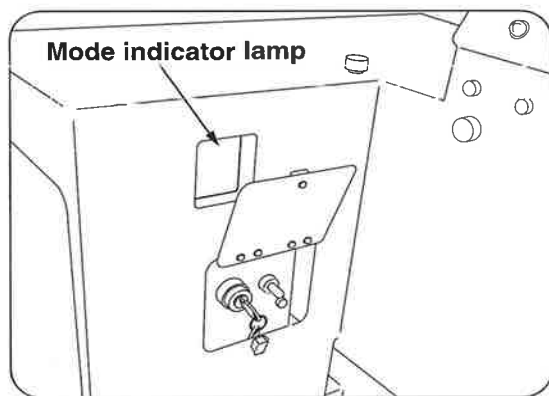

1 Inspection of mode indicator

The “mode indicator lamp” makes a full lighting of [$\square F$] for approx. 2 sec. when extracting the set pins for outriggers to turn the outriggers to their specified positions manually and then all 4 pieces of set pin have securely been inserted again.



HOW TO OPERATE CRANE

2 System diagnosis

The crane is in the process of system diagnosis while the “mode indicator lamp” is making a full lighting.

Following items are to be checked by the system diagnosis.

- Checking if electronic circuit in the control box is functioning properly.
- Checking if manual control lever is at its neutral position.

CAUTION

★Do not operate the crane while the system diagnosis is being carried out.

If the crane is operated during the system diagnosis, voice message, “Beep, Service remote control, Service remote control”, sounds and the crane is turned into inoperable conditions.

If this happened, restart the engine.

If it found normal after the system diagnosis, the mode indicator lamp lights numbers. (In case of manual specification, the number [54] is to be indicated.)

Refer to the section “18. Mode indicator lamp” for detail.

CAUTION

★If the “mode indicator lamp” fails to make a full lighting or voice message, “Beep, Service remote control, Service remote control”, sounds despite the fact that the crane has not been operated, store the crane according to the section “9  ◆2 How to reset when automatic stop for over-winding is found to be out of order” and ask a UNIC authorized service shop for repair.



HOW TO OPERATE CRANE

4 Procedures to set up outriggers

! WARNING

★Crane operation without setting up the outriggers is strictly prohibited.

★Do not operate the crane and extend the vertical cylinders and inner boxes while outriggers have been stored.

★When setting up the outriggers on a rough ground or on a slope, be sure to place a support (such as plank, steel plate etc.) under the outrigger foot flanges to keep the crane level.

In addition, when the crane is to be operated on a soft ground, take the same measures to prevent the outrigger foot flanges from sinking into the ground when a cargo is lifted up.

Setting up the crane on a ground where it is not solid and firm enough may cause it to be overturned.

★Do not put your foot under the outrigger foot flange while outriggers are being extended.

It may invite such accident as that the foot may be crushed by the outrigger.

★Operation with the crane kept leaning makes it unstable when a cargo is lifted up.

Such operation can cause the outriggers to be damaged and the crane to be overturned.

★The rated load is to be changed according to how far (maximum, halfway, minimum) the outriggers are extended.

Be sure to consult the “sticker concerning outrigger extension” for the rated load corresponding to each extension.

★In normal crane operation, set up the crane level on a solid and firm ground with the outriggers fully extended and lift up the crane body by approx. 50mm above the ground.

★When outriggers are extended or being stored, be sure to insert the set pins so that the outriggers may not be rotated unexpectedly.

★When setting up outriggers on the ground with the vertical cylinders, carry it out after the inner boxes have been extended. (Do not extend an inner box any more after the outriggers have been set up on the ground.)

HOW TO OPERATE CRANE

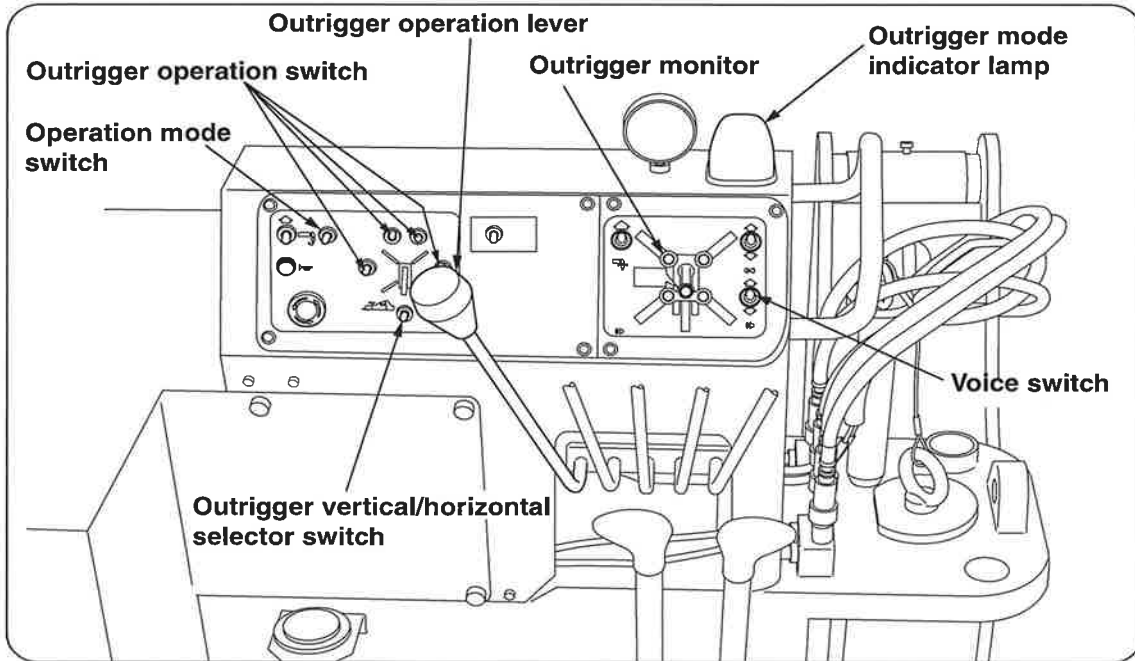

There are 4 outrigger operation switches and each switch is numbered. Select an outrigger control switch to throw it to desired function and operate the outrigger lever accordingly.

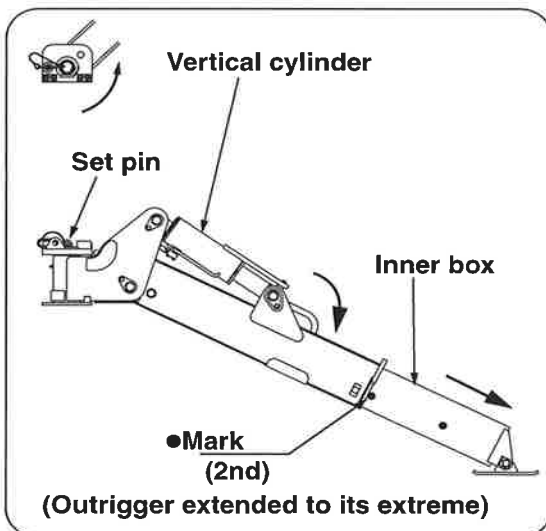

Set up the outriggers as follows:

- 1** Turn ON the voice switch.
- 2** Extract the set pins for outriggers to turn the outriggers to their specified positions manually from their stored conditions. When 4 pieces of set pin have securely been inserted again, voice message, "Remote control ready", is issued. Check that 4 lamps indicating extension of outrigger in the outrigger monitor light. The outriggers will not be operated unless the set pins at 4 places are all inserted.



HOW TO OPERATE CRANE

3 Check that the operation mode is selected to “OUTRIGGER” at this time and voice message, “Change control mode”, sounds and the outrigger mode indicator lamp on the control panel lights.

If the outrigger mode indicator lamp fails to be lit, turn the operation mode switch to “OUTRIGGER”.

4 Turn the outrigger vertical/horizontal selector switch to “HORIZONTAL”.

The voice message, “Change control mode”, is heard.

The voice message will not be issued when the switch is turned to the mode already selected.

5 Turn the outrigger operation switches (4 places) to “EXTEND” and pull outrigger operation lever toward you to extend the inner box.

6 Turn the outrigger vertical/horizontal selector switch to “VERTICAL”.

The voice message, “Change control mode”, is heard.

7 Pull outrigger operation lever toward you to extend the vertical cylinder to set it up on the ground.

(Do not extend and retract the inner box after vertical member of outrigger has been set up.)

8 Select the outrigger you want to operate with the outrigger operation switch concerned and pull the outrigger operation to extend and retract the outrigger while monitoring a level so that the crane body can keep level with the crawler raised by approx. 50mm.

(Since two or more of outriggers cannot be extended or retracted at the same time, extend or retract outriggers separately.)

HOW TO OPERATE CRANE

10 Turn the operation mode switch to “CRANE”.

The voice message, “Change control mode”, is heard and the yellow lamp goes off.

11 Unwind the hook by controlling the hook winding up/down lever to loosen it from its stored position.

Do not stand under the hook as it may swing during this operation.

Unwind the hook until the weight for overwinding alarm is detached from the hook and the alarm buzzer stops sounding.

This can start the crane operation.

WARNING

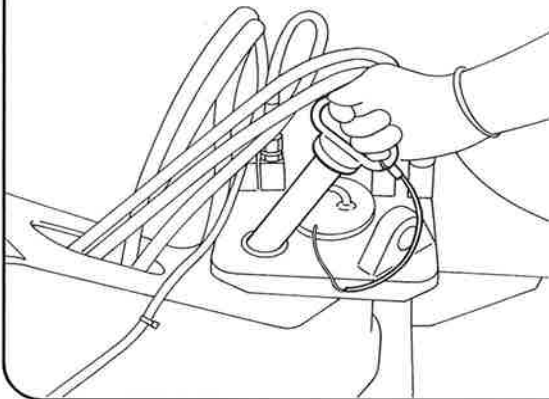

★ Insert each set pin securely when the outriggers are being stored and set up on the ground. Insufficient insertion of the set pins allows a set pin to come off which in turn may make the crawler to lose balance causing the crane to be overturned.

DANGER

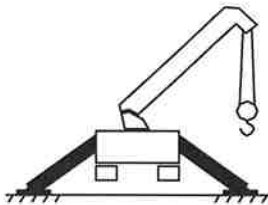

★ Before operating the crane it is mandatory to set up all the outriggers.



HOW TO OPERATE CRANE

◆ Extension of outriggers and rated load

⚠ WARNING

★ Since the rated load varies how the outriggers are extended, the rated load has been set for respective extended conditions. Operate the crane within the load which has been set at each outrigger extension.

★ When each of 4(four) outriggers is set to different extension, operate the crane 360° by applying the worst extended capacity.

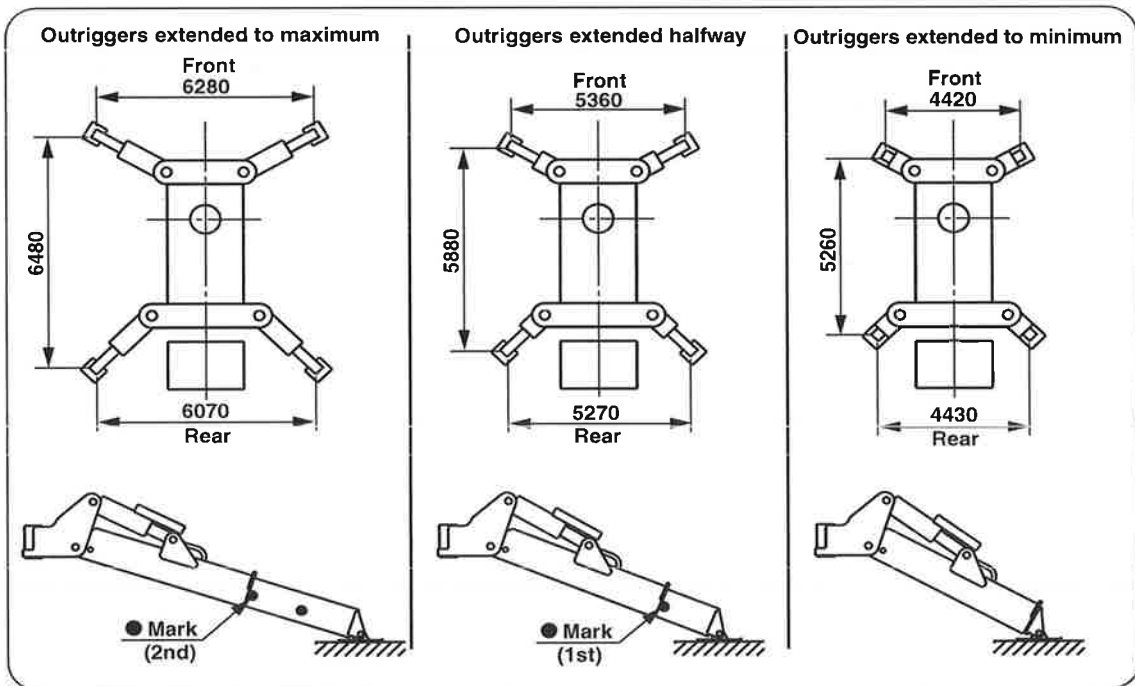

HOW TO OPERATE CRANE

**5 How to operate boom for derricking
(raising and lowering)**

! WARNING

★An abrupt crane operation while a cargo is being lifted up gives an excessive shock to the crane which may cause the crane to be damage or the crawler to be overturned.
Be sure to control levers slowly.

★The longer the boom is extended, the faster a cargo is lifted up and down by boom derricking operation.
Operate the boom so that a cargo can be lifted up slowly.

★When lowering boom with a cargo hoisted, the working radius increases which in turn decreases the capacity specified in the rated load chart.
Check the readings of load indicator to confirm the safety before the boom is lowered.

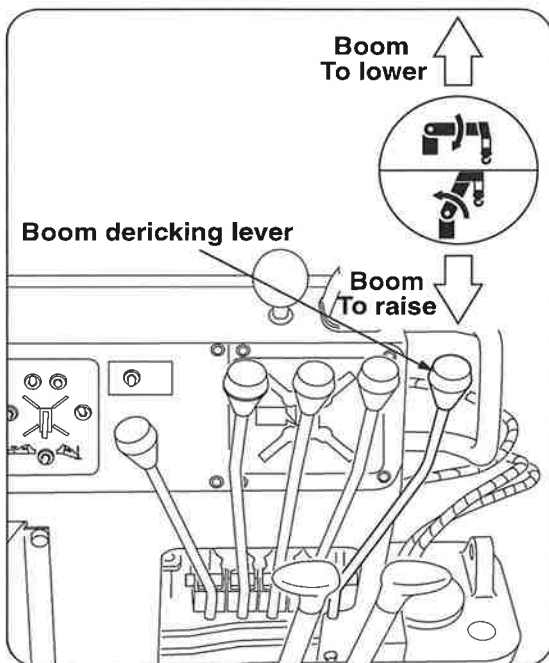

To raise
Shift the lever to "RAISE" to raise the boom.
To lower
Shift the lever to "LOWER" to lower the boom.
To stop
Return the lever to neutral position to stop the boom derricking

◆**Power automatic accelerator**

When the control lever is shifted further to "RAISE" or "LOWER", the engine speed increases according to the movement of the lever which in turn increases derricking speed of the boom as the lever is interlocked with the accelerator.

◆**Boom control together with accelerator pedal**

Engine changes from the idling to the highest speed.
Operate the boom by controlling boom derricking lever together with by adjusting the accelerator pedal.

HOW TO OPERATE CRANE

6 How to hoist and lower the hook

⚠ WARNING

★ Pay attention that the hook will not be over-wound. Be sure to turn ON the "voice switch".

★ If the hook hits against the boom top due to being overwound of the hook, it may cause damage to the wire rope and the sheaves at the boom top and may cause the lifted cargo to fall.

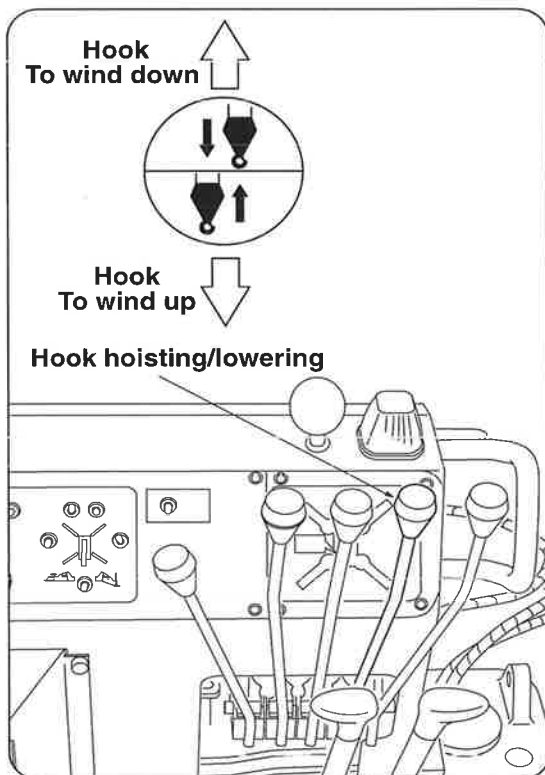

To hoist

Shift the lever to "UP" to raise the hook.

To lower

Shift the lever to "DOWN" to lower the hook.

To stop

Return the lever to neutral position to stop the hook being wound up/down.

◆ Power automatic accelerator

When the control lever is shifted further to "UP" or to "DOWN", the engine speed increases according to the movement of the lever which in turn increases hoisting speed of the hook as the lever is interlocked with the accelerator.

◆ Hook control together with accelerator pedal

Engine changes from the idling to the highest speed.

Operate the boom by controlling boom derricking lever together with by adjusting the accelerator pedal.



HOW TO OPERATE CRANE

⚠ CAUTION

★Further paying out of the wire rope after the hook has reached the ground causes the rope to be wound around the drum irregularly. Lifting up a cargo with the rope irregularly wound on the drum damages the rope which results in remarkable shortening of its service life.

★When paying out wire rope longer such as down to underground work site, make sure that more than 3 turns of wire rope shall always be left on the drum.

★When the first layer of wire rope fails to be wound around the drum firmly and regularly, ropes wound over the first layer may dig into the inner layers to cause an irregular winding. When the wire rope is unwound to or wound up from the first layer of rope, wind it up/down slowly so that the first layer of rope can be wound around the drum firmly and regularly.

★Stop the crane operation when hydraulic oil temperature exceeds 80°C.

Oil temperature is apt to rise easily if repeated operation of winding up/down of the hook, especially in a high lift, is required.

■ To know approximate oil temperature by sense of touch:

| | |
|------|---|
| 70°C | You can touch the oil tank (Lower part) with the palm of your hand for 3~4 seconds. |
| 80°C | You can touch the oil tank (Lower part) with your finger tip for 1~2 seconds. |
| 90°C | The moment you touch the oil tank (Lower part), you will let the hand off by reflex action. |

HOW TO OPERATE CRANE

7 How to telescope boom

! WARNING

★If the boom is extended further with the hook come close to the boom top, the hook may hit against the boom top causing the wire rope and the sheaves at the boom top to be damaged, and the fall of lifted cargo may result.

★Be sure to turn ON the “voice switch”.

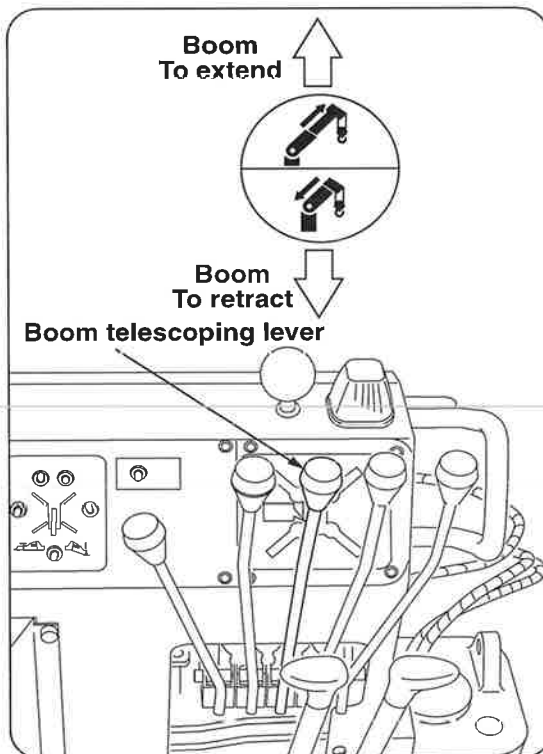

To extend
Shift the lever to “EXTend” to extend the boom..
To retract
Shift the lever to “RETract” to retract the boom.
To stop
Return the lever to neutral position to stop the boom telescoping.

◆Power automatic accelerator

When the control lever is shifted further to "EXT" or "RET", the engine speed increases according to the movement of the lever which in turn increases telescoping speed of the boom as the lever is interlocked with the accelerator.

◆Boom control together with accelerator pedal

Engine changes from the idling to the highest speed.
Operate the boom by controlling boom telescoping lever together with by adjusting the accelerator pedal.

! CAUTION

★The hook is lifted up as the boom extends and is lowered as it retracts.

When telescoping the boom, pay attention to where the hook is.



HOW TO OPERATE CRANE

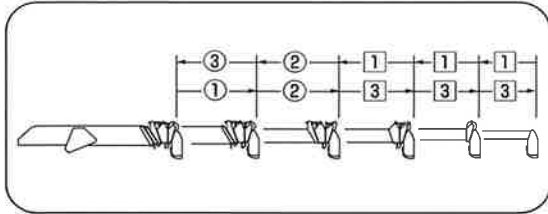

Sequence of boom extension

The boom is to start extending from outer sections of boom.

Sequence of boom retraction

The boom is to start retracting from top sections of boom.

●Remarks

Sections of boom shown in the box indicate that they are telescoping simultaneously.

●Remarks

★When telescoping speed of boom is decreased due to high viscosity of oil during winter time or in low temperature environment, try telescoping the boom to and from one-cycle between both extremes, the shortest and the longest, to recover the speed as the oil in the boom is discharged to be replaced with warm oil.

HOW TO OPERATE CRANE

8 How to slew boom

⚠ WARNING

- ★ Carry out slewing operation slowly without racing the engine.
- ★ Slewing without outriggers set up is strictly prohibited.
- ★ Control levers slowly to allow the boom to make a smooth start and stop for slewing.
An abrupt lever control with a cargo hoisted allow it to swing which may cause hitting against the other objects and overturn of the crane.
- ★ The longer the boom is extended and the smaller the derricking angle becomes, the lifted cargo moves faster.
Perform slewing operation slowly with the above in mind.

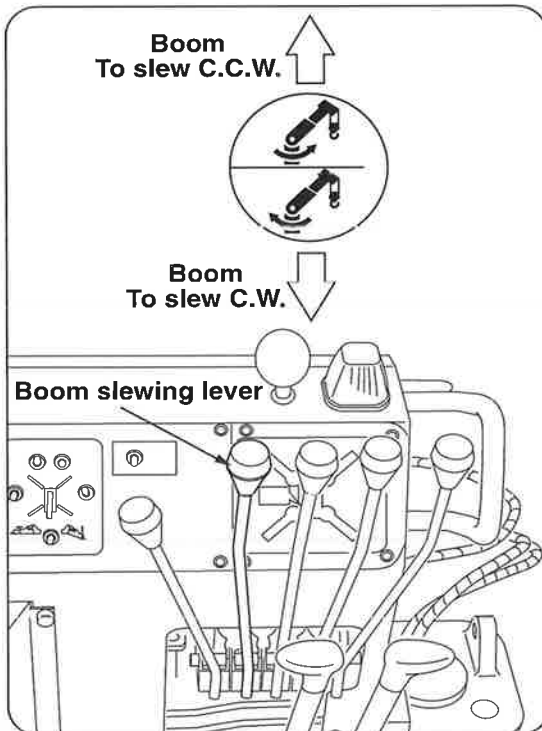

To slew to the right(C.W.)
Shift the lever to "↻" to slew it C.W..
To slew to the left(C.C.W.)
Shift the lever to "↺" to slew it C.C.W..
To stop
Return the lever to neutral position to stop the boom slewing.

◆ **Power automatic accelerator**

When the control lever is shifted further to "↻" or "↺" direction, the engine speed increases according to the movement of the lever which in turn increases slewing speed of the boom as the lever is interlocked with the accelerator.

◆ **Slewing control together with accelerator pedal**

Engine changes from the idling to the highest speed.
Slew the boom by controlling boom slewing lever together with by adjusting the accelerator pedal.



HOW TO OPERATE CRANE

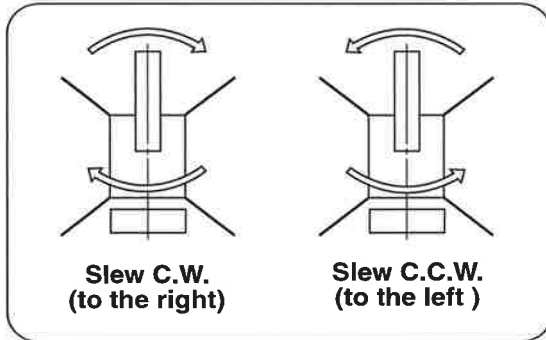

For slewing direction of boom, “slew to the right” means slewing in the direction in which the hands of a clock rotate (C.W.) and “slew to the left” means slewing in the opposite direction of clock hands (C.C.W.) when viewed from the top.

CAUTION

★ Before starting the boom to slew, sound the warning horn to those who are attending or in the working site.

HOW TO OPERATE CRANE

9 How to use extension jib (option)

◆1. Overall view of mounted extension jib

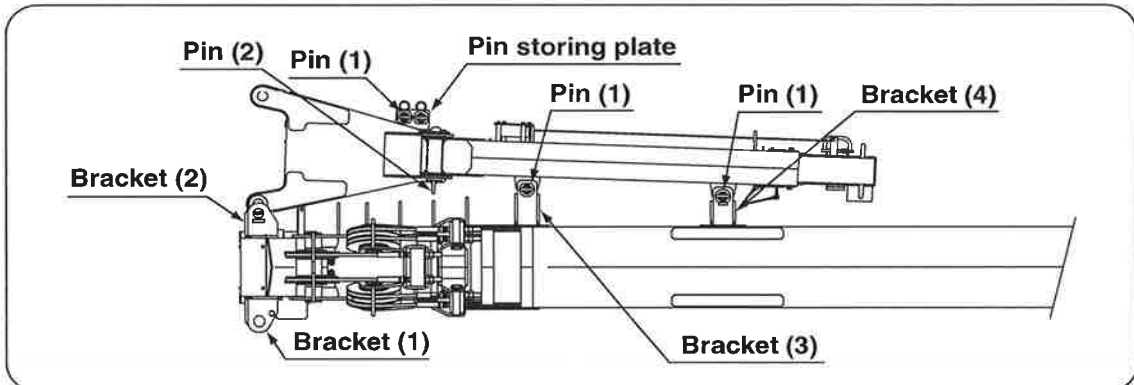

◆2. How to sling wire rope

Replace the hook with that for hooking single rope when using the extension jib.

- ① Take off the wire rope end out of the wire socket to remove the standard hook.
- ② Pass the wire rope through the wire socket and be sure to fasten the rope end securely with wire clip.
- ③ Fasten the wire socket to the retaining part of wire socket in the hook for single rope.

! CAUTION

★When the extension jib is used, slow down the speed of slewing and raising/lowering of the boom to avoid overturn because the boom makes larger lateral deflection and/or swaying.

★Since the wire socket makes an abrupt rotation inside of the hook for single rope when putting a lifted cargo down on the ground, pay special attention to working slinging cargo.

HOW TO OPERATE CRANE

◆3. How to operate extension jib

The extension jib is installed at the side of boom.

When working the jib, extract the pin on the side of boom to fasten the extension jib to the boom top with pins

1 Storing position

Before storing the extension jib, fasten the jib to brackets (3) and (4) in the boom (1) with the pins (1).

Be sure to store the extra pins (1) at the pin storing plate in the jib.

★Check that any one of the pins (1) has not been inserted in brackets (1) and (2) located at the boom top.

2 How to set extension jib

- ① Retract the boom fully. Otherwise, insertion and/or extraction of the pin may become impossible.

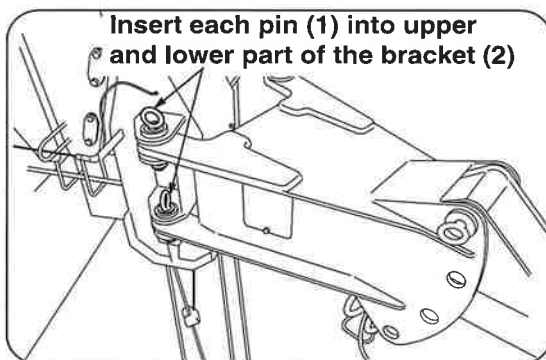
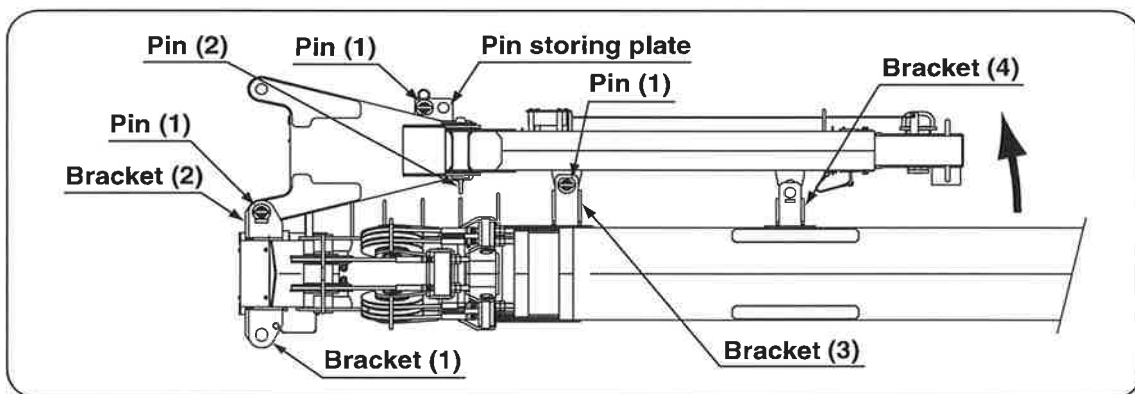

- ② Extract the pin (1) out of the bracket (4). Rotate the extension jib with the pin (1) inserted into the bracket (3) at its center.

HOW TO OPERATE CRANE

- ③ Insert the pins (1) extracted out of the bracket (4) and the pins (1) stored in the storing plate into bracket (2) at the boom top both on upper and lower sides.

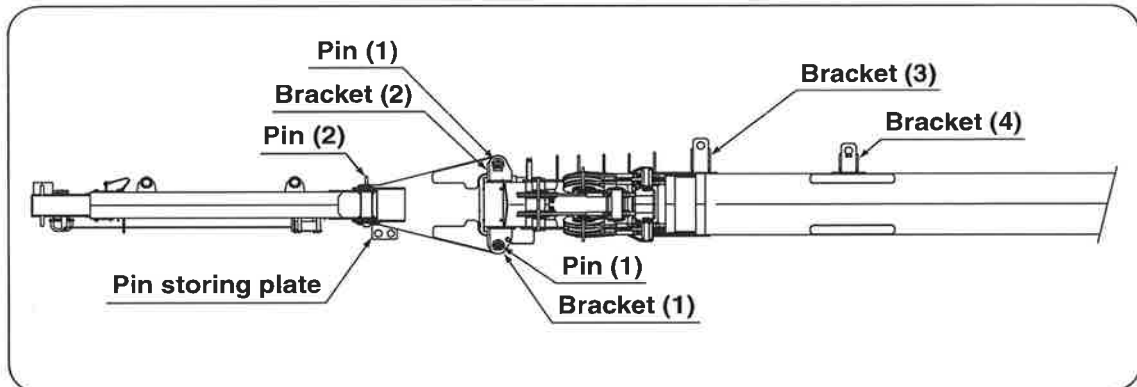

- ④ Extract the pin (1) inserted into the bracket (3) to rotate the extension jib with the pin inserted into the bracket (2) at its center.
- ⑤ Then disconnect the over-winding alarm detector and the wire harness out of the connector to connect the harness to the connector in the extension jib. Insert the removed connector on the side of extension jib into the connector of the over-winding alarm detector at the boom top (to prevent moisture from being entered).
- ⑥ Insert the pins (1) extracted out of the bracket (3) and the pins (1) stored in the storing plate into the bracket (1) at the boom top both on upper and lower sides.

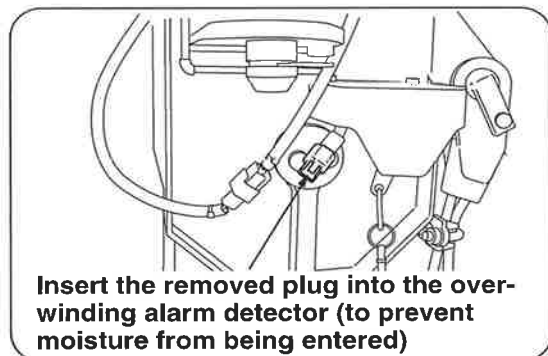
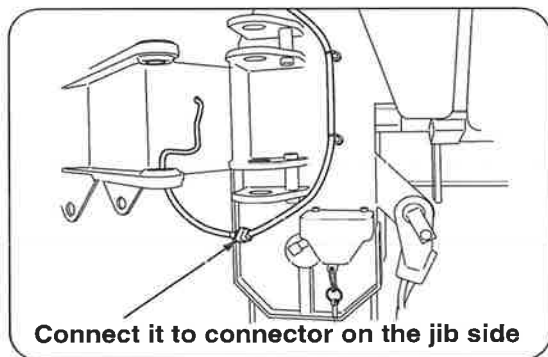

HOW TO OPERATE CRANE

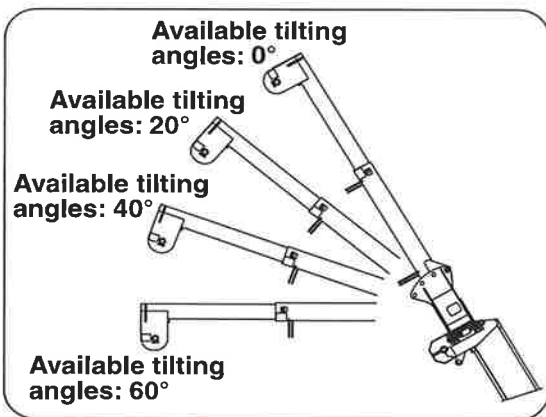
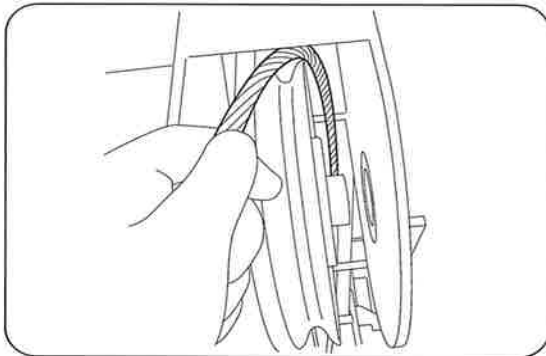
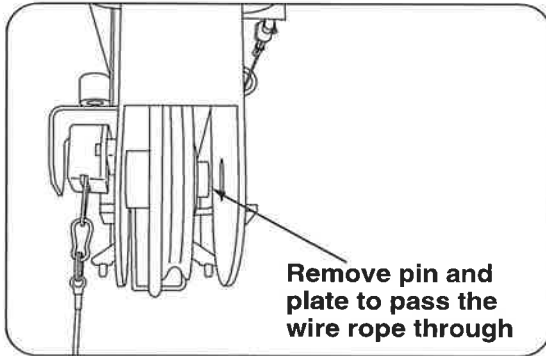

⑦ When using 4-rope hooking system, replace the hook with that for slinging single rope.

⑧ When using single-rope hooking system, the rope can be put on the extension jib without separating the wire socket from the hook.

Pass the wire rope through the wire guide at the lower face of the extension jib, extract the pin fastening the sheave at the top, and put the wire rope onto the sheave through the gap between the sheave and the plate.

⑨ When extending the extension jib, extract the fixing pin to extend it manually.

Be sure to insert the fixing pin after the jib has been fully extended, then check that the retaining pin has securely been inserted.

⑩ When tilting the extension jib, extract the pin (2) while supporting top part of the extension jib, then insert the pin into a hole so that the jib can be tilted to the desired angle.

Since both rated load and working range vary in accordance with the tilted angle, be sure to operate the crane while checking the chart of rated load.

Available tilting angles: 0°, 20°, 40° and 60°.



HOW TO OPERATE CRANE

⚠ CAUTION

★ Before the extension jib is to be rotated, check that 2 pieces of pins have been inserted into the bracket (2).

★ Be sure to check each fixing pin has securely been inserted before starting operation of the extension jib.

★ When telescoping the boom with the extension jib placed at its storing position, confirm that no pins (1) are inserted into the bracket (2).

★ After any one of fixing pins has been inserted, be sure to insert its retaining pin.

3 How to store extension jib

- ① Retract both the extension jib and the boom to their extremes.
Otherwise, pins may not be inserted and extracted.
- ② Set the tilting angle of the extension jib to be zero (0).
- ③ Remove the hook for hooking single-rope from the top of jib to put the rope on the main boom.
- ④ Extract 2 pieces of pins (1) out of the bracket (1) to rotate the extension jib with the bracket (2) at its center.
- ⑤ Disconnect the wire harness on the boom side out of the wire harness on the extension jib side to connect it to the connector of over-winding alarm detector.
Insert the plug removed from the over-winding alarm detector at the boom top into the connector of the harness on the extension jib side (to prevent moisture from being entered).
- ⑥ Rotate the extension jib to bring it to its storing position.
Insert the pin (1) extracted out of the bracket (1) into the bracket (3) and store the other pin removed from the bracket (1) in the pin storing plate in the extension jib.
- ⑦ Extract 2 pieces of pins (1) out of the bracket (2) to rotate the extension jib with the pin (1) inserted into the bracket (3) at its center.
- ⑧ Fasten the extension jib to the bracket (4) with the pin (1).
Store the other pin (1) in the pin storing plate in the extension jib.

⚠ CAUTION

★ When telescoping the boom with the extension jib placed at its storing position, confirm that no pins (1) are inserted into the bracket (2).

★ After any one of fixing pins has been inserted, be sure to insert its retaining pin.

HOW TO OPERATE CRANE

10 How to use searcher hook (option)

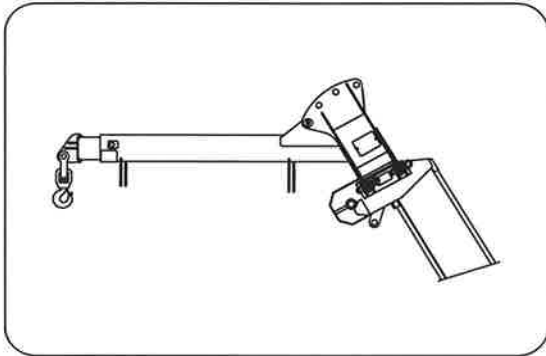

Overall view of searcher hook

1 How to operate searcher hook

The searcher hook is to be used commonly with the bracket and jib (1) of the extension jib.

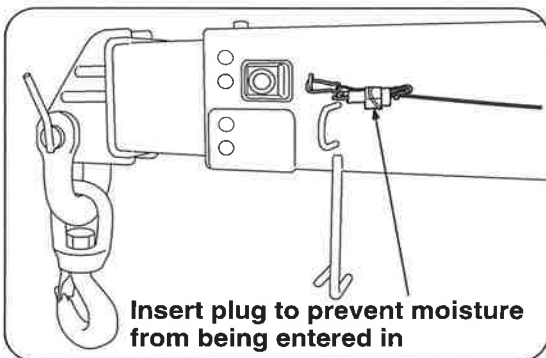
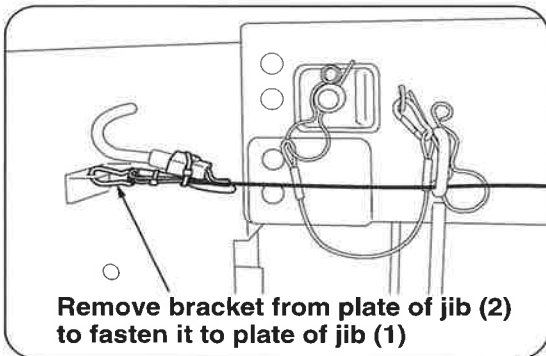

2 How to change extension jib to searcher hook

- ① Unfasten the wire rope end to fasten it on the column (as it will not be used).
- ② Set the extension jib to be operated (at the boom top).
- ③ Remove the weight assembly for over-winding alarm as it will not be used. Connect the wire harness to the over-winding alarm detector as the way when the extension jib is to be used. Insert the plug into the over-winding alarm detector at the boom top to prevent moisture from being entered in.
- ④ Disconnect the connector at the end of cord reel of the extension jib to connect the attached connector instead. Remove the bracket fixed to the plate of jib (2) to fasten it to the plate on the side of jib (1). Then insert also the plug into the over-winding alarm detector of the extension jib to prevent moisture from being entered in.

HOW TO OPERATE CRANE

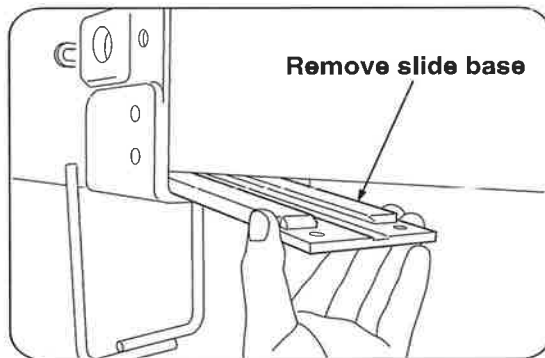
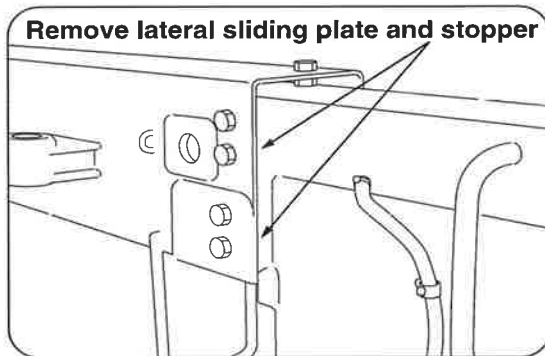

- ⑤ Extract the pin for retaining extension of jib (2).

Remove the lateral sliding plate on the side at the top of jib (1) and the stopper on the upper side.

(Pay attention to the bolt length when mounting the lateral sliding plate, as the bolt length differs in accordance with fastening position.)

- ⑥ Extract the jib (2) by approximately 500mm, lift up the jib (2) at its top, and remove the slide base and the sliding plate mounted at lower side of the top of jib (1) to extract the jib (2).

- ⑦ Insert the searcher hook into the jib (1) to attach the lateral sliding plate and the stopper to the jib (1) as they originally were, then fasten securely the searcher hook by using attached fixing pin and end plate.

- ⑧ Store the components unused in this change carefully as they will be necessary when mounting the extension jib.

HOW TO OPERATE CRANE

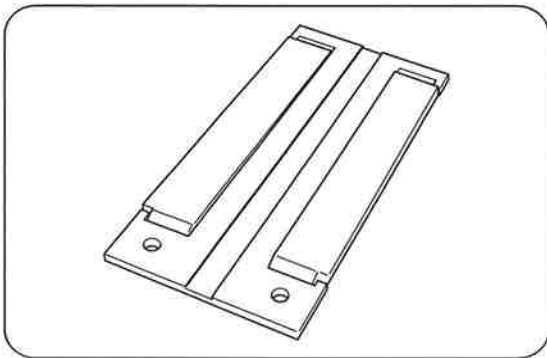

3 How to change searcher hook to extension jib

- ① Remove the pin and the end plate fastening the searcher hook.
- ② Remove the lateral sliding plate and the stopper of the jib (1) to extract the searcher hook.
- ③ Insert jib (2) by approximately 400mm, lift up the jib (2) at its top to attach the slide base and the sliding plate.
When mounting the slide base, attach it so that its groove can direct upper side.
- ④ Mount the lateral sliding plate.
(Pay attention to the bolt length when mounting the lateral sliding plate, as length of each bolt fastening both upper and lower sliding plates differs.)
Attach the stopper on the upper side.
- ⑤ Replace the fixing pin with the pin for fastening and unfastening the extension jib.
- ⑥ Unfasten the end of the cord reel fixed on the side of jib (1) to fasten it on the top side of jib (2).
At the same time, disconnect attached connector and plug to connect the cord reel and the over-winding alarm detector.
- ⑦ Pass the wire rope to fasten the hook for single rope.



HOW TO OPERATE CRANE

11 *How to store crane*

! WARNING

★ Be sure to store the boom from the left hand side of the operator's seat.

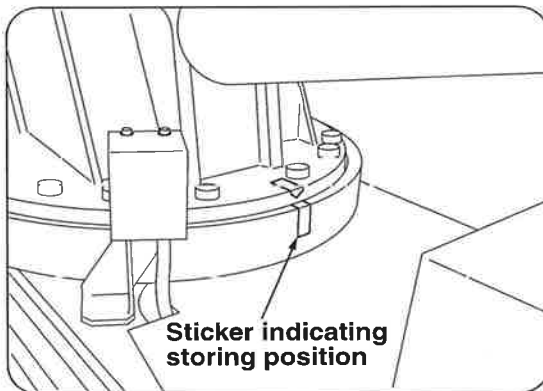

- 1** Retract the boom and bring it to the sticker indicating storing position while slewing it.
- 2** Lower the boom.
- 3** Store the hook.

HOW TO OPERATE CRANE

12 Procedures for storing hook

! WARNING

★Never try operating the crane by controlling the hook storage switch as this is dangerous.

★Store the hook after all boom sections have been retracted and lowered fully.

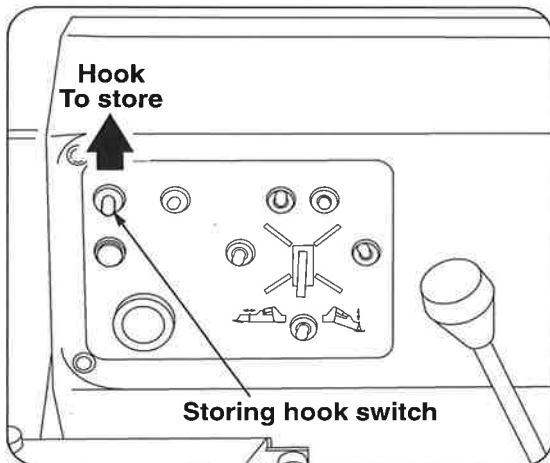

1 Wind up the hook with the “hook winding up/down” lever.

The hook stops being wound up when the hook hits against the weight of overwinding alarm.

2 The hook is to be wound up slowly when the storing hook switch is turned to “STORE” after the hook comes to a standstill.

! CAUTION

★Storing hook while it is swinging may cause the boom, the hook, and the wire rope to be damaged.

HOW TO OPERATE CRANE

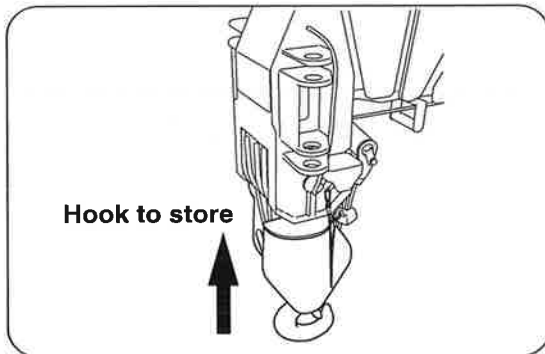

3 When the hook touches the boom top, the hook is to be fixed. Release of the hook storing switch stops storing operation of the hook.

⚠ CAUTION

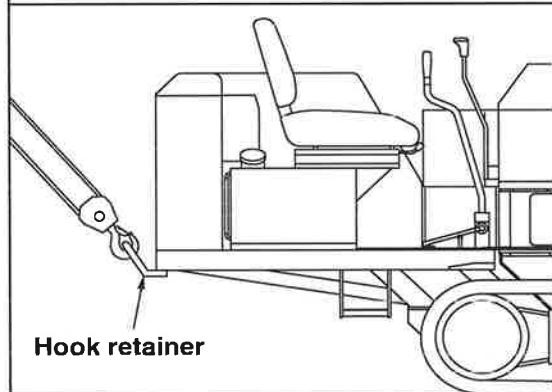

★ If the hook is off the boom top while storing hook, lower the hook once, then carry out storing hook operation again.

★ Be sure to store the hook by using the hook storage switch when storing the hook to the hook retainer mounted at the rear side of the crane.

HOW TO OPERATE CRANE

13 How to store outriggers

! WARNING

- ★ Start storing outriggers after the boom has been stored.
- ★ When storing outriggers, be sure to retract the inner boxes to their extremes after the vertical cylinders have been fully retracted. (Do not retract the inner boxes without the vertical cylinders fully retracted.)
- ★ When storing the outriggers, be sure to insert the set pins so that the outriggers may not be rotated unexpectedly.

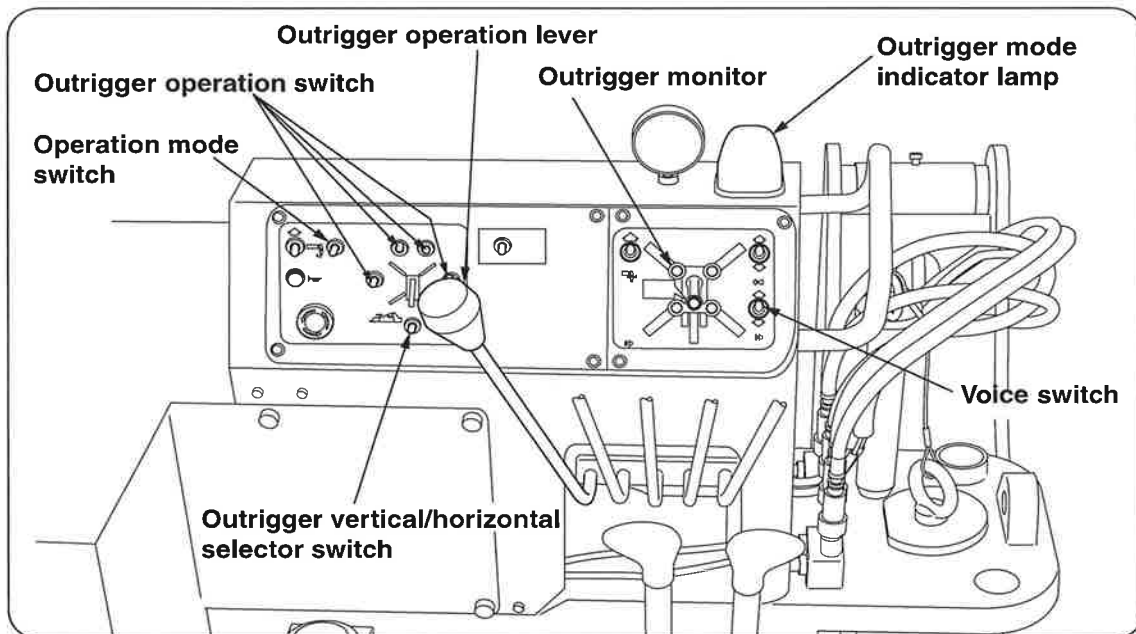

There are 4 outrigger operation switches and each switch is numbered. Select the switch for the outrigger you want to operate and turn it to the desired operation and then operate the outrigger with the outrigger operation lever.

HOW TO OPERATE CRANE

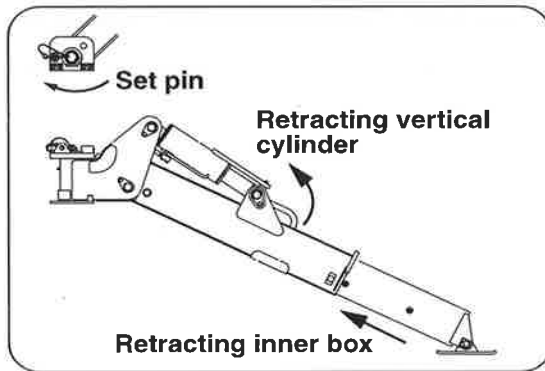

Store the outriggers as follows:

1 Turn the operation mode switch to “OUTRIGGER”.

The voice message, “Change control mode”, is issued and the Outrigger mode indicator lamp on the upper part of control panel lights.

2 The outrigger vertical/horizontal selector switch should be turned to “VERTICAL” at this time.

If it is not, turn it to “VERTICAL”.

The voice message, “Change control mode”, is issued.

3 Turn the outrigger operation switches (4 places) to “STORE” and pull outrigger operation lever toward you to retract the vertical members of outrigger to their extremes.

4 Turn the outrigger vertical/horizontal selector switch to “HORIZONTAL”.

The voice message, “Change control mode”, is heard.

5 Pull outrigger operation lever toward you to retract the inner box fully.

6 Extract the set pins for outriggers to turn the outriggers manually to their storing positions from each extended position.

Insert each set pin securely.

7 Turn OFF the voice switch.



12. U-WAVE, Radio remote control device

1 Request to those who operate the crane

This radio remote control device conforms to regulations for specified small power radio station in the radio wave law.

Use of U-WAVE, “specific low power type” interlocking radio control device, allows the crane operation that will hardly be influenced by radio interference compared with conventional radio remote controllers of weak radio wave type.

In addition, there is no need to get qualification, license, or registration in using the radio remote control device.

Read this manual carefully and understand the contents to use this device.

◆ When making inquiries

When making inquiries, be sure to inform us of model, serial number illustrated on the following label in the remote control transmitter.

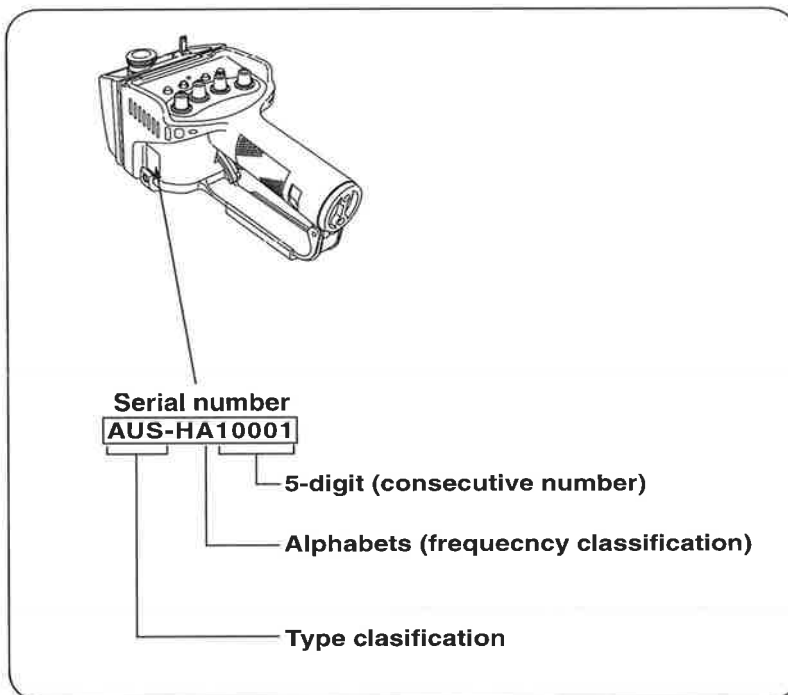

U-WAVE, Radio remote control device

2 Safety precautions

⚠ WARNING

★Observe the cautions for securing safety.
Failure to observe the cautions may invite troubles or serious accidents.

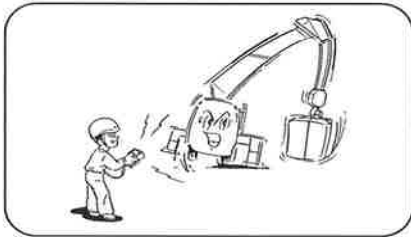

1 In case of crane operation through radio remote controller, pay attention to circumstances around the crane and to the safety especially for the crane that it will not to be overturned as the operator is to control the crane at a distance.

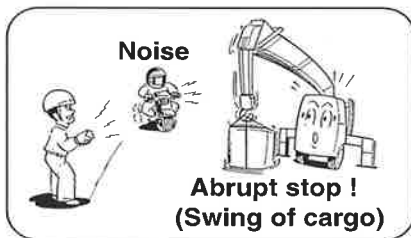

2 Pay attention to the swing of a lifted cargo as the crane may make an abrupt stop when operating it through radio remote control device because it may be affected by radio interference, radio jamming, and noise coming from outside.

In order for the crane system not to be affected easily by noise coming from outside, operate the crane with the following in mind:

- ① Operator must not leave the crane unnecessarily.
Operate the crane within working radius of the crane.
- ② Correct or repair the transmission antenna (located at the stem of transmitter) if it has been distorted or damaged.

●Remarks

Typical source of noise interference:

- Ignition noise emitted from the engines such as of motorcycles or of portable generators.
- Buzzers using contacts such as for alarming when reversing vehicles.
- Electric motors of air-conditioner fan, electric fan, and flashing beacon mounted in cab compartment.

U-WAVE, Radio remote control device

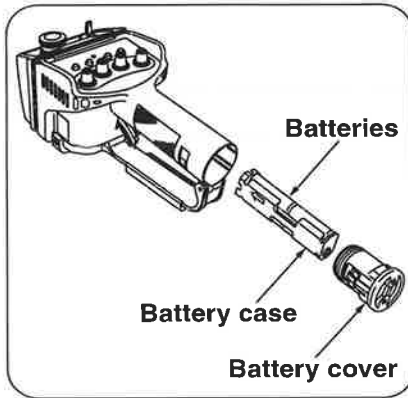

3 Remove the batteries when the transmitter will not be used for a long period of time. Otherwise, leakage of battery may result. Be sure to observe the cautions indicated on the batteries as liquid inside will leak due to wrong use of batteries.

4 Dispose of used batteries in accordance with local regulations.



5 Never try disassembly or alteration of transmitter, receiver, and control box. Do not remove the stay of transmitter as the transmission antenna is built in it.



6 Do not drop or hit the transmitter against something, or give a strong shock, as it may cause damage to the enclosure or breakdown of electronic components. In addition, dropping or giving a strong shock to the transmitter may damage batteries inside causing generation of heat. If the transmitter has been given a strong shock, be sure to check batteries and replace them if damaged.



7 Do not wash the transmitter with water directly. Wipe dirt off the transmitter with a piece of cloth wet with water or diluted detergent. Avoid using an alkaline detergent, an alcohol, or a spraying washing detergent for this purpose as they may cause the plastic housing of transmitter to crack.

U-WAVE, Radio remote control device



8 Do not thrust the control panel in the transmitter and/or control keys with a sharp article as it may make a hole resulting in entering water inside through it.



9 Do not give the transmitter an abrupt temperature change.
An abrupt temperature change may cause a fault due to building-up condensation inside of the transmitter.



10 Do not put or store the transmitter where:

- It is exposed to direct sunlight,
- It is in front of hot air outlet exhausted out of the vehicle, and
- It is close to a heating apparatus or it is too humid.

U-WAVE, Radio remote control device

3 Designation of each equipment

◆1. Construction of radio remote control device

(Showing typical mounting example)

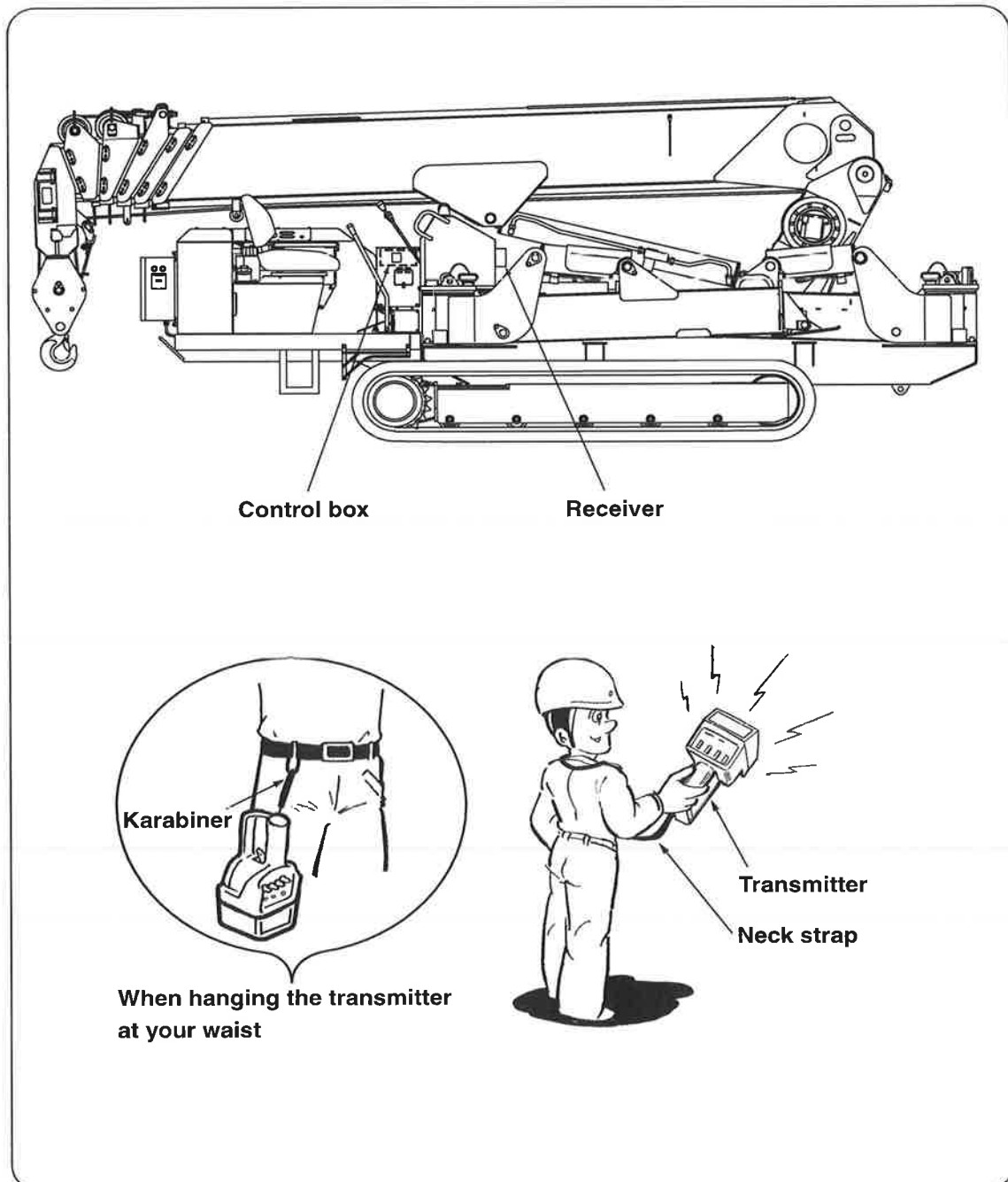



U-WAVE, Radio remote control device

◆2. Designation of each part of transmitter

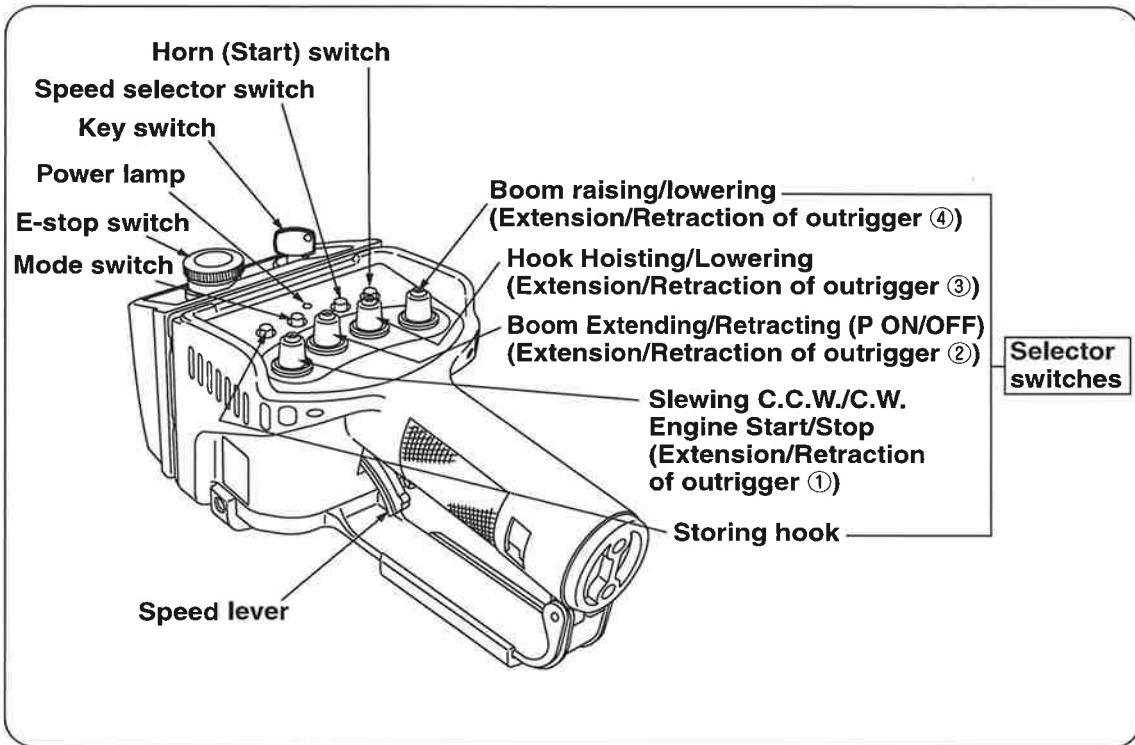

◆3. Designation of each part of receiver

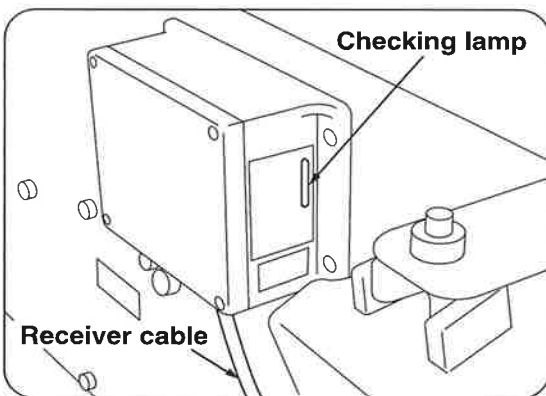

*Receiving antenna is built in the receiver.

U-WAVE, Radio remote control device

◆4. Designation of each part of control box

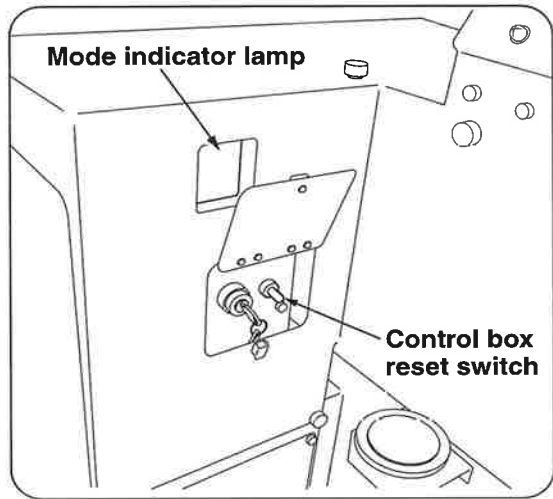



U-WAVE, Radio remote control device

4 Inspection before crane operation

Before starting crane operation, check that the control box functions correctly according to procedures below.

● Remarks

Since power to the “control box” is to be controlled by the engine starter key, it is energized automatically when starting the engine and “mode indicator lamp” in the “control box” lights.

Also, the “power lamp” on the “radio control receiver” blinks in green.

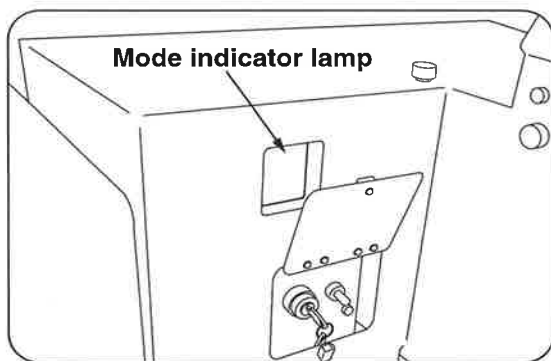

◆1. Checking mode indicator lamp

The “mode indicator lamp” makes a full lighting as in [B.B.] for about 2 seconds after the starter key is turned ON.

◆2. System diagnosis

The crane is carrying out system diagnosis while the “mode indicator lamp” is fully lit up.

What is to be checked during system diagnosis is if:

- Electronic circuit in the control box is functioning correctly,
- Manual control lever is at its neutral position, and
- Radio control receiver is connected to the crane and the receiver functions normally.

! CAUTION

★ Do not make a crane operation while system diagnosis is being carried out.

If the crane is operated during the system diagnosis, voice message, “Beep, Service remote control, Service remote control”, sounds and the crane is turned into inoperable conditions.

If this happened, depress the reset switch in the control box. This starts the system diagnosis again.



U-WAVE, Radio remote control device

If it was found normal after the system diagnosis has been completed, the mode indicator lamp lights either one of following indication and voice message, “**Ping-pong, Remote control ready, Remote control ready**”, is issued.

| Mode | Information | Indication priority |
|------|---|---------------------|
| 00 | Current operation mode is on normal radio remote control mode. | 4 |
| 0F | Current operation mode is traveling mode. | 1 |
| 04 | Current operation mode is on outrigger radio remote control mode. | 2 |
| 10 | Hook hits against weight for over-winding alarm (over-wound condition). | 3 |

- Since priority is assigned for each mode in its information, it is to be indicated in the order of higher priority.

● **Remarks**

If the “mode indicator lamp” indicates [04], current control is on outrigger radio control mode.

No crane operation other than extension/retraction of outriggers is possible.

When operating the crane, turn the “crane/outrigger operation mode selector” switch to “crane”.

CAUTION

★ If the “mode indicator lamp” fails to make a full lighting during system diagnosis, or voice message, “**Beep, Service remote control, Service remote control**”, is issued despite the fact that the crane has not been operated, take measures according to the section 12. 8 ◆3. “**Trouble inspection**” (on page 12-39).

U-WAVE, Radio remote control device

5 How to switch crane operation mode

The crane can be operated either by manual control levers or by the radio remote control transmitter.

Switch crane operation mode to the manual control mode for operating the crane with manual control lever, and to the radio remote control mode for operating the crane through radio remote control transmitter.

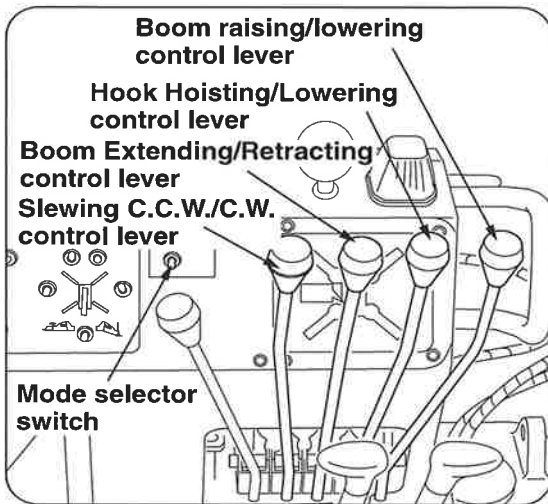

How to switch operation mode

Switching of manual control mode between radio remote control modes is to be made by mode selector switch.

Depression of mode selector switch when operated on manual operation mode allows to switch it into the radio control operation mode and following voice message is issued: "Remote control ready, Remote control ready"

The operation mode lamp lights when switched to the radio control operation mode.

Depression of mode selector switch when operated on the radio remote control mode allows to switch it into the manual operation mode and following voice message is issued: "Crane mode, Crane mode"

The operation mode lamp goes off when switched to the manual operation mode.

The crane can only be operated via manual control levers when it is on the manual control mode but it cannot be operated through the radio control transmitter.



U-WAVE, Radio remote control device

The crane can only be operated through the radio control transmitter when it is on the radio remote control mode but it cannot be operated via manual control levers (including outriggers).

List of available functions to be operated on each control mode

| Crane operation | | Operation mode | |
|----------------------------------|---------------------------|----------------|----------------------|
| | | Manual | Radio remote control |
| Manual lever | Boom Raising/Lowering | ○ | × |
| | Hook Hoisting/Lowering | ○ | × |
| | Boom Extending/Retracting | ○ | × |
| | Slewing C.C.W./C.W. | ○ | × |
| | Outrigger Extend/Retract | ○ | × |
| Radio remote control transmitter | Boom Raising/Lowering | × | ○ |
| | Hook Hoisting/Lowering | × | ○ |
| | Boom Extending/Retracting | × | ○ |
| | Slewing C.C.W./C.W. | × | ○ |
| | Storing hook | × | ○ |
| | Mode | × | ○ |
| | Speed select | × | ○ |
| | Horn | × | ○ |
| | Emergency stop | × | ○ |
| | Engine Start/Stop | — | ○ |

Operation ○: Possible ×: Impossible

● **Remarks**

The crane cannot be operated both by manual and by radio remote control without selecting operation mode.

The operation mode is to be memorized even after power to the crane has been turned OFF.

U-WAVE, Radio remote control device

6 How to operate the crane through radio control operation

◆1. Preparation before operation

1. Extend the outriggers to their extremes with manual control levers to set up the crane body level.

●Remarks

If operation of the crane (such as boom Raising/Lowering, hook Hoisting/Lowering, boom Extending/Retracting, and slewing C.C.W./C.W.) is carried out while outriggers are being extended or retracted by manual control lever, the crane will make an automatic stop to avoid dangerous situation.

(The “Mode indicator lamp” blinks [□□]. Refer to section 18. 1 “Mode indicator lamp” (on page 18-1) for detail.)

If this happened, stop both operation of the crane and of the outriggers once and try carrying out extension and retraction of outriggers again.

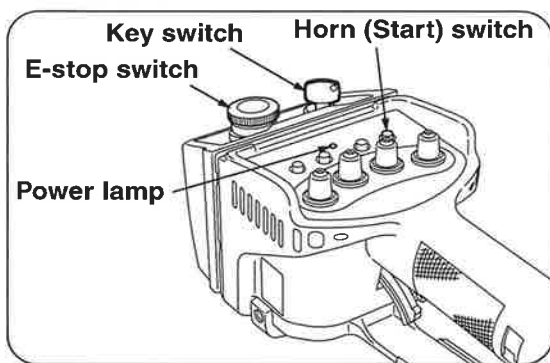

2. Check that the “E-stop switch” on the transmitter has been reset to turn ON the “Key switch”.

If the “E-stop switch” has not been reset, turn the switch clockwise to reset it.

- Emergency stop function is to be actuated if the “E-stop switch” is pushed in, and emergency stop resets when it is not being depressed.

U-WAVE, Radio remote control device

3. Depression of the “Horn (start) switch” on the transmitter energizes the transmitter and “power lamp” lights (in red, in orange, or in green).

- Power to the transmitter is to be turned OFF by pushing in the “E-stop switch”, or by turning OFF the “Key switch”, or if time has passed for more than 5 minutes when no crane operation has been carried out.
- If the “Power lamp” blinks or fails to be lit, replace batteries of transmitter according to the section 12. “◆3.How to replace batteries” illustrated on page 12-36.

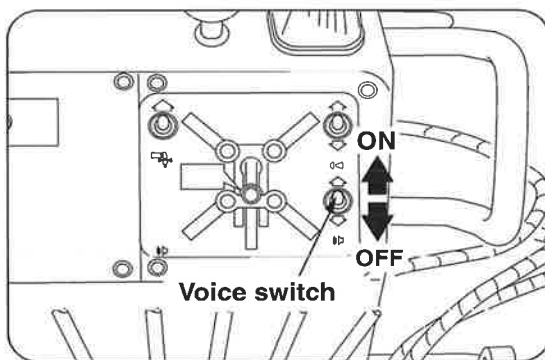

4. Check that the voice switch has been turned ON.
If not, turn it ON.

●Remarks

Voice message will not be issued when the voice switch has been turned OFF.

5. Depress the “Radio remote control selector switch” on the switch panel to turn it to be operated on radio remote control mode.

The mode indicator lamp indicates and the following voice message is issued:

“Remote control ready, Remote control ready”

- When the operation mode is switched to “Radio remote control mode.” with power to transmitter turned OFF, the mode indicator lamp indicates .

Turning ON the power to the transmitter allows the mode indicator lamp to indicate .

U-WAVE, Radio remote control device

◆2. How to operate

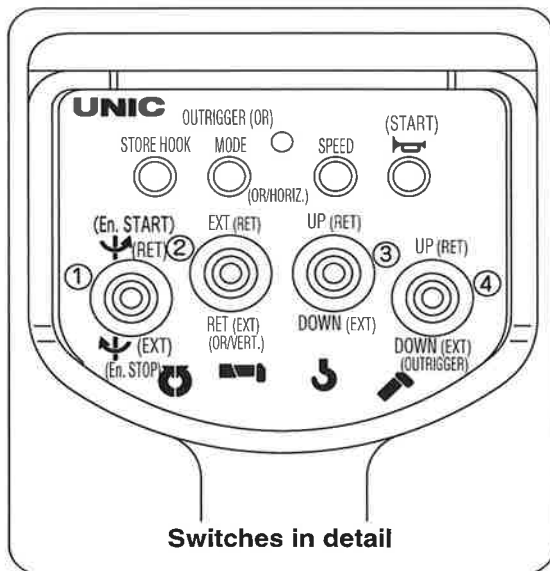
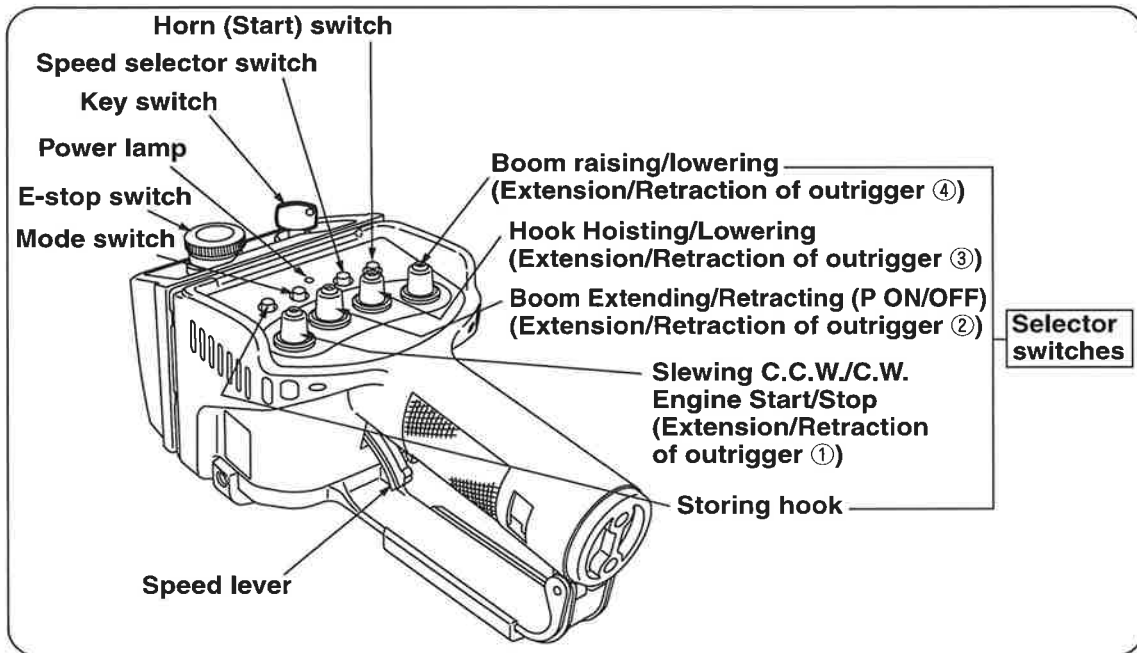

1. Operation of crane function

(1) Throw a corresponding “Selector switch” to the direction allowing the desired crane function.

(2) Pull the “Speed lever” slowly with the “Selector switch” remained as it has been thrown.

If only one of the selector switches is to be operated, the crane starts to move slowly with the engine rotated at a low speed (idling speed) when pulling the “Speed lever” slowly.

When the speed lever is pulled further, the engine speed increases to allow the operation speed of crane to be faster.

● If the “Speed lever” is pulled with more than two “Selector switches” thrown, the engine speed becomes faster than that in case of only one of selector switches is being pulled.

(However, maximum engine speed will not change. Refer to section 6 “Engine speed control function” (on page 12-23) for detail.

U-WAVE, Radio remote control device

! WARNING

★ When operating the crane with the radio remote control transmitter, be sure not to touch any of manual levers as manual levers shift simultaneously.

- (3) When stopping the crane operation, return the “Speed lever” slowly, and then return the “Selector switch”.
- (4) Depression of the “Horn switch” activates the horn on the vehicle.
Use it when calling attention to those who stand around the vehicle.

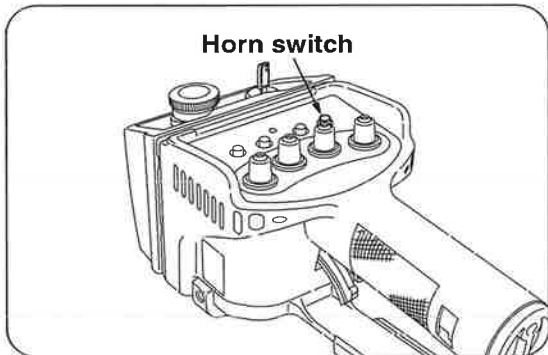

● **Remarks**

- Switches mounted on the remote controller are ON/OFF type which can be actuated with a light touch.
Do not apply strong force as it may cause damage to the switches.
- When the same radio wave (of specified small power radiation type radio system) is being used near the working site, response time of the crane it takes from the time when the radio remote control device has been operated may become longer to some extent which is not a fault.
- When operating with the remote controller, working speed may become a bit slower than that of manual operation.

U-WAVE, Radio remote control device

2. How to confirm and change speed mode

When operating the crane with the engine running at a medium speed, or at a lower speed such as in case of working at night, the speed mode can be changed.

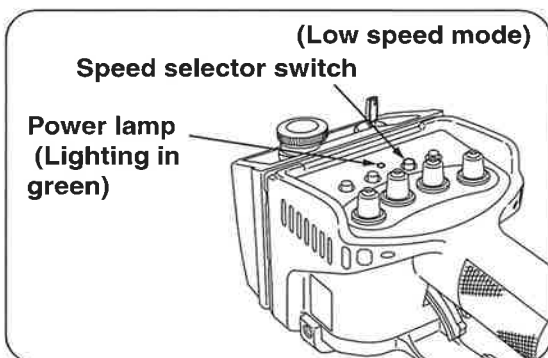
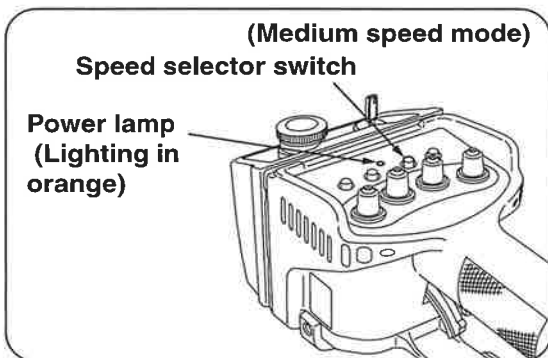
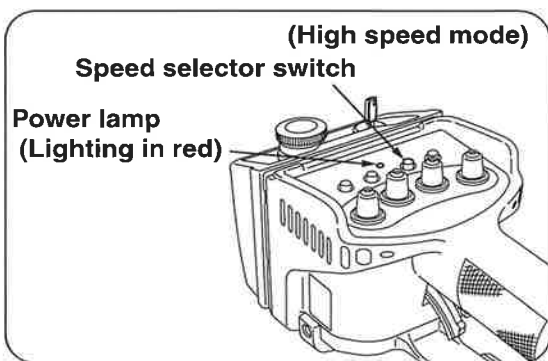

(1) How to confirm speed mode

Check the “power lamp” for lighting color, if it is lit in;

- ① Red : High speed mode
- ② Orange : Medium speed mode
- ③ Green : Low speed mode

If the “power lamp” is not lit, turn ON the power to transmitter to light the “power lamp”.

● Orange illumination is realized by lighting both red and green LED elements.

Red and green LEDs may be seen separately where it is in a lot of sunshine.

(2) How to change speed mode

Confirm that the “Power lamp” is lit to depress the “Speed selector switch”.

Every time the “Speed selector switch” is depressed, the “Power lamp” lights in the order of



changing speed mode accordingly.

Depression of the “Speed selector switch” with the “Power lamp” lit in red allows the lamp to light in orange changing it into on medium speed mode.

Depression of the “Speed selector switch” with the “Power lamp” lit in orange allows the lamp to light in green changing it into on low speed mode.

Depression of the “Speed selector switch” with the “Power lamp” lit in green allows the lamp to light in red changing it into on high speed mode.



U-WAVE, Radio remote control device

●Remarks

Setting of speed mode is to be memorized even when power to transmitter has been turned OFF.

Note that a slight speed difference between swinging C.C.W./C.W. may be found when swinging it on the low speed mode which is not a fault.

(3) Speed mode and manual lever control

Manual lever control is also applied to the speed mode.

High speed modeEngine will run at maximum speed.

Medium speed modeEngine will run at medium speed range.

Low speed modeEngine will run at close to idling speed.

●Remarks

Speed mode can only be changed through radio control transmitter.

Speed mode switches to high speed mode when power to the crane is turned OFF (starter switch is turned OFF).

Since setting of speed mode is memorized even when power to radio control transmitter has been turned OFF, speed mode is switched to the mode as the radio control transmitter has memorized previously when the crane is operated through radio control transmitter after power to the crane is turned ON again.

U-WAVE, Radio remote control device

3. Interlocking balance control function

When interlocking operation (operation of speed lever with more than 2 of “Selector switches” thrown) is carried out through the radio control transmitter, the system equips the function controlling movement of each control lever for each combination of the “Selector switches”.

Therefore, when the speed lever is pulled to its extreme, movement of each control lever varies in accordance with combination of “Selector switches”.

In some cases, the control lever may not be shifted to its full extent despite the fact that the speed lever on the radio control transmitter has been fully pulled which is not a fault.

●Remarks On interlocking balance retaining function:

The crane equips interlocking retaining function which prevent its operating speed from making an abrupt increase when interlocking operation is switched to independent operation,

When operation is switched from interlocking to independent (change from operation of speed lever with more than 2 of “Selector switches” thrown to operation of speed lever with one of “Selector switches” thrown), control speed may become slower as oppose to that of the independent operation, which is not a fault.

In order to correct this, release all the “Selector switches” once and go back to independent operation again.

For immediate returning to normal speed of independent operation when it is switched from interlocking to independent, validity of interlocking balance retaining function can be switched through the transmitter.

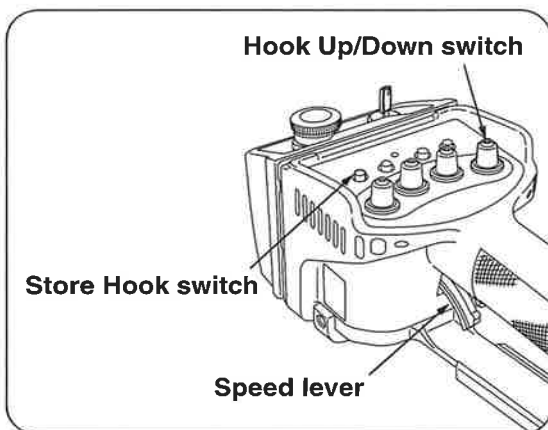

In order for the interlocking balance retaining function to be invalid, depress the “Store hook” switch with the “Boom Up/Down” switch turned to “Down”.

Voice message, “Change control mode, Change control mode”, sounds and the interlocking balance retaining function changes to be invalid.

(The voice message does not sound when the function remains as it was.)

Switching condition of the interlocking balance retaining function can be confirmed as the mode indicator is to be lit as in [$\square F$] (meaning “invalid”) while the switch is being controlled.

U-WAVE, Radio remote control device

● Example of operation

Interlocking operation of both “Boom extending” and “Hook Lowering”.

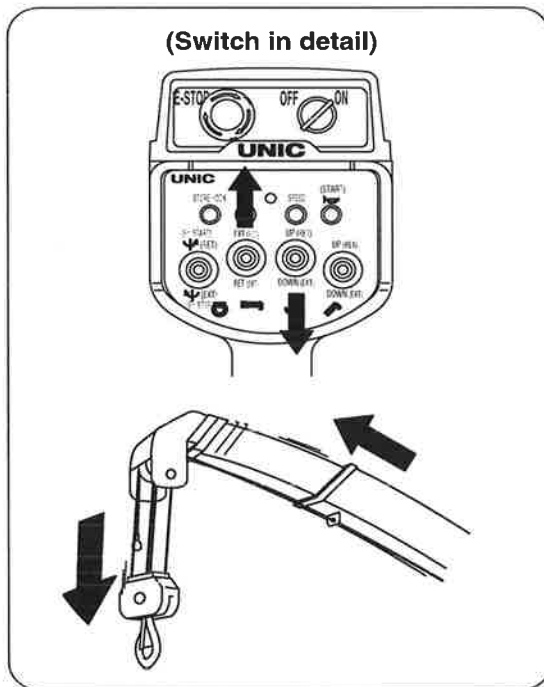

Pull the speed lever with the “Hook Up/Down” switch thrown to “Down” and the “Boom Ext/Ret” switch put to “Ext”.

The hook lowers and the boom starts to extend.

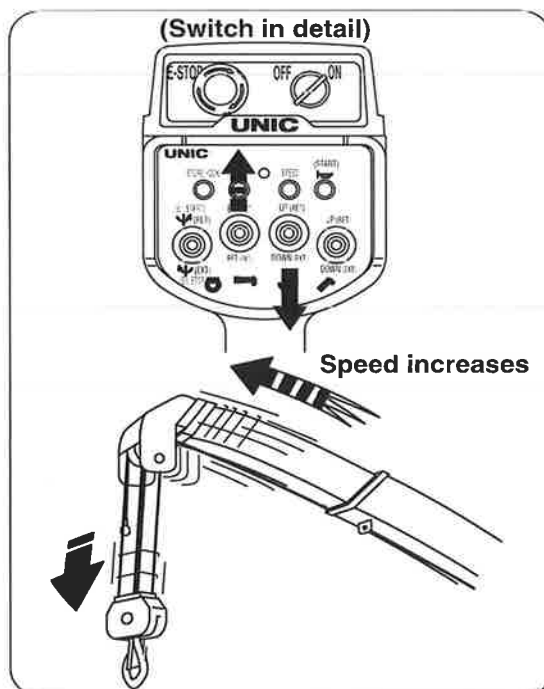

● To increase extending speed of boom
Click (operate it quickly in order of ON→OFF→ON) the “Boom Ext/Ret” switch to “Ext” side.

This allows extending speed of boom to become faster than that of hook down.

The more number of times the switch has been clicked toward “Ext”, the faster the boom extension becomes as oppose to that of hook down.

U-WAVE, Radio remote control device

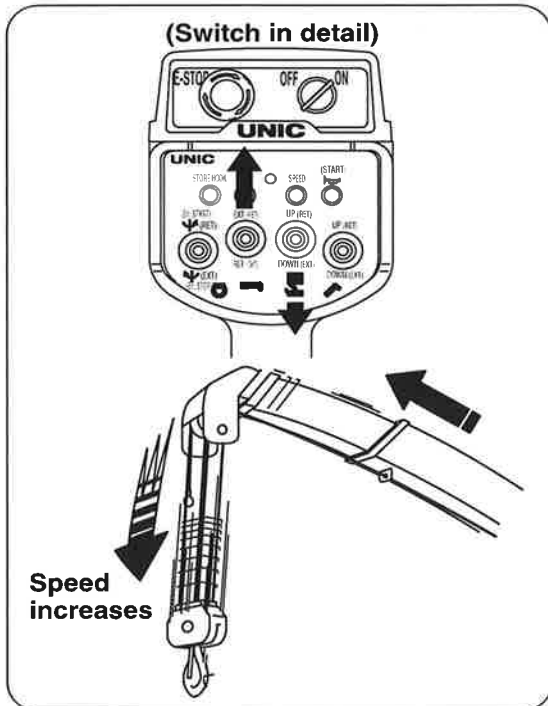

● **To increase winding Down speed of hook**

Click the “Hook Up/Down” switch to ”Down” side.

This allows the speed of hook down to become faster than that of boom extension.

The more number of times the switch has been clicked for “Down”, the faster the speed of winding Down hook becomes as opposed to that of boom extension.

● **Remarks**

- **Repeated clicks allow the other operation not to function in the end.**
If this happened, release all the “selector switches” once, or click the “selector switch” for which operation is inactivated.
- **When one of “selector switches” is released during the clicking operation, speed of crane under operation may become faster.**
- **The clicking function is possible only when in 2-interlocking operation.**
It will not be applied to operation such as of 3-interlocking and 4-interlocking.

U-WAVE, Radio remote control device

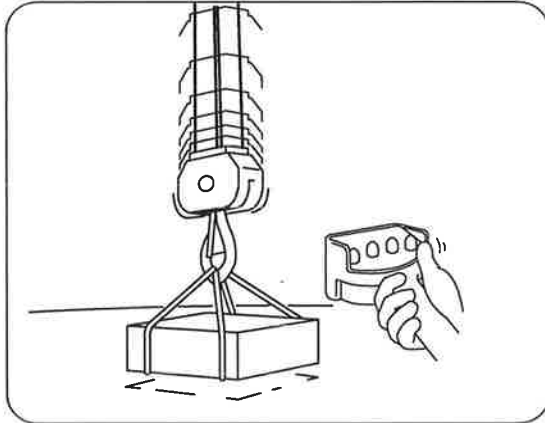

5. Shock-less function

The system equips a “shock-less” function allowing the crane to stop gently even when the crane has been made an abrupt stop by radio control transmitter.

Since the crane will not make an abrupt stop against a sharp operation, it eases shock to the crane and/or to the mounted vehicle, and it is also effective to prevent the wire rope from jumping up and a lifted cargo from swinging when the hook has stopped winding-up.

⚠ CAUTION

★ Pay attention that the crane makes a slight movement due to shock-less function after the radio control operation has been stopped abruptly.

● **Remarks**

When making the crane a sudden stop:

If the crane has to be made a sudden stop, actuate the “Selector switch” controlling opposite function while the shock-less is functioning.

(Do not pull the speed lever in this case.)

Otherwise, the shock-less function is released to allow the crane to make a sudden stop.

When canceling the shock-less function:

If the shock-less function is unnecessary, it can be activated/inactivated by the radio control transmitter.



U-WAVE, Radio remote control device

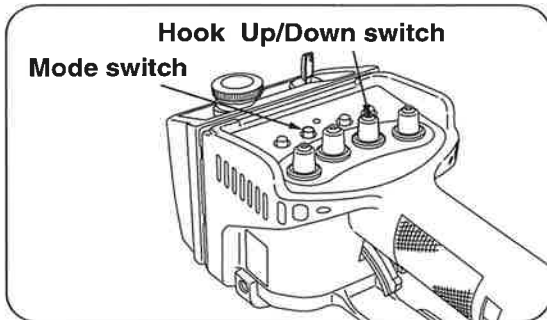

In order to inactivate the shock-less function, throw the “Hook Up/Down” switch to “Down” with the “Mode switch” depressed. The shock-less will not be functioning.

In order to activate the shock-less function, throw the “Hook Up/Down” switch to “Up” with the “Mode switch” depressed. The shock-less starts functioning.

When the shock-less function is active and the “Mode indicator lamp” shows any of [00] through [07], switching it to be inactive allows the figure indicated on the left to change to [-]. Switching the shock-less function to be active again allows the mark [-] indicated on the left to change to [0].

| Mode display | |
|----------------------------------|------------------------------------|
| When shock-less function active: | When shock-less function inactive: |
| 00 | -0 |
| 01 | -1 |
| 02 | -2 |
| 03 | -3 |
| 04 | -4 |
| 05 | -5 |
| 06 | -6 |
| 07 | -7 |

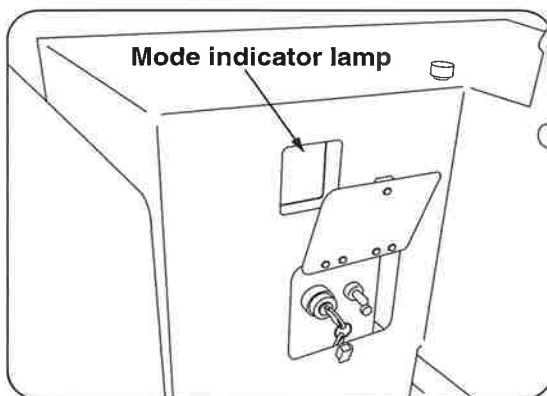

CAUTION

★ Be sure to check if the mode indicator changes accordingly after the shock-less function has been switched.

●Remarks

When the mode indicator shows [10] (over-wound condition), no change happens even after the shock-less function has been switched.

When checking condition of the shock-less function, remove the over-wound condition by operation of lowering hook or retracting boom.

Setting of shock-less function is to be memorized after power to the crane has been turned OFF.

U-WAVE, Radio remote control device

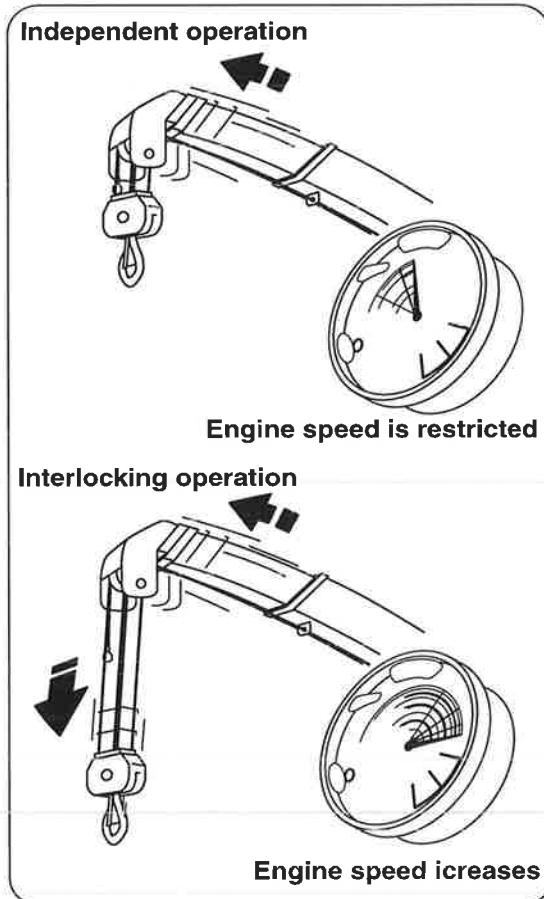

6. Engine speed control function

The system equips a function controlling the engine running at a suitable speed according to operating condition of the crane.

The function helps save energy because it can ease temperature rise of hydraulic oil and restrict the unnecessary increase of engine speed by controlling the engine to run at an appropriate speed.

- On independent crane operation, it allows the engine speed not to be increased unnecessarily while the crane is operating functions such as lowering boom, retracting boom, slew C.C.W./C.W., and retracting outriggers.
- The engine speed increases when the crane operation has been switched from independent to interlocking. (But no change in maximum engine speed.)
- The engine runs at a medium speed while the outriggers are being extended and retracted.
- When swinging the crane on independent operation by controlling manual lever, swinging speed may become faster when the independent operation is switched to interlocking operation by controlling other one of levers.
This is not a fault.

U-WAVE, Radio remote control device

◆3. How to store hook

⚠ WARNING



★ Since releasing the hook from its stored position allows it to swing, it may cause an accident if a person stands under the hook.

In addition, excessive pulling of the “Speed lever” increases the hook to swing that is dangerous so that do not pull the lever extremely.

★ It is strictly prohibited to operate the crane with the “Storing hook” as this is very dangerous.

★ Retract the boom fully and lower it to its extreme to store it.

★ Do not operate the “Storing hook” with any one of control levers at the same time.

This may cause an incorrect action and/or a breakdown of the crane.

★ Pay attention that the manual control lever for “Hook Up/Down” moves “Up” side when retracting the hook.

U-WAVE, Radio remote control device

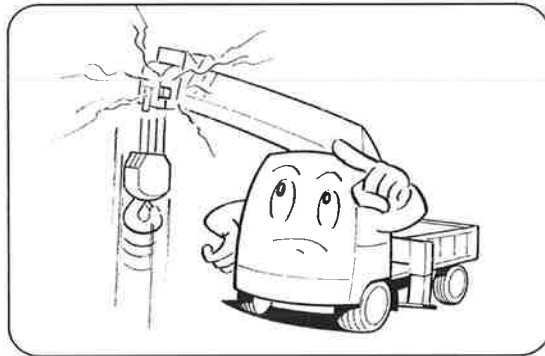
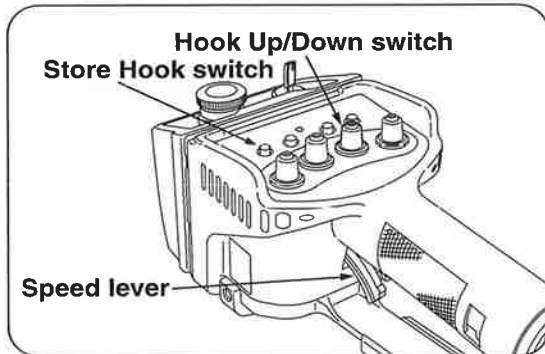

- (1) Wind up the hook with the “Hook Up/Down” of selector switches.

The hook stops being wound-up automatically when it hits against the weight for over-winding alarm.

- When it stops being wound-up, following voice message, “**Beep, Stop winch up, Stop winch up, Beep, Beep**” is issued.

The last part of voice message, “**Beep, Beep**”, stops sounding when the operation concerned has been stopped.

- (2) Depress the “Store hook” switch after the hook is at a standstill.

- Following voice message, “**Ping-pong, Secure lifting hook, Secure lifting hook**” is issued.

- (3) When pulling the “Speed lever” with the “Store hook” switch depressed, the hook starts being wound up slowly.

The “Mode indicator lamp” indicates [!] while the hook is being stored.

CAUTION

★ Storing the hook while it is swinging may cause damage to the boom, to the hook itself, and to the wire rope.



U-WAVE, Radio remote control device

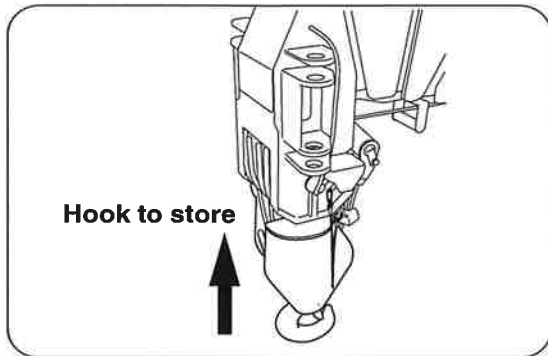

- (4) The hook hits against the guide on the boom top to be stored in position
Storing hook operation stops when the “Speed lever” is returned and then the “Store hook” switch is returned.

● **Remarks**

The engine is still running at a low speed (idling) while the hook is being stored.

⚠ CAUTION

★ If the hook is off the boom top while storing hook, lower the hook once, then carry out storing hook operation again.

U-WAVE, Radio remote control device

◆4. How to operate outriggers

Crane operation mode and outrigger operation mode can also be switched from radio control transmitter..

1. Preparation before operation

When the selector switch is thrown to “Boom down” with the “Mode switch” depressed, the outrigger mode indicator lamp located on top part of control panel lights and the mode is switched to outrigger operation mode.

Indication of “Mode indicator lamp” changes to [04] and [05], and voice message, “Change control mode”, is issued.

●Remarks

Turning OFF switch on the buzzer to stop the alarm sound.

If alarm sound of buzzer is to be avoided such as in working at night, turn it OFF to stop the buzzer.

Turn it ON when in normal crane operation.

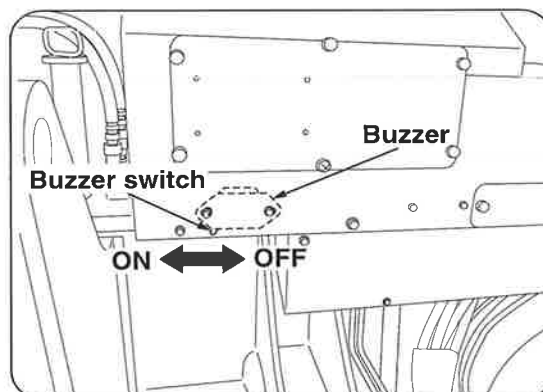
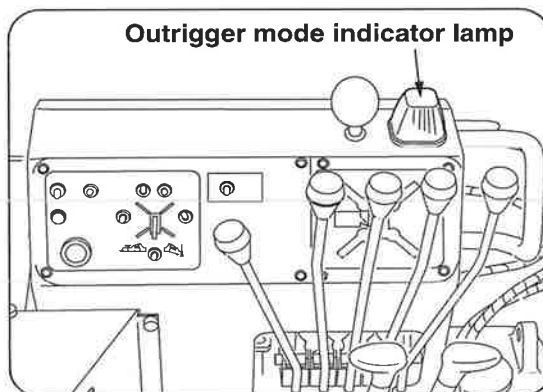
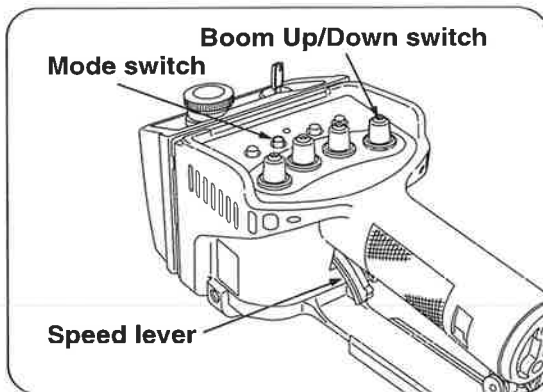

U-WAVE, Radio remote control device

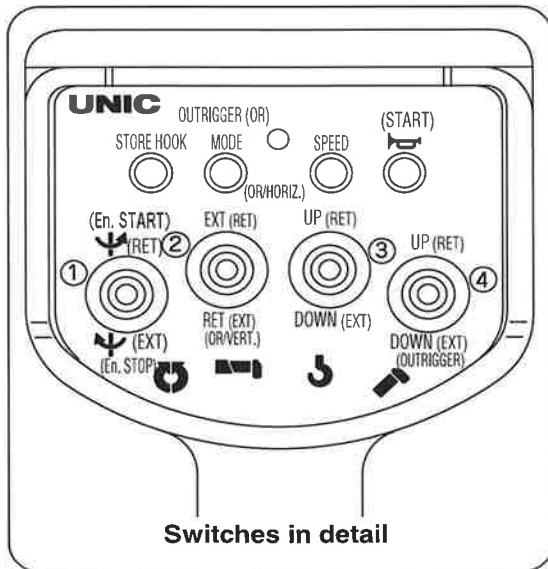
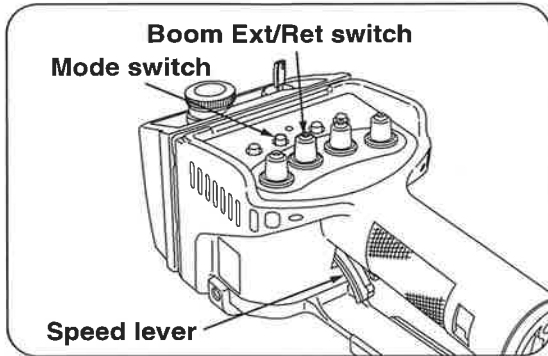

2. Operation

Extension/retraction control of vertical cylinder and of inner box can also be switched from radio control transmitter.

- ① When the selector switch is thrown to “Boom extend” with the “Mode switch” depressed, voice message, “**Change control mode, Change control mode**”, is issued and it allows switching to extension/retraction control of inner box.
- ② Throw the “Selector switch” corresponding to the outrigger number requiring control to the desired operation side. Then pull the “Speed lever” slowly while keeping the “Selector switch” thrown to the desired operation. As the “Speed lever” is pulled slowly, the inner box starts to be operated gradually with the engine running at a low (idling) speed, and pulling it further allows operating speed of the outrigger becomes faster as the engine speed is increased.
- ③ When the selector switch is thrown to “Boom retract” with the “Mode switch” depressed, voice message, “**Change control mode, Change control mode**”, is issued and it allows switching to extension/retraction control of vertical cylinder.
- ④ Throw the “Selector switch” corresponding to the outrigger number requiring control to the desired operation side. Then pull the “Speed lever” slowly while keeping the “Selector switch” thrown to the desired operation. As the “Speed lever” is pulled slowly, the vertical cylinder starts to be operated gradually with the engine running at a low (idling) speed, and pulling it further allows operating speed of the vertical cylinder becomes faster as the engine speed is increased.



U-WAVE, Radio remote control device

To extend

Turn the switch to "Extend" to pull the "Speed lever".

To retract

Turn the switch to "Retract" to pull the "Speed lever".

To stop

Return the "Selector switch" after the "Speed lever" has been returned slowly.

●Remarks

When the "Crane/outrigger operation mode selector switch" is turned to "Outrigger" (outrigger mode indicator lamp is being lit), normal crane operation of "Boom Up/Down", "Hook Up/Down", "Telescoping boom", "Slewing C.C.W./C.W.", and "Storing hook" to be impossible both in radio control transmitter and in manual control lever.

- ⑤ When the selector switch is thrown to "Boom Up" with the "Mode switch" depressed, voice message, "Change control mode", is issued and the mode is switched to crane operation mode when the outrigger mode indicator lamp located on top part of control panel goes off.

CAUTION

★When it has been switched from the crane mode, it is in vertical cylinder Extension/Retraction mode".

If extension or retraction of inner box is required, switch it to operation of extension or retraction of inner box.

★If it has been selected to the mode (operation) to which is going to be selected, voice message will not be issued.

U-WAVE, Radio remote control device

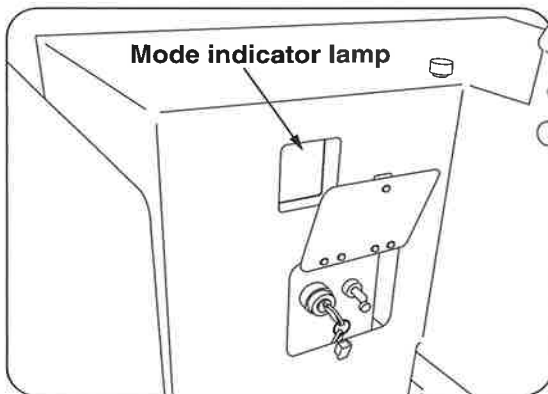
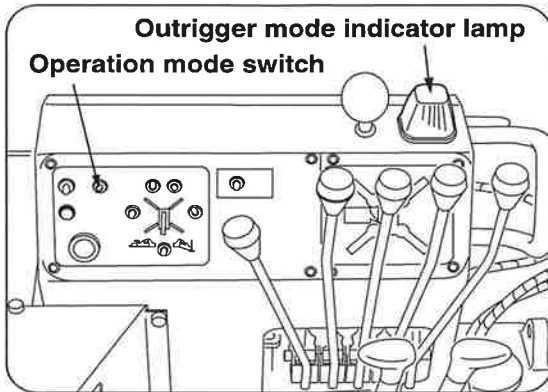

3. Closing operation

When extending/retracting operation of outrigger through the radio control transmitter has been over, be sure to turn the “Crane/outrigger operation mode selector switch” to “Crane”.

The outrigger mode indicator lamp goes off and the buzzer stop sounding.

Indication of the “Mode indicator lamp” changes to either one of [00], [0 t], [06], or [0 7], and voice message, “Change control mode”, is issued.

(Refer to section 18. 1 “Mode indicator lamp” (on page 18-1) for mode indication in detail.

! CAUTION

★Take special care that your foot will not be stamped by outrigger while extending outriggers.

★Be sure to secure the hook in place while outriggers are being operated.

U-WAVE, Radio remote control device

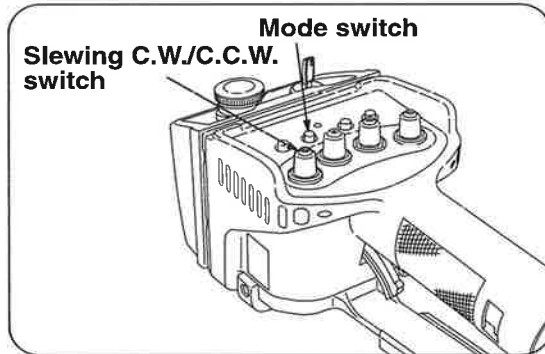

◆5. Starting/Stopping engine

The engine can be started and stopped from the radio control transmitter.

- ① When the engine key is turned ON, turning the selector switch to "Slewing C.C.W." with the "Mode switch" being depressed allows the engine to start.
- ② Turning the selector switch to "Slewing C.W." with the "Mode switch" being depressed allows the engine to stop.

⚠ CAUTION

★When the engine is to be stopped for a long period of time, be sure to turn OFF the engine key on the side of crane.

If the engine is being stopped by radio control transmitter for a long time during which power to transmitter is turned ON, shortening the life of batteries results.

★The radio control system carries out system diagnosis automatically every time when power is turned ON.

Do not operate the crane while the system diagnosis is being carried out.

(Do not touch any one of switches and levers during this period.)

If the crane is operated during system diagnosis, voice message, "Beep, Service remote control, Service remote control", sounds and the crane is turned into inoperable conditions.

If this happened, depress the reset switch of the control box to carry out system diagnosis again.

★If the voice message, "Beep, Service remote control, Service remote control", is issued when turning ON the power despite the fact that the crane has not been operated, ask a UNIC authorized service shop for repair as failure in the radio control system is suspected.

U-WAVE, Radio remote control device

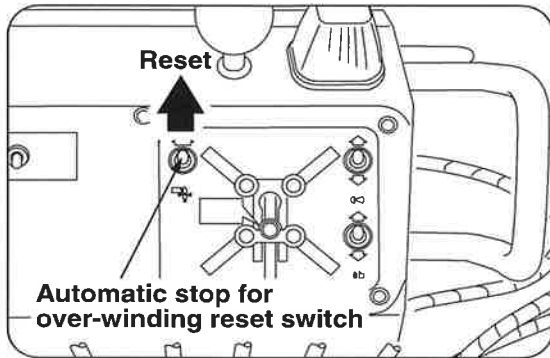

◆6. How to reset when in trouble with automatic stop for over-winding

In case where operation of “Hook Up”, “Boom Extend”, and “Boom Up” becomes impossible due to trouble with automatic stop for over-winding, operate it with the automatic stop switch for over-winding on the crane side put to “Reset”.

This allows operation of “Hook Up”, “Boom Extend”, and “Boom Up” to be possible.

◆7. How to operate when engine speed becomes unstable due to low temperature

When in winter season or when temperature is too low, the engine speed may become unstable as viscosity of hydraulic oil increases.

In this case, switch the system to “low temperature operation mode” to allow the engine speed to be stable.

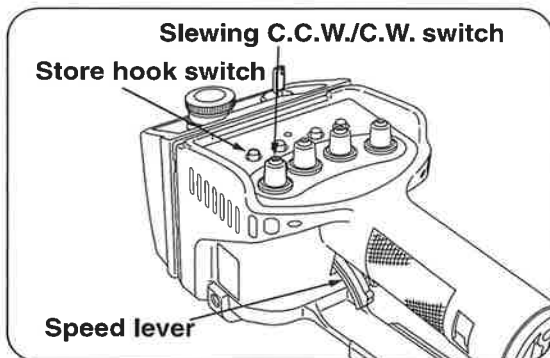

1. Switching to low temperature operation mode

Depress the “Store hook” switch with the “Slew C.C.W./C.W.” switch turned to “C.C.W.”.

Indication of the “Mode indicator lamp” changes to [05], and voice message, “Ping-pong, Change control mode, Change control mode”, is issued.

(Indication will not change if the “Mode indicator lamp” is showing [04], [05], or [10].)

●Remarks

When switching it to low temperature operation mode, operation of the “Store hook” switch before the “Slew C.C.W./C.W.” selector switch has been actuated may allow voice message, “Ping-pong, Secure lifting hook, Secure lifting hook”, to be issued.



U-WAVE, Radio remote control device

2. Resetting low temperature operation mode

Depress the “Store hook” switch with the “Slew C.C.W./C.W.” switch turned to “C.W.”.
Indication of “Mode indicator lamp” changes to [00] and voice message “**Ping-pong, Change control mode, Change control mode**”, is issued.
(Indication will not change if the “Mode indicator” is showing [04], [05], or [[10]].)

In addition, the low temperature operation mode is to be reset automatically, even when operation illustrated above has not been carried out, after approx. 10 minutes from the time when it has been switched to the “Low temperature operation mode”.

The voice message “**Ping-pong, Change control mode, Change control mode**”, is issued at this time.

●Remarks

Response of the crane functions becomes slower when operated on low temperature operation mode.

In normal case, operate the crane after warming-up for a while to raise temperature of hydraulic oil.

Under extreme low temperature, crane operation may still be unstable even after the system has been switched to the “Low temperature operation mode”.

In this case take measures such as by carrying out warm-up operation to raise temperature of hydraulic oil or by using hydraulic oil suitable for extreme low temperature.

⚠ CAUTION

★If viscosity of hydraulic oil is too high at a low temperature, excessive load will be imposed on hydraulic pumps which may cause damage to them.

In order to avoid this, be sure to carry out warming-up to raise temperature of hydraulic oil to an appropriate temperature to operate the crane.

◆8. Closing crane operation

After completion of the crane work, turn OFF the starter switch to shut off power to the crane after the boom, the hook, and the outriggers have been stored in their respective positions.

U-WAVE, Radio remote control device

7 How to replace batteries of transmitter

◆1. How to replace batteries of transmitter

! CAUTION

★When the power lamp of transmitter starts blinking, replace the batteries as early as possible. Leaving them as they were may cause the liquid of batteries to be leaked out.

★In case where battery liquid is leaked out, wipe it off the battery holder and the battery case thoroughly then put new batteries in it.

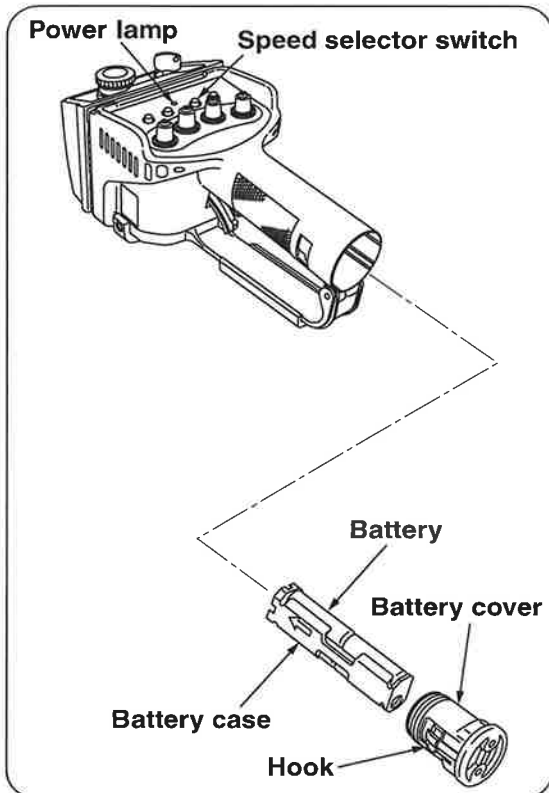

●Check how the “Power lamp” lights with the “Speed selector switch” on the transmitter depressed.

- ① Continuous lighting: Radio control transmitter can be used.
- ② Blinking in low frequency (a flash every second): It allows the radio control transmitter to be used for about 1 hour after the blinking has started. Replace the batteries as early as possible as they are close to running out.
- ③ Blinking in high frequency (a flash every 0.1 second): The radio control transmitter can not be used further as the batteries have been running out.
- ④ No lighting: The radio control transmitter can not be used as the batteries have completely run out.

●If the “Power lamp” blinks slow as in the state of ② above, following voice message, “Ping-pong, Low transmitter battery, Low transmitter battery”, is issued. The trouble lamp on the receiver blinks in red, and the “Mode indicator lamp” indicates [99] in blinking.



U-WAVE, Radio remote control device

◆2. Battery to be employed

a size AAA battery: 4 pieces

Use alkaline-type battery.

(Manganese-type battery has a short service life.)

●Remarks

About the use of rechargeable batteries

Although UNIC recommends the use of alkaline type battery in the radio control device, other rechargeable batteries such as nickel-hydrogen type and nickel-cadmium type may also be used.

Pay attention to the following when a rechargeable battery is used:

- Message suggesting replacement of battery may not be issued.
Be sure to prepare alkaline-type batteries when operating the crane through radio remote control device because rechargeable batteries tend to become inoperable suddenly.
- In some cases, service life of rechargeable battery may become shorter than that of alkaline battery in accordance with the capacity.
- There is a disadvantage such as memory effect comparing with alkaline-type battery.



CAUTION

★Do not mix up batteries of old and new, of different manufacturers, or of different types.

U-WAVE, Radio remote control device

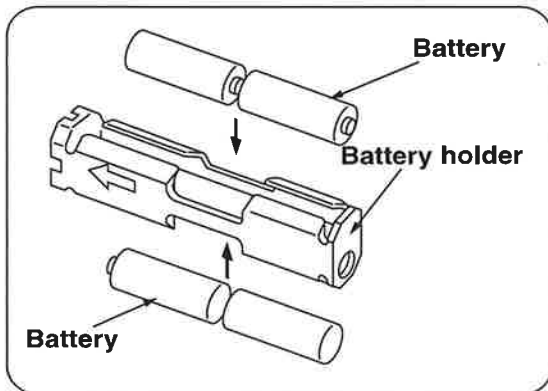

◆3. How to replace batteries

- (1) Turn OFF power to the crane. (Turn OFF the starter switch.).
- (2) Pull out the battery cover with the hook on the cover pushed in.
- (3) Replace old batteries in the battery holder with new ones.

⚠ CAUTION

★Pay attention to polarity of batteries.

(Put them as indicated on the battery holder

★Do not connect between terminals of (+) and (-) directly with a metal piece.

- (4) Insert the battery holder into the transmitter grip to tighten up the battery cover securely.

⚠ CAUTION

★Take care that a drop of water will not enter inside of the grip.

- (5) Depress the “Speed selector switch” to check that the “Power lamp” lights.

●Remarks

Unless to the power to crane is turned OFF once when replacing batteries, blinking indication of [99] on the mode indicator lamp will not goes off even after batteries have been replaced.



U-WAVE, Radio remote control device

8 Daily checks, trouble inspection

◆1. Daily checks

For cranes with radio remote control device, you are requested to inspect your crane for following items as well as carry out daily checks on your crane (read operator's manual of UNIC crane concerned for detail).

Check that;

1. Each enclosure of transmitter, receiver, and control box has not been damaged.
If the enclosure has been damaged, repair it immediately because moisture and/or dust entered through the break may cause a failure to electronic parts inside and cause incorrect operation of the crane concerned.
2. The stay on the transmitter has not been broken or deformed.
The transmitting antenna is built in the stay.
If break or remarkable deformation is found in the stay, replace or repair it as soon as possible because it may cause radio interference.
3. Switches and control levers on the radio control transmitter make a smooth operation.
Using the remote control transmitter with dust, dirt, and mud being stuck on may lead to failure especially in operation of switches and/or control levers.
Wipe them off with a piece of cloth after use.
If any of the selector switches fails to function correctly due to contamination, ask a UNIC authorized service shop for cleaning.

⚠ CAUTION

★Never try disassembly or alteration of the transmitter, the receiver, and the control box.

★Electric system is very sensitive to moisture.
Do not wash the transmitter, the receiver, and the control box with water directly.

U-WAVE, Radio remote control device

◆2. Check lamps (Radio control receiver)

Check lamps are mounted on the radio receiver, and they light as follows when it is in normal operating condition:

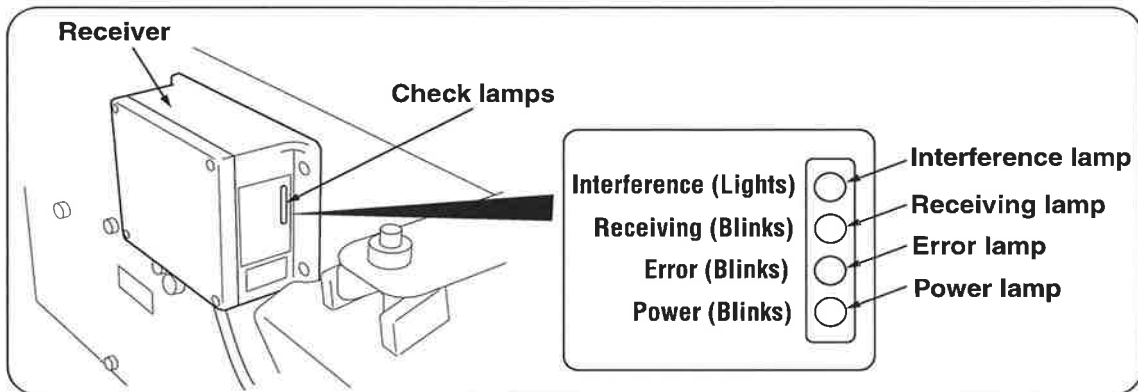

● Power lamp

When energizing the crane by turning ON the starter switch, it blinks in green.

● Receiving lamp

When the receiver is received radio wave transmitted from the transmitter correctly, it blinks in green.

● Interference lamp

If it lights in red when power to the transmitter is turned OFF, it indicates that the receiver is receiving radio wave from outside.

If it lights in red when power to the transmitter is turned OFF, response time during radio control operation may become longer to a certain extent.

When radio control operation is initiated from the state where the power to transmitter is turned OFF, the “interference lamp” may light for a moment but it is not a fault.

● Error lamp

It blinks in red when something is wrong with the radio control transmitter/receiver.

It also blinks in red when batteries in the transmitter have been run out.



U-WAVE, Radio remote control device

◆3. Trouble inspection

If a trouble is found in the radio remote control device, check the following then contact the nearest UNIC authorized service shop.

Check if:

- ① Crane is controlled by manual levers.
- ② The “Power lamp” on the transmitter lights. If it blinks or does not light, replace the batteries in the transmitter.
- ③ Switches and control levers on the transmitter make a correct operation.
- ④ The stay on the transmitter (antenna is built in) has not been broken or deformed.
- ⑤ The “Mode indicator lamp” in the control box lights and the “Power lamp” on the receiver blinks in green when power to the control box is turned ON.
If the “Mode indicator lamp” blinks, refer to section ”18. **1** Mode indicator” (on page18-1).

If the “Error lamp” on the receiver blinks in red, turn OFF the power once and turn it ON again (turn ON the starter switch again).

If blinking of “Error lamp” persists, repair is needed as the radio remote control device is in failure.

U-WAVE, Radio remote control device

◆4. How to make an emergency stop

In case of emergency such as that the crane does not stop operation or the engine will not return to idling speed even if no crane operation has been made, depress the “EMERGENCY” switch on the switch panel.

This makes the crane and the engine to stop operation forcibly.

! WARNING

★When releasing the emergency stop switch, release it while no crane operation is being carried out.

Releasing the emergency stop switch while operating the crane allows the crane to make an abrupt movement that is very dangerous.

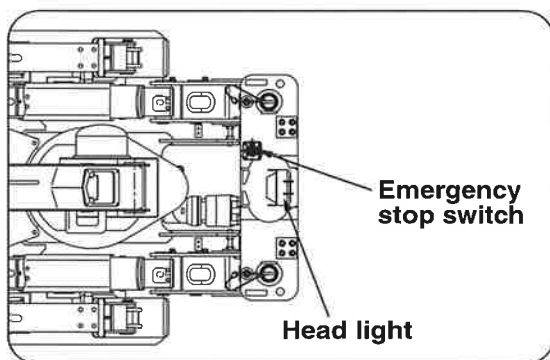
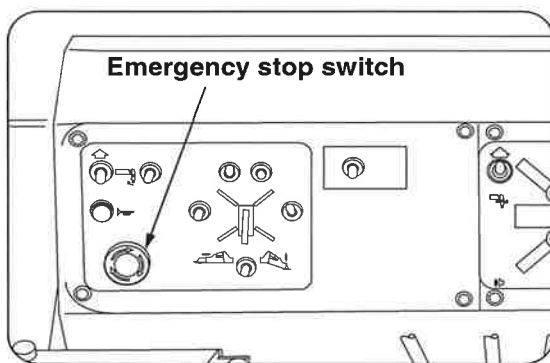

●How to make an emergency stop for the crane and reset it

Depress the “EMERGENCY” stop switches on the switch panel of crane body and near head light.

The switch is held pushed in allowing the engine to stop operation.

When the switch is held pushed in, the engine cannot be re-started.

Rotate the emergency stop switch clockwise in arrow direction to return to its original state to release the switch.

●Remarks

When the emergency stop is reset by turning the “EMERGENCY” stop switch clockwise after the crane has been stopped by depression of “EMERGENCY” stop switch, the engine speed may increase in a moment which is not abnormal.

When the crane is operated with the “EMERGENCY” stop switch held pushed in, voice message, “Beep. Service remote control, Service remote control” may be issued or the mode indicator lamp may show incorrect indication.

U-WAVE, Radio remote control device

◆5. Operation in an emergency

If the crane fails to be operated either by radio remote control or by manual control, operate the crane by taking procedures as follows:

Procedure 1

- ① Disconnect the power connector [BATTERY MAIN] located under the control valve.

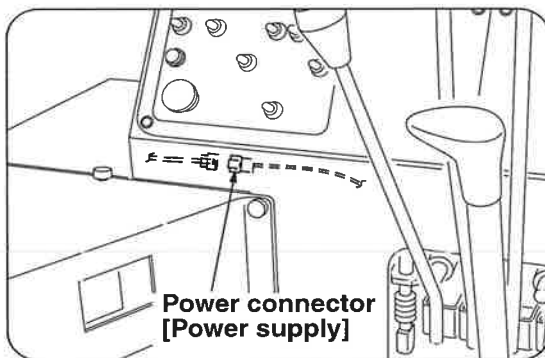

- ② Remove the lock pin attached to the emergency screw and gently turn the emergency screw clockwise until tight. (Pay attention that the screw may break if it is tightened with an excessive force.)
- ③ Check that all manual control levers are at their neutral positions. If a lever has been caught in halfway, return it to its neutral position.
- ④ Loosen the hexagon nut attached to the lower part of the control valve and then tighten the locked set bolt until tight. This allows the crane to be operated.

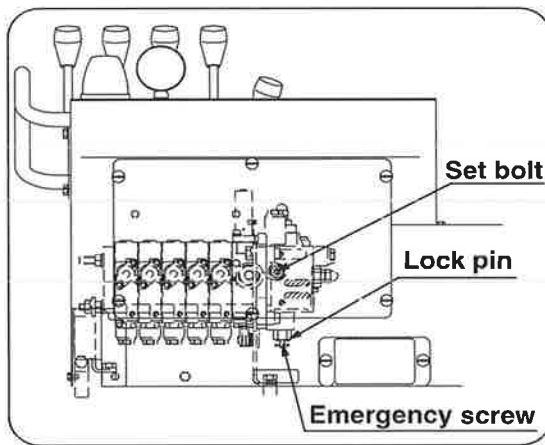

⚠ CAUTION

★Be sure to tighten up the set bolt after the emergency screw has been tightened.

If the set bolt has been tightened up without tightening the emergency screw, the crane may make an abrupt movement.

★In this situation, safety devices such as engine speed control, voice message, and automatic stop are not functioning so that careful operation is needed.

★Since this is a measure when in an emergency, be sure to repair the crane at an authorized UNIC service shop after it has been stored.



U-WAVE, Radio remote control device

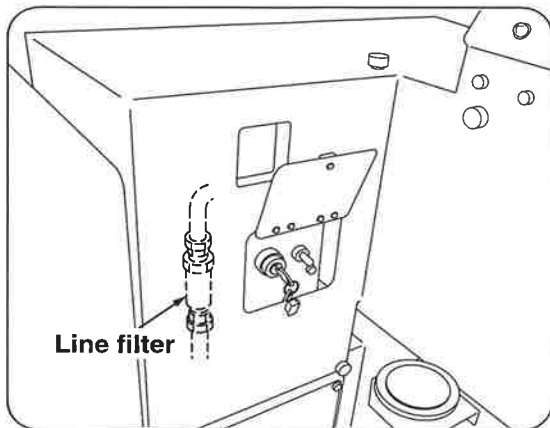

◆6. Replacement of line filter element

Replace the element inside of line filter after 1 year from the start of operation.

Be sure also to replace the element when the hydraulic pump is replaced and replace it after 1 year from the start of operation of the pump.



13. MAINTENANCE AND INSPECTION OF CARRIER

! WARNING

★ **Caution signboard**

Be sure to hang a “caution signboard” such as on control levers while either maintenance or inspection is being carried out, and do not try operating the crane.

★ **Be sure to replace consumable items according to the replacement criteria.**

Failure to observe the replacement as specified may cause a breakdown and warranty will not be given even if it is within the period to be applied.

★ **When a part needs to be replaced or anything abnormal is found, contact a UNIC service shop for consultation or for inspection or ask repair as soon as possible.**



MAINTENANCE AND INSPECTION OF CARRIER

1 Inspection before operation

! WARNING

- ★ Be sure to stop the engine, and store the boom and the outriggers before carrying out maintenance and inspection.
- ★ A fire source such as smoking cigarette in mouth is strictly prohibited.
- ★ Do not start maintenance and inspection immediately after the engine has been stopped.
Carry it out after the engine and the heated parts have been cooled down.

In order to secure safety in inspection work and to improve working efficiency, be sure to inspect each part of the carrier according to the table as follows:

| Device | Servicing item | Device | Servicing item |
|--------|--|-------------------------------------|---------------------------------------|
| Engine | Remaining fuel quantity / Draining water Engine oil quantity / Filling up Cooling water quantity / Filling up Fan belt tension / Adjustment Battery electrolytic solution level check Unusual vibration, Noise Loose bolt, Broken bolt | Hydraulic oil tank | Oil leakage, Oil quantity, Filling up |
| | | Interlock for crane-crawl operation | Function |
| | | Crawling lever | Slack, Travel |
| | | Wheel sprocket | Loose bolt |
| | | Rubber crawler | Crack, Damage, Tension |
| | | Frame | Bend, Crack, Deformation |
| | | Truck roller | Loose nut, Oil leakage |

! CAUTION

- ★ Keep the crawler crane in good condition so that it will be always ready for normal operation.

MAINTENANCE AND INSPECTION OF CARRIER

◆1. Check for remaining fuel quantity
/ Draining water

! WARNING

★Fuel (diesel fuel oil) is highly inflammable.
Do not smoke and bring a fire source close to the fuel when refueling and draining sediment.

★Wipe up spilled fuel thoroughly after refueling as it may cause the fire.

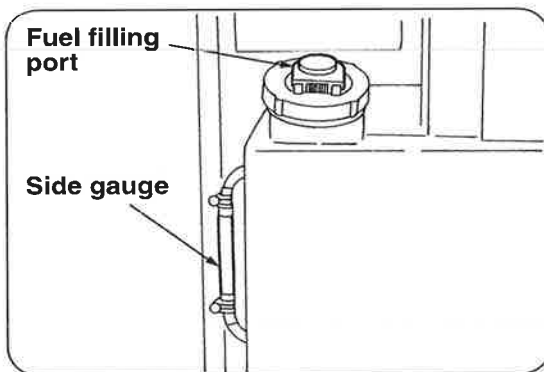

- Insert the key into the starter switch and turn it to “START” position to bleed the air out of the fuel system for a few seconds then the engine starts.
Fuel filling port is located on the right side at the rear of the crane.
- Check the side gauge that fuel is filled enough before starting inspection.

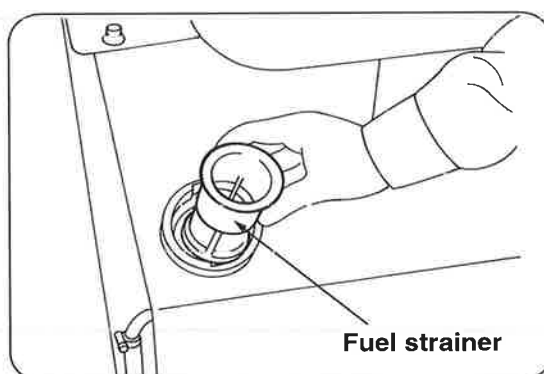

- When refueling, prevent dirt and dust from entering the filling port and be sure to put the strainer of fuel tank in the port.
- Lock the cap after the refuel.
Fill up the tank after completion of carrier operation.
Fuel tank capacity : 74 liters

MAINTENANCE AND INSPECTION OF CARRIER

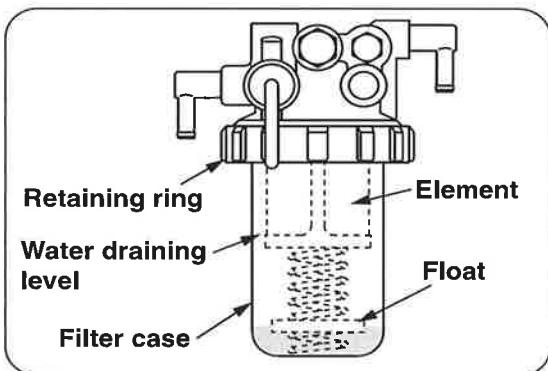
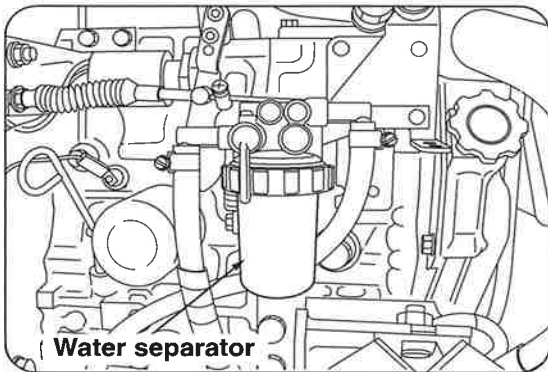

- Moisture mixed with the fuel can be removed by the water separator.

- **Draining moisture and sediment by water separator**

Water separator is built in the fuel filter and functions to separate moisture from the water mixed fuel to avoid trouble caused by water.

Check it everyday and remove the retaining ring to drain the accumulated water if the “float” reaches the element inside of the case.

MAINTENANCE AND INSPECTION OF CARRIER

◆2. Check for engine oil quantity / Filling up

! WARNING

★Wipe up spilled oil thoroughly after filling it up as it may cause the fire.

! CAUTION

★Replace engine oil and fuel filter element after 100 hours (1 month) of operation, then every 250-hour operation (3 months) thereafter.

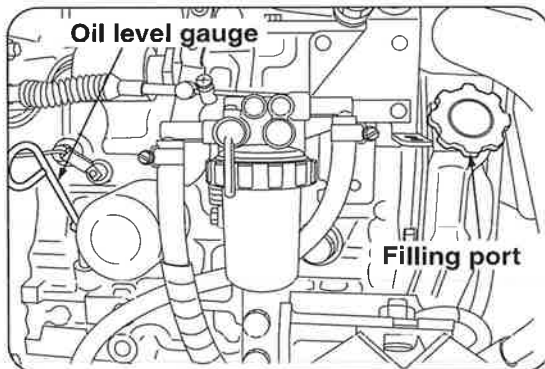

Check engine oil quantity before starting the engine with the crawler crane parked on a flat ground.

If the engine has been started, check the oil level after at least more than 5 minutes when the engine had been stopped.

- Extract the oil level gauge and wipe it off with a piece of clean rag. Insert the gauge again slowly then extract it to check the level wet with oil. (Check the oil for contamination and viscosity at the same time.)

- If oil level is found too low, supply it from the filling port.

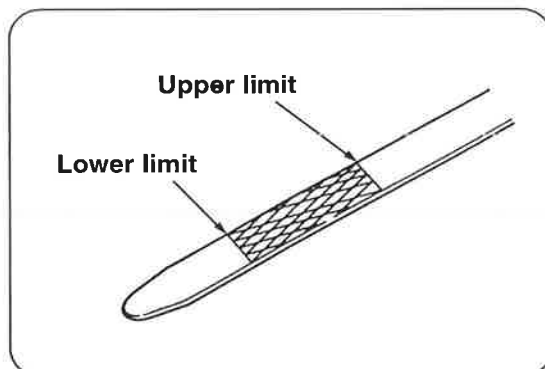

MAINTENANCE AND INSPECTION OF CARRIER

◆3. Check for cooling water quantity / Filling up

! WARNING

★In normal case, do not open the radiator cap. Removal of the cap with the engine overheated allows steam and heated water inside to blow out which may cause a skin burn.

★Check cooling water quantity at the reservoir tank while the engine is cold.

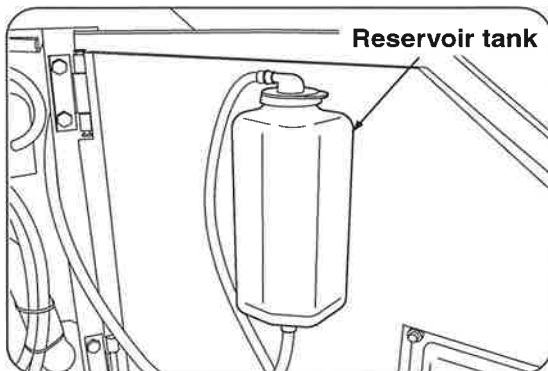

A proper quantity of cooling water is somewhere between level marks of “FULL” and “LOW”.

If the water level is at “LOW” mark or below the mark, supply water to the level “FULL”.

If no cooling water is remained in the reservoir tank, remove the radiator cap to fill it up to the neck of radiator.

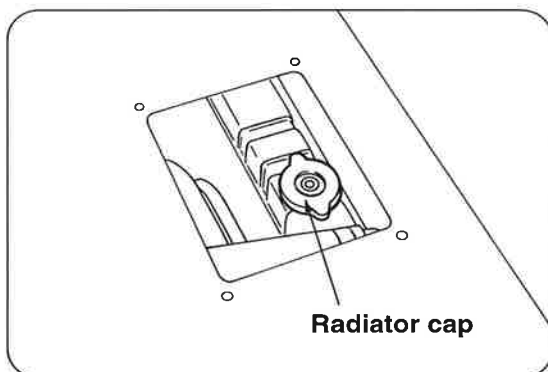

MAINTENANCE AND INSPECTION OF CARRIER

◆4. Check for fan belt tension / Adjustment

! WARNING

★Do not make an inspection and an adjustment of fan belt while engine is running.

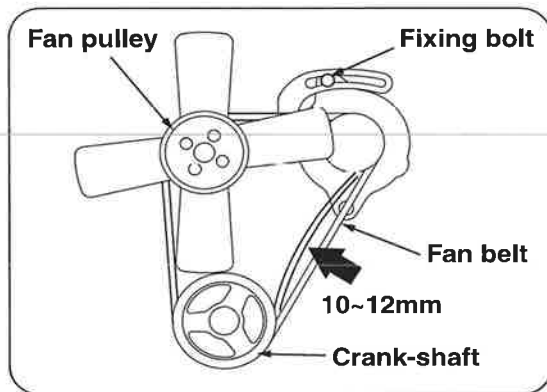

- Check the fan belt for tension and for damage.
- A proper tension is 10~12mm in sinking deflection with the belt pushed with your finger (approx. 10kg) at the center between the alternator pulley and the crank-shaft.
- When make an adjustment unfasten the fixing bolt for alternator and shift the alternator so that a proper belt tension can be obtained.

MAINTENANCE AND INSPECTION OF CARRIER

◆5. Check for battery electrolytic solution level / Filling up

⚠ WARNING

★Gas evaporated from the battery solution is inflammable. Do not bring a fire source close to the battery during a battery maintenance.

And, be sure to disconnect the negative (-) side of battery cord.

★Battery electrolytic solution contains sulfuric acid so that you may be blinded or burned by the solution when your eye, skin, or clothes was stained with the solution.

Wear safety goggles and rubber gloves as a protective measures when working at battery.

If the solution stuck to your skin or clothes, wash it away with plenty of water immediately.

In case where it entered into your eye accidentally, see a doctor for treatment.

★When the crane will not be operated for a long period of time such as in being stored, charge the battery as follows:

Warm season : Once a month

Cold season : Once every 2nd month

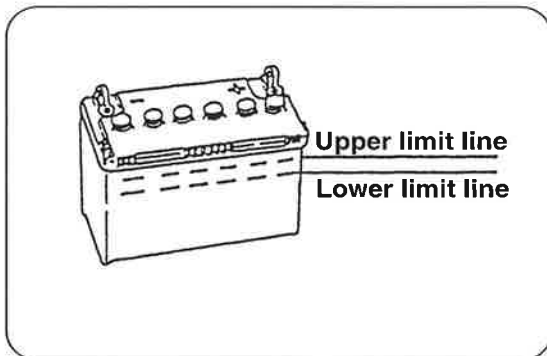

- Check that the battery solution level is somewhere between the upper and the lower limit lines with the battery placed level.
- If solution level is found below the lower limit line, remove the cap to fill it up with distilled water (It is available at a gas station.)
Tighten the caps securely after the water has been filled.
- Pay attention that the crane body may be eroded by the battery solution due to leakage during operation if solution level exceeds beyond the upper limit line.

MAINTENANCE AND INSPECTION OF CARRIER

◆6. Check hydraulic oil tank for oil level / Filling up

⚠ WARNING

★ Since temperature on the hydraulic oil tank surface is too high immediately after operation, remove the cap of the filling port after the temperature has gone down.

⚠ CAUTION

★ Replace hydraulic oil after 3 months after the start of carrier operation, then once a year thereafter.

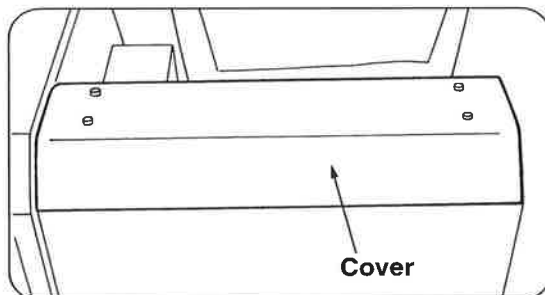
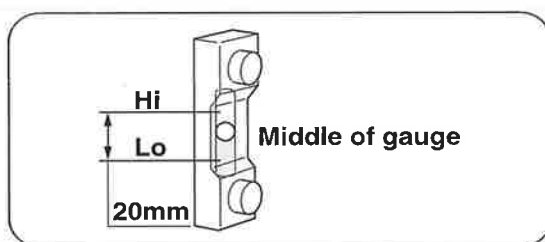
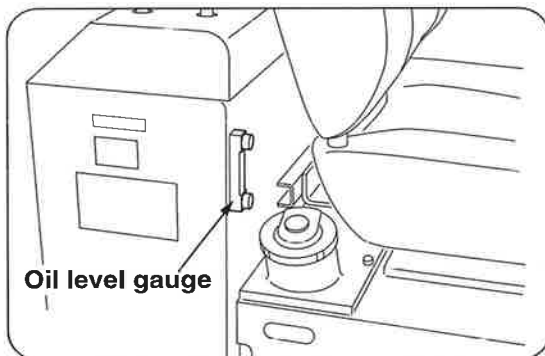

- Park the vehicle on a level ground and put the crane at the stored position to stop the engine.
- Since hydraulic oil temperature is too high and its volume is expanded immediately after the machine operation has been stopped, the oil level gauge will not indicate the correct oil quantity. Therefore, be sure to check the oil quantity when the oil temperature has returned to an ambient temperature of 20~40°C.
- Check the oil quantity at the oil level gauge located in front of oil tank.
- A proper oil level should be at the middle between “Hi” and “Lo” limits on the gauge.
- If hydraulic oil level is checked at the operating position of the crane, the oil may be over-supplied because hydraulic oil in each cylinder will not be returned to the oil tank. Therefore, be sure to check the oil level at the stored position.
- If oil level is found below the “LOWER” limit, remove the cover to the tank and remove the cap to fill it up with a specified oil.
- There is a risk that the hydraulic oil may be spurted out if the oil is supplied beyond the “Hi” level limit on the gauge.

MAINTENANCE AND INSPECTION OF CARRIER

◆7. Check for rubber crawler / Adjustment

⚠ WARNING

★Do not check rubber crawler tension with the crane body raised above the ground. It is very dangerous because an accidental fall of the crane may happen during inspection. Be sure to carry out tension check with the crane touched the ground.

Standard: 27~35mm
Adjust if less than 20mm

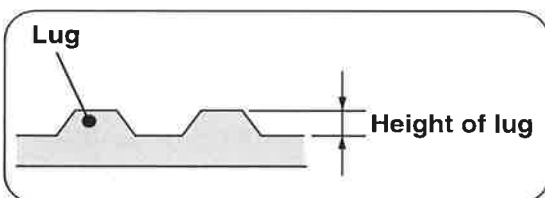
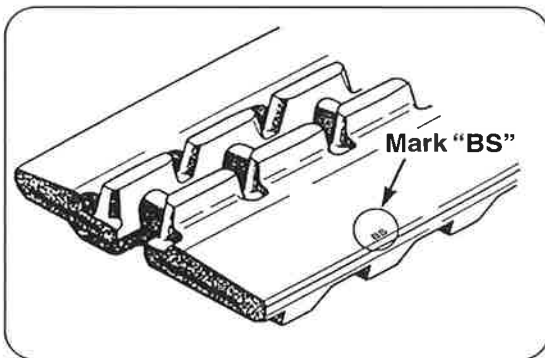
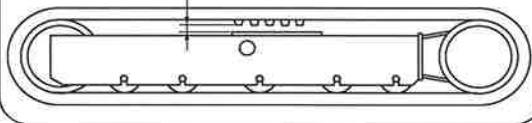

■ Inspection

Check the rubber crawler for wear and for tension as the wear varies according to operating and ground conditions.

- Check rubber crawler tension with the seam of rubber crawler positioned at the center between wheels at the other side of the ground.
- Putting the mark "BS" at the center between the wheels on ground side allows the seam to be positioned at the center of wheels on the other side. Wrong positioning shows larger slack of rubber crawler than the proper tension which results in re-adjustment.
- If the tension is too tight, it shortens service life of wheel sprocket.
- Replace the rubber crawler when the lug height becomes less than 3mm.

⚠ CAUTION

★Adjust the tension after 30 hours of operation if the new rubber crawler has been mounted.

MAINTENANCE AND INSPECTION OF CARRIER

■ Adjustment

! WARNING

★ **Pressurized grease is filled in the adjusting cylinder. Do not unfasten the plug by more than 1(one) turn because slackening of the plug too further or too quick allows the plug to pop out or the grease to spurt out which may invite an accident resulting in injury or death. Do not unfasten the grease nipple at this time.**

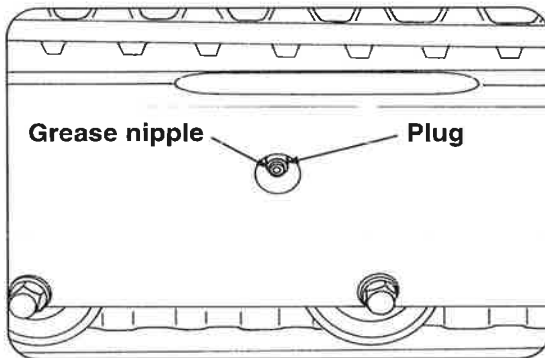

1 Inject the grease into the grease nipple from the lubrication hole on the truck frame and extend the grease cylinder.

2 Move the crawler back and forth to check the rubber crawler for proper tension.

3 Check the tension of rubber crawler again and adjust it if the proper tension has not been obtained.

4 If the tension is too loose even after the grease has been injected, it is necessary to replace the rubber crawler or the seal in the adjustment cylinder.

Ask UNIC or a UNIC authorized service shop for repair.

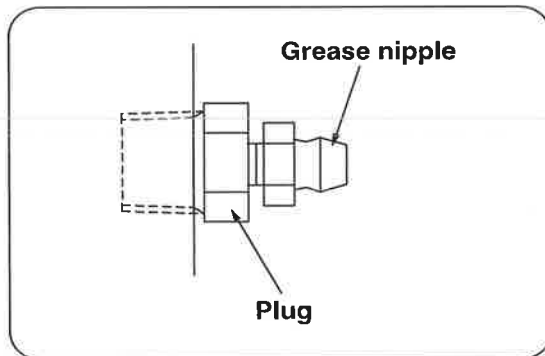

**MAINTENANCE AND INSPECTION OF CARRIER**
----- **CAUTION**

- ★ Do not crawl over lying rocks or stones with sharp edges.
- ★ Do not change direction where there is a difference in ground level.
- ★ Do not make a quick change of direction as it may cause the wheels to go off the rubber crawler.
- ★ Do not operate the crane on a ground being heated to the temperature of more than 60°C.
- ★ Do not stain the rubber crawler with oils such as fuel, hydraulic oil, grease, and the other oil.
- ★ Do not operate the crane at a place where salt content is abundant.
- ★ When storing the crane for long period of time, store it indoors where it will not be exposed to the ray of the sun or to the rain directly.

MAINTENANCE AND INSPECTION OF CARRIER

2 Inspection and Maintenance which is to be carried out every 250 hours or 3 months

- ◆ 1. Replacement of engine oil in the oil pan and engine oil filter element

! WARNING

- ★ Do not rush to replace engine oil as it is heated to a high temperature immediately after the engine has been stopped. Replace the engine oil after oil temperature has gone down.
- ★ Wipe up spilled engine oil thoroughly after replacement to avoid an accidental fire.

! CAUTION

- ★ Use of a oil filter which has been washed is strictly prohibited.

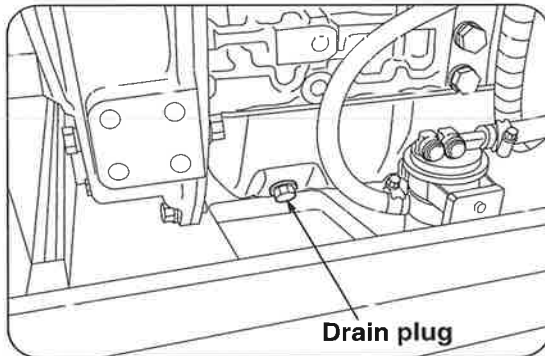

Drain plug is located on the left hand side of the oil pan.

- 1** Place a container under the drain plug and the oil filter to receive oil drained.
- 2** Remove the drain plug to discharge oil. Tighten the drain plug after oil has been drained.

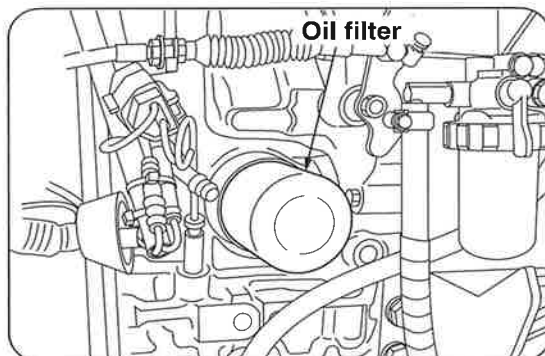

- 3** Rotate the oil filter counterclockwise to remove it. Use a filter wrench if it is too tight.

MAINTENANCE AND INSPECTION OF CARRIER

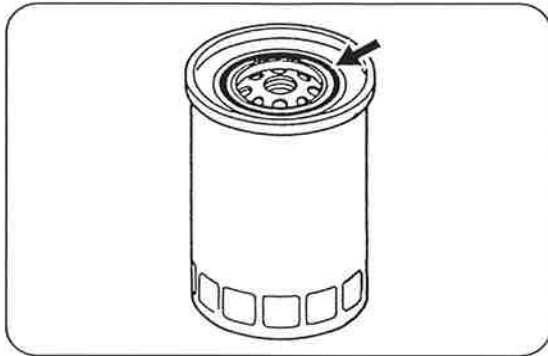

4 Apply oil sparingly to the packing of new oil filter.

5 Clean the filter bed to mount the new oil filter by rotating it clockwise.

Tighten it further by rotating approx. 2/3 turns from which the packing surface touches the seal surface on the filter bed.

Take care not to be over-tightened as it causes damage to the packing which in turn oil leakage results.

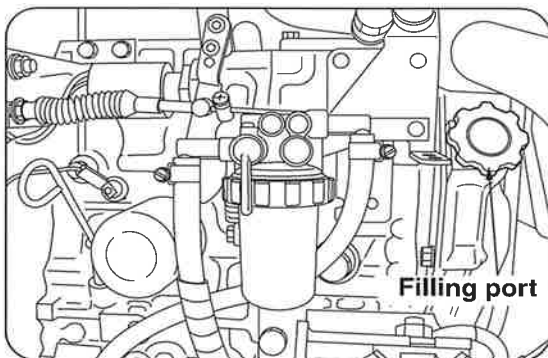

6 Pour the specified amount of oil which is fit to use in ambient temperature into the filling port.

Oil quantity to be replaced : 4.5 liters

7 Idle the engine to check for no oil leakage.

8 Stop the engine and wait for 5 ~ 10 minutes to check the engine oil level again.

Replace engine oil and oil filter element after 100 hours (1 month) of operation, then replace it every 250 hours (3 months) of operation thereafter.

MAINTENANCE AND INSPECTION OF CARRIER

**◆2. Check for air cleaner element /
Cleaning**

! WARNING

★Do not make a cleaning and a replacement of air cleaner while engine is running.

! CAUTION

★If the crane is operated in dusty environment, shorten accordingly the time when making inspection and cleaning.

Check and clean the air cleaner element when the crane has been operated for 250 hours (3 months) or when the lamp for warning clogging of air cleaner element lights.

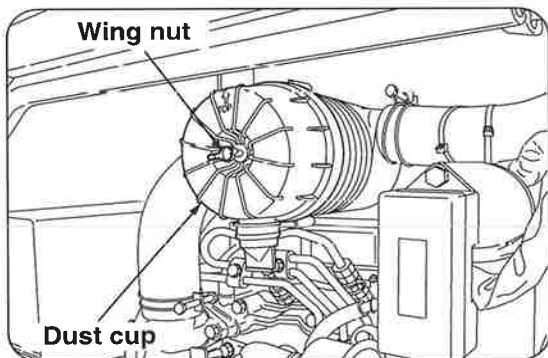

1 Unfasten the wing nut to remove the dust cup.

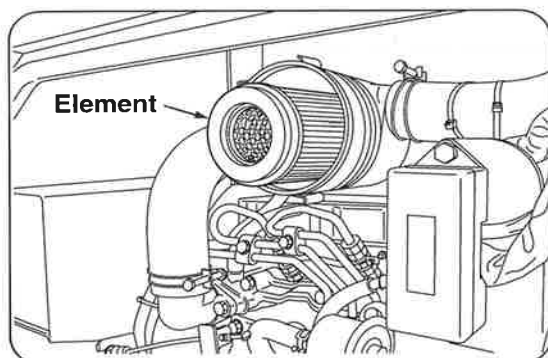

2 Take out the air cleaner element to check and clean the element.

MAINTENANCE AND INSPECTION OF CARRIER

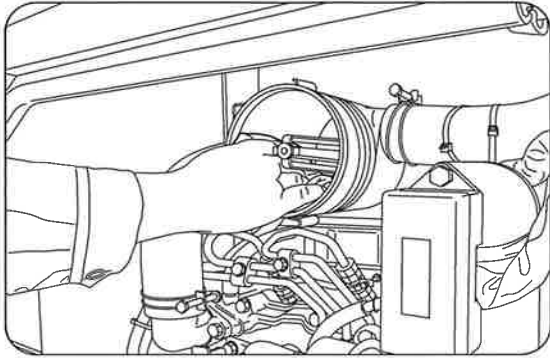

3 Wipe out inside of the body with a piece of clean cloth.

4 Attach a new or the cleaned element.

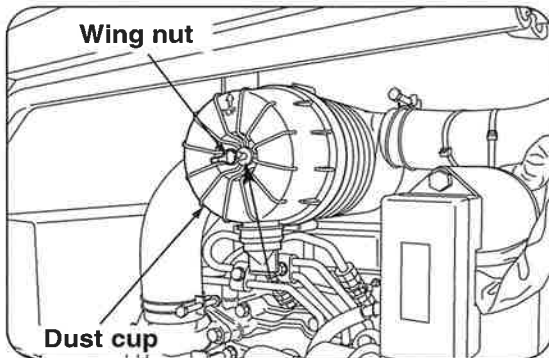

5 Fit the dust cup to secure it with the wing nut.

6 Check the air piping for tightness of piping such as in hose clamps.



MAINTENANCE AND INSPECTION OF CARRIER

 **CAUTION**

★If the monitor lamp lights soon after the cleaned air cleaner element has been fitted, replace it with new element.

★Repeated cleaning of the air filter element is up to 5 times. Do not try cleaning 6 times but replace it with new element.

MAINTENANCE AND INSPECTION OF CARRIER

◆3. Cleaning of element/Check

⚠ CAUTION



★Do not strike the air cleaner element or hit it against other object when cleaning the cleaner.

★Do not use a cleaner which has been damaged in the folds or gasket.

★Do not wash the element with water.

★Wear safety goggles when cleaning it by blowing a compressed air and set the air pressure to a level less than 0.2MPa (2kgf/cm²).

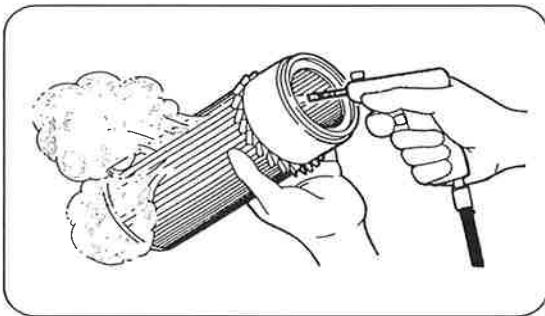

■Cleaning

Clean the element as follows:

●When it is soiled with dry dust:

Blow compressed air with a pressure of 0.2MPa (2kgf/cm²) to the inside of the element along the folds.



■Check

Check the element after cleaning.

Check visually the filter paper by lighting inside of the element.

Replace the element if any of damage, pin-hole, or particularly thin area in the filter paper has been found.

MAINTENANCE AND INSPECTION OF CARRIER

◆4. Cleaning of fuel filter element with water separator

! WARNING

★Do not rush to start cleaning of fuel filter as it is heated to a high temperature immediately after the engine has been stopped. Clean the filter after the oil has cooled down.

★Do not bring a fire source close to the working site.

★Wipe up spilled fuel thoroughly after cleaning as to avoid an accidental fire.

★Turn OFF the starter switch or disconnect the battery cable to the negative (-) pole before making a cleaning of the fuel filter with water separator.

★Wear safety goggles when cleaning it by blowing a compressed air and set the air pressure to a level less than 0.2MPa (2kgf/cm²).

★Do not wash the element with gasoline.

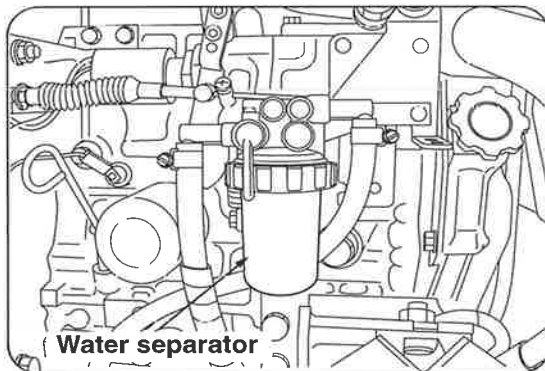

Fuel filter with water separator is to separate and remove deposited foreign object and moisture.

Clean it periodically as it is clogged with foreign particles over a long period of use.

MAINTENANCE AND INSPECTION OF CARRIER

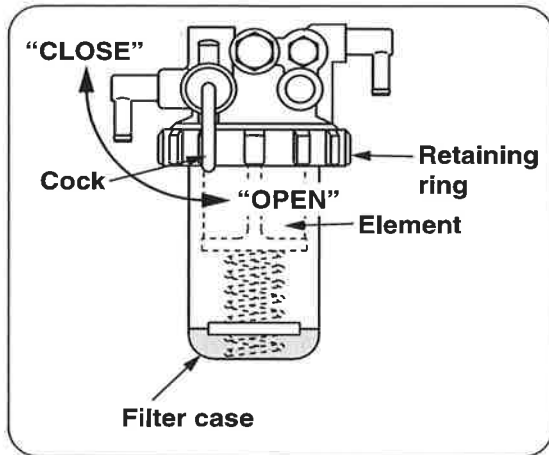

- 1** Throw the cock of fuel filter with water separator upward to "CLOSE" position. Turn the cock by more than 90°.
- 2** Unfasten the retaining ring to remove the filter case and the element.
- 3** Wash the element with a diesel oil and blow compressed air with a pressure of 0.2MPa (2kgf/cm²) to the inside of the element to remove dust.
- 4** Also remove foreign particles and moisture deposited on the bottom of filter case.
- 5** Check the O-ring, replace it with new O-ring if it is found damaged.
- 6** Fit the cleaned element in the filter case and tighten it into the filter bed with your hand.
In order to prevent it from being over-tightened, tighten the retaining ring by rotating approx. 2/3 turns from which the packing surface touches the seal surface on the filter bed.
- 7** Turn the cock on the fuel filter downward to "OPEN" position.
- 8** Bleed the air in the fuel system and check for fuel leakage.

MAINTENANCE AND INSPECTION OF CARRIER

◆5. Check oil quantity in the reduction gears of crawling motor/Filling up

! WARNING

★Do not rush to work as each section of crawling devices is heated to a high temperature immediately after the crane operation. Work after temperature of crawling devices have gone down.

★Pressure may be remained inside of the reduction gears of crawling motor. Unfasten the filling port plug by 2~3 turns slowly to release the internal pressure and then remove the plug. An abrupt removal of the plug may cause the plug to pop out or the oil to spurt out which is dangerous. Do not turn your body or face toward the plug.

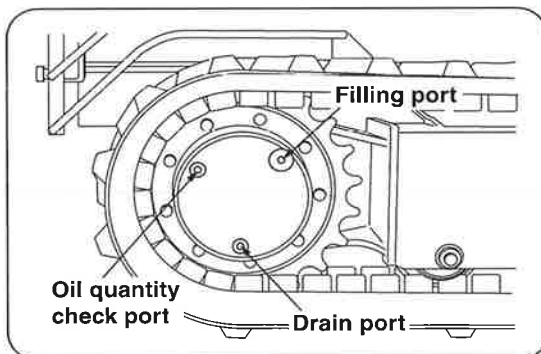

- 1** Park the crane on a flat ground.
- 2** Position 3 (three) plugs at the end of reduction gears of crawling motor as illustrated in the figure, "position for inspection", and stop the engine.
- 3** Unfasten the filling port plug slowly to bleed air.
- 4** Remove both plugs of filling port and oil quantity check port. A proper oil quantity is in the reduction gears if oil flows out of the oil quantity check port. If oil amount is insufficient, fill it with a specified oil.
- 5** Check the O-ring of each plug, replace it with new O-ring if it is found damaged.
- 6** Put the filling port plug and the oil quantity check port plug and tighten them.

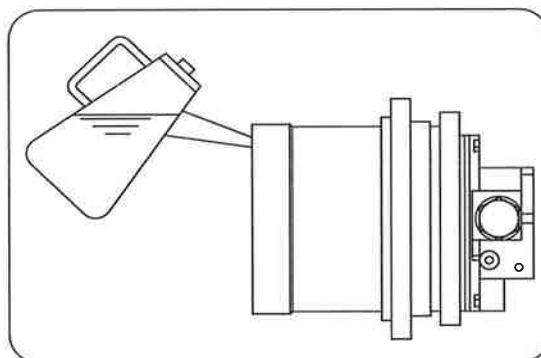

MAINTENANCE AND INSPECTION OF CARRIER

3 Inspection and Maintenance which is to be carried out every 500 hours or 6 months

Carry out "Inspection and Maintenance which is to be carried out every 250 hours or 3 months", illustrated in the previous section , together with this inspection and maintenance.

◆1. Replacement of fuel filter element with water separator

! WARNING

★Do not rush to start replacement of fuel filter as it is heated to a high temperature immediately after the engine has been stopped. Replace the filter after the oil has cooled down.

★Do not bring a fire source close to the working site.

★Wipe up spilled fuel thoroughly after replacement to avoid an accidental fire.

★Turn OFF the starter switch or disconnect the battery cable to the negative (-) pole before making a replacement of the fuel filter with water separator.

★Wear safety goggles when cleaning it by blowing a compressed air and set the air pressure to a level less than 0.2MPa (2kgf/cm²).

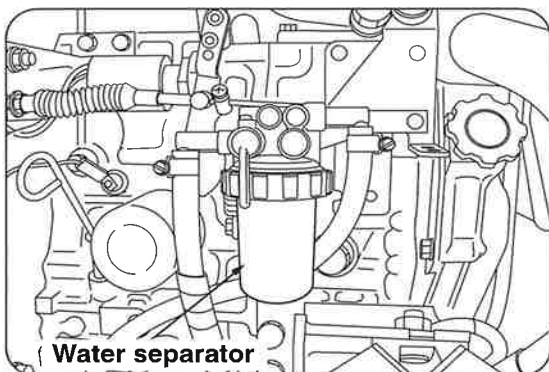

Fuel filter with water separator is to separate and remove deposited foreign object and moisture.

Replace it periodically as it is clogged with foreign particles over a long period of use.

MAINTENANCE AND INSPECTION OF CARRIER

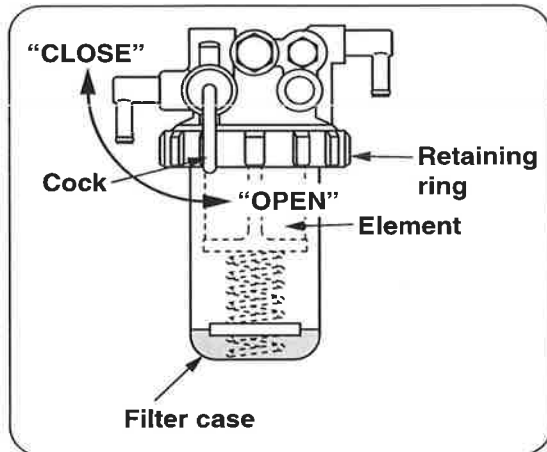

- 1** Throw the cock of fuel filter with water separator upward to "CLOSE" position. Turn the cock by more than 90°.
- 2** Unfasten the retaining ring to remove the filter case and the element.
- 3** Wash the filter case with diesel oil and fit the new element.
In addition, replace the old O-ring with the new one when replacing the filter element.
- 4** Clean the filter bed and mount the fuel filter in which the new element has been fitted.
Pay attention that the packing is not be damaged by twisting while it is fitting.
- 5** Turn the cock on the fuel filter downward to "OPEN" position.
- 6** Bleed the air in the fuel system and check for fuel leakage.

MAINTENANCE AND INSPECTION OF CARRIER

4 Inspection and Maintenance which is to be carried out every 1000 hours or 12 months

Carry out "Inspection and Maintenance" which is to be carried out every 250/500 hours or 3/6 months", illustrated in previous sections together with this inspection and maintenance.

- ◆ 1. Replacement of hydraulic oil in the oil tank and cleaning of suction strainer

! WARNING

★ Do not rush to start replacement of oil as it is heated to a high temperature immediately after the engine has been stopped.

Replace the oil after the oil has cooled down.

★ Remove the cap on the filling port after confirming that oil temperature has dropped.

★ Wipe up spilled oil thoroughly after replacement to avoid an accidental fire.

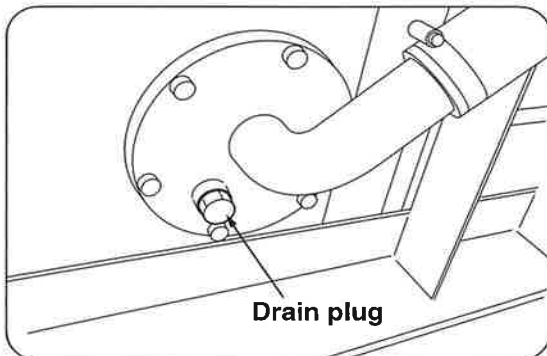
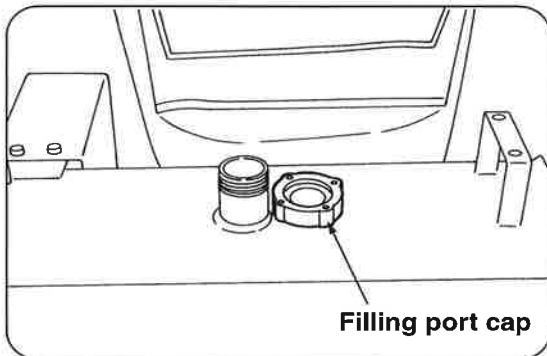

Replace hydraulic oil together with the line filter element at the same time.

- 1 Park the crawler on a flat ground to stop the engine.
- 2 Move each operation lever to release the internal pressure in the hydraulic system.
- 3 Remove the cap on the filling port slowly.
- 4 Place a container under the drain plug to receive oil being drained.
- 5 Remove the drain plug located on the bottom of hydraulic oil tank to drain oil. Capacity of hydraulic oil tank: 120 liters Prepare a container having enough capacity for holding as much as 120 liters.

MAINTENANCE AND INSPECTION OF CARRIER

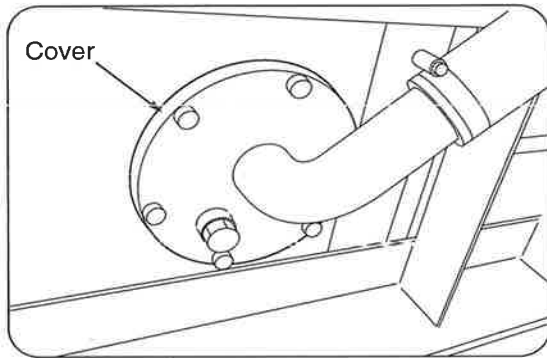

6 Remove the cover to take out the suction strainer after draining.

7 Remove dust stuck to the strainer and wash it with nonflammable wash oil. Replace the strainer if it is found damaged.

8 Check if there is foreign object deposited in the tank and wash inside of the tank with a wash oil.

9 Check the O-ring on the cover and replace it with new one if it is found damaged.

Check the O-ring of the drain plug to tighten it.

Replace the O-ring with a new one when it is damaged.

10 Fit the cleaned strainer to tighten the drain plug.

Then replace the line filter element.

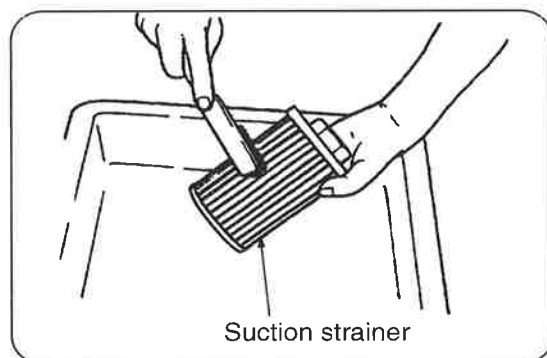
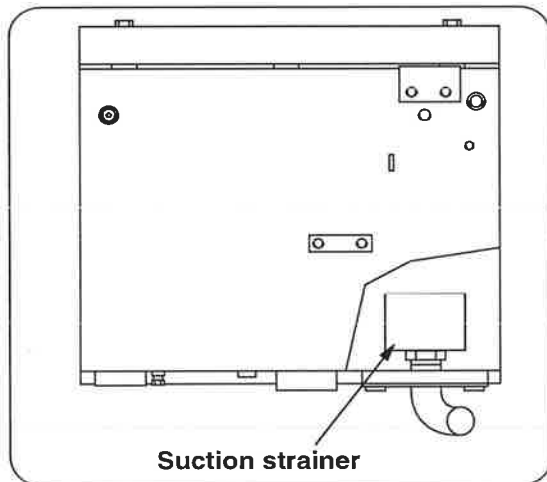

MAINTENANCE AND INSPECTION OF CARRIER

◆2. Replacement of line filter element

! WARNING

★Do not rush to start replacement of line filter element as it is heated to a high temperature immediately after the engine has been stopped. Replace the filter element after the oil has cooled down.

★Wipe up spilled fuel thoroughly after replacement to avoid an accidental fire.

The line filter is located inside the cover on the front of tank.

Replace hydraulic oil together with the line filter element at the same time.

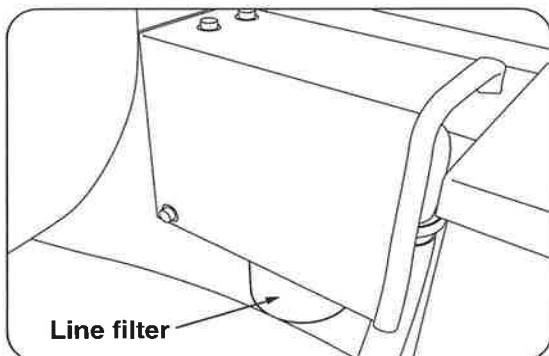

1 Place a container under the bottom of line filter to receive oil being drained.

2 Rotate the line filter counterclockwise to remove it.

Use a filter wrench if it is too tight.

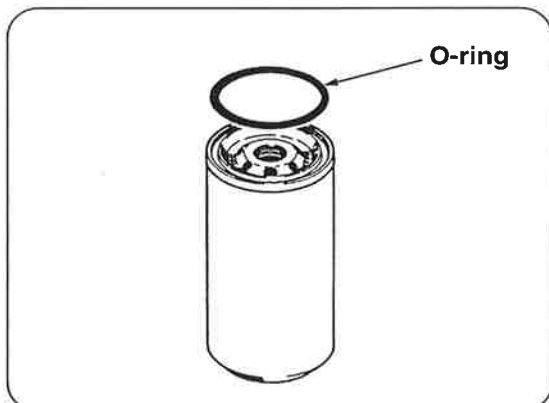

3 Apply oil sparingly on the packing of new oil filter.

4 Clean the filter bed to mount the new line filter by rotating it clockwise.

Tighten it further by rotating approx. 2/3 turns from which the packing surface touches the seal surface on the filter bed.

Take care not to be over-tightened as it causes damage to the packing which in turn oil leakage results.

MAINTENANCE AND INSPECTION OF CARRIER

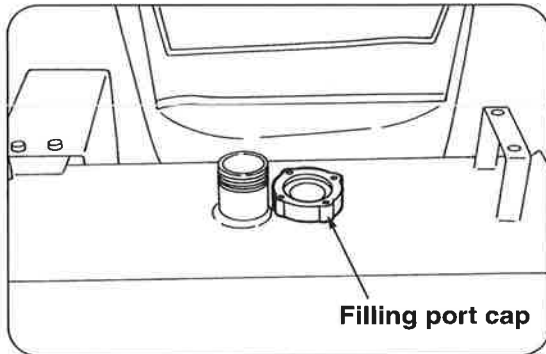

5 Pour the specified amount of specified oil into the filling port.

Capacity of hydraulic oil tank: 120 liters

6 Fit the filling port plug, then bleed the air in the hydraulic system.

7 Idle the engine at low speed and repeat extending and retracting each cylinder between positions where it will not come to the stroke end of either side (approx. 10cm before the stroke end).

CAUTION

★Extension or retraction of a cylinder to its stroke ends may cause the sealing to be damaged by the air entered into the cylinder.

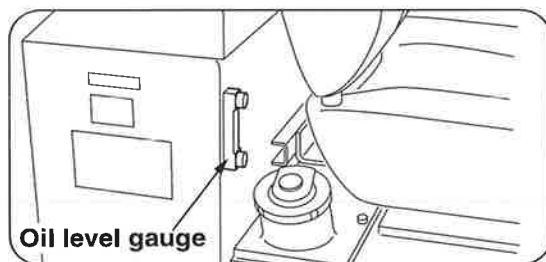

8 Then, allow each cylinder to repeat extending and retracting between both sides by 3 to 4 times.

9 Put the crane at the stored position and stop the engine.

Check the oil level gauge located in front of the oil tank, and supply the oil as necessary.

If hydraulic oil level is checked at the operating position of the crane, the oil may be over-supplied because hydraulic oil in each cylinder will not be returned to the oil tank.

Therefore, be sure to check the oil level at the stored position.

A proper oil level should be at the middle between “Hi” and “Lo” limits on the gauge.

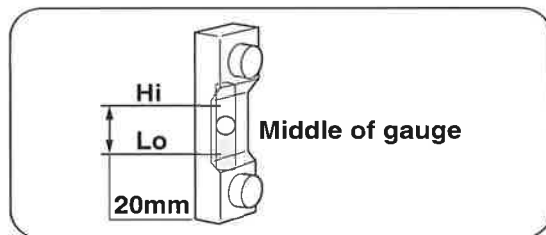

CAUTION

★Since hydraulic oil temperature is too high and its volume is expanded immediately after the machine operation has been stopped, the oil level gauge will not indicate the correct oil quantity. Therefore, be sure to check the oil quantity when the oil temperature has returned to an ambient temperature of 20~40°C.

★There is a risk that the hydraulic oil may be spurted out if the oil is supplied beyond the “Hi” level limit on the gauge.

MAINTENANCE AND INSPECTION OF CARRIER

◆3. Replacement of oil in the reduction gears of crawling motor

⚠ WARNING

★Do not rush to start replacement of oil as it is heated to a high temperature immediately after the engine has been stopped.
Replace oil after the oil has cooled down.

★Pressure may be remained inside of the reduction gears of crawling motor.
Unfasten the filling port plug by 2~3 turns slowly to release the internal pressure and then remove the plug.
An abrupt removal of the plug may cause the plug to pop out or the oil to spurt out which is dangerous.
Do not direct your body or face toward the plug.

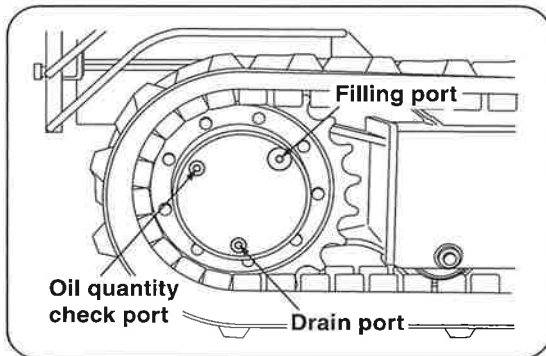

- 1** Park the crane on a flat ground.
- 2** Position 3 (three) plugs at the end of reduction gears of crawling motor as illustrated in the figure, "position for inspection", and stop the engine.
- 3** Unfasten the filling port plug slowly to bleed air.
- 4** Place a container under the bottom of the line filter to receive oil being drained.
- 5** Remove the drain plug first, then the filling port plug and the oil quantity check port plug to drain the oil thoroughly.
- 6** Check the O-ring of each plug, replace it with new O-ring if it is found damaged.

MAINTENANCE AND INSPECTION OF CARRIER

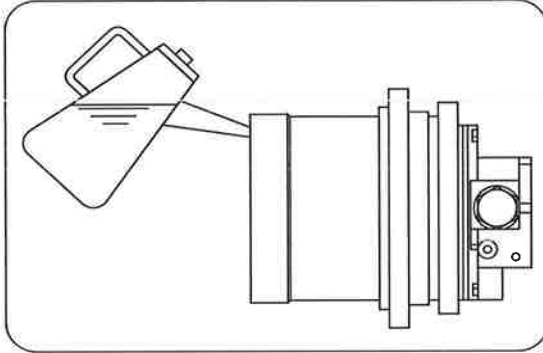

- 7** Tighten the drain plug and fill a specified oil in the filling port.
- 8** A proper oil quantity is to be confirmed when the oil is filled until it flows out of the oil quantity check port.
- 9** Put the filling port plug and the oil quantity check port plug and tighten them.

MAINTENANCE AND INSPECTION OF CARRIER

5 Non-regular maintenance

- ◆1. Check for cooling water quantity /Filling up

! WARNING



★Removal of the cap with the engine overheated allows steam and heated water inside to blow out which may cause a skin burn. In order to carry out the service for cooling system, stop the engine and wait until water temperature has gone down to a degree that the radiator cap can be opened with your hand.

★ When the radiator cap is removed, rotate it counterclockwise gradually to release the inside pressure.

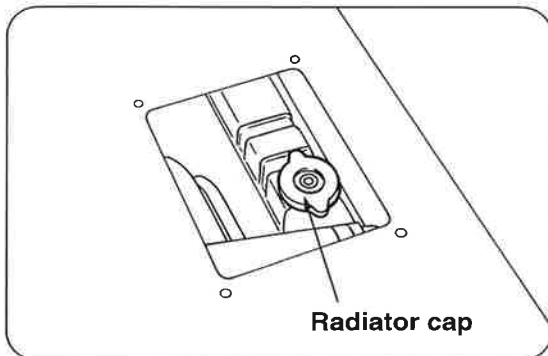
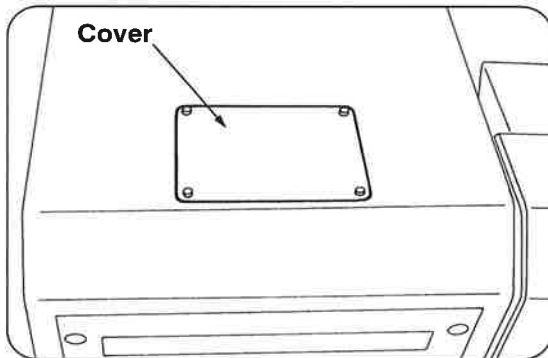

When replacing the cooling water, refer to the "list of recommended lubricant".

Be sure to wash inside of cooling system whenever the cooling water is replaced.

If the scale and the rust have been formed in the cooling system, a cooling efficiency decreases which may cause the engine to be overheated.

1 Park the crane on a flat ground and stop the engine for cooling down.

2 Remove the cover fitted on upper side of the engine hood and rotate the radiator cap gradually while releasing the inside pressure to remove the cap.

MAINTENANCE AND INSPECTION OF CARRIER

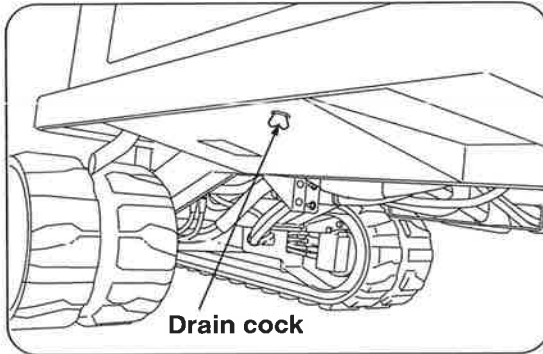

3 Unfasten the drain cock on the radiator to drain the cooling water.

4 Close the drain cock.

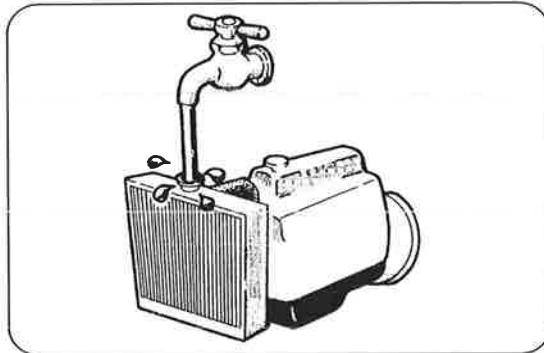

5 Wash it with a detergent available on the market.

Wash it by following the instructions attached to the detergent you bought.

(Run the engine at a speed slightly higher than the idling to raise the water temperature to a level of more than 80°C and keep it running for approx. 30 minutes. If the temperature is too low, overall washing will not be made because the thermostat is still closed.)

CAUTION

★Control the feeding water flow so that the water in the cooling system is always full during washing.

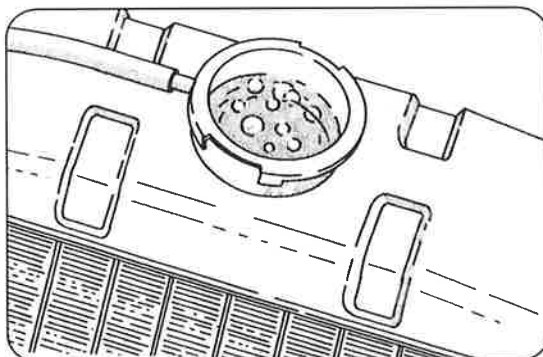

6 Discharge washing liquid thoroughly after washing and pour water in the cooling system from a water faucet.

Run the engine for about 10 minutes and drain the system.

Repeat the washing until clean water is discharged.

7 Pour water mixed with a rust-proof or anti-freeze solution unhurriedly and run the engine with the radiator cap removed to bleed the air thoroughly in the cooling system.

Quantity of cooling water: 6.0 liters

MAINTENANCE AND INSPECTION OF CARRIER

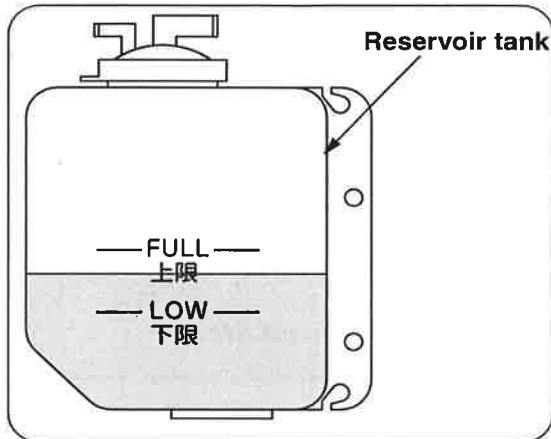

8 Stop the engine to adjust the cooling water quantity to a proper level. Fill the water until it comes to the neck of water supplying port and fill it to “FULL” mark on the reservoir tank.

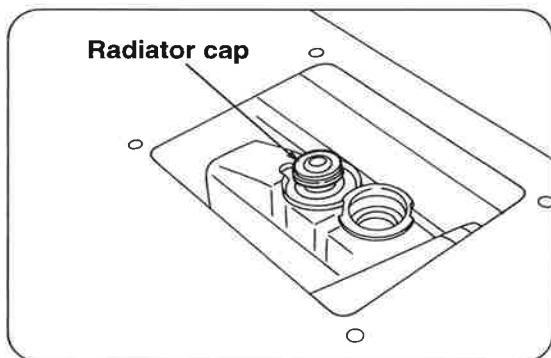

9 Check the radiator cap for damage in the packing and for fatigue in the spring which must be replaced with new one.

10 Fit the cap securely.

CAUTION

★ Check the rubber hoses for cracks and for setting due to fatigue which must be replaced. In addition, check the hose clamps for tightness.

★ Check the radiator fin that it has not been clogged with dust, insects, and other small particles.

Clean the fin by blowing water or compressed air if it is found clogged.



MAINTENANCE AND INSPECTION OF CARRIER

◆2. Inspection and Maintenance of the inside of fuel tank and fuel strainer

! WARNING

★Fuel is highly inflammable.
Turn the starter switch **OFF** and avoid any fire source while the fuel system is being maintained.

★Wipe up spilled fuel thoroughly to avoid an accidental fire.

Clean the inside of fuel tank if the engine is hard to be started and/or it gives insufficient driving power due to poor supply of fuel.

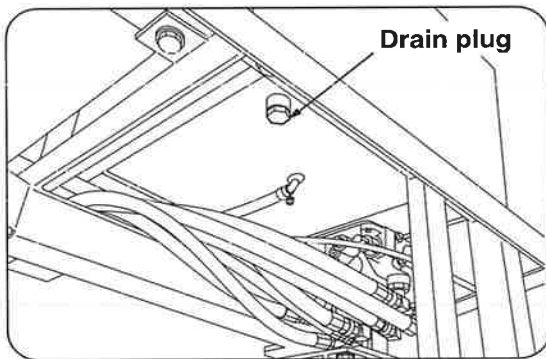

- 1** Place a container under the drain plug to catch the drain oil.
- 2** Remove the drain plug to drain the fuel.
- 3** Wash up inside of the tank with nonflammable wash oil.
- 4** Check the o-ring of the drain plug to tighten it.
Replace the o-ring with a new one when it is damaged.
- 5** Bleed air out of the fuel system and check for fuel leakage.



MAINTENANCE AND INSPECTION OF CARRIER

◆3. Air bleeding out of fuel system

⚠ CAUTION

★Continuous running of starter motor allows the battery to be discharged and the starter motor itself to be damaged.

Do not energize the motor for more than 20 seconds without a break.

★If it failed to start the engine, take a rest for 1 or 2 minutes to try it again.

In order to bleed the air out of the fuel system, turn the starter switch to “START” position for a few seconds then the engine starts.



MAINTENANCE AND INSPECTION OF CARRIER

◆4. Cleaning and Inspection of radiator fin

⚠ WARNING

★Wear safety goggles when cleaning it by blowing a compressed air and set the air pressure to a level less than 0.2MPa (2kgf/cm²).

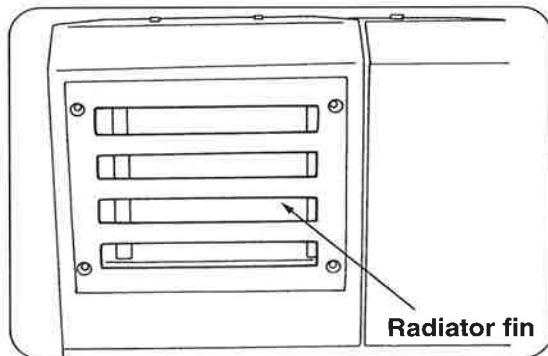

If the fin is clogged with something such as dust and leaves, it prevent the air from flowing through to decrease cooling efficiency remarkably which in turn causes the engine to be overheated.

Blow water or compressed air against the fin for cleaning if it is found to be clogged.

When washing it with water, take care not to wet the alternator with water.



MAINTENANCE AND INSPECTION OF CARRIER

6 Storage

! WARNING

★ Stop the engine and thoroughly remove dirt and dust stuck on the carrier body.

In particular, be sure to remove the dust stuck to the battery, electric wiring, and the members directly affected by engine heat such as muffler as it may cause a fire.

★ In order to prevent those who are not in charge such as children from access to the crane, cover the crane or store it in a storage house. Cover the crane after all the heated parts in the crane body have been cooled down, otherwise it may cause a fire.

★ Shift each crawling lever at its neutral position to lock it.

★ If ambient temperature is expected to go below the freezing point, drain the water in radiator or add an antifreezing fluid to the water to prevent it from freezing.

★ Avoid storing the crane where it is to be exposed to the direct rays of sun as the crawler made of rubber.

★ Disconnect a negative (-) side of battery cable if the crane is to be stored for a long period of time. Failure to do this may cause a fire due to short-circuited such as by biting of a rat.

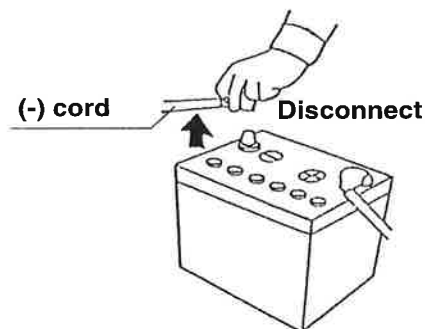



MAINTENANCE AND INSPECTION OF CARRIER

7 Fitting safety covers

⚠ WARNING

★ Be sure to fit the safety covers removed during inspection and maintenance where they were fitted originally. It is very dangerous because uncovered rotating members and heated parts may cause injury.

8 Maintenance and inspection of engine

Carry out the maintenance and inspection of engine according to “Instruction manual for engine”.



14. MAINTENANCE AND INSPECTION OF CRANE

⚠ WARNING

★ **Caution signboard**

Be sure to hang a “caution signboard” such as on control levers while either maintenance or inspection is being carried out, and do not try operating the crane.

★ **Be sure to replace consumable items according to the replacement criteria.**

Failure to observe the replacement as specified may cause a breakdown and warranty will not be given even if it is within the period to be applied.

★ **When a part needs to be replaced or anything abnormal is found, contact a UNIC service shop for consultation or for ask inspection or repair as soon as possible.**



MAINTENANCE AND INSPECTION OF CRANE

1 Inspection before operation

In order to secure safe operation and improve working efficiency, be sure to inspect each part of the crane according to the table as follows:

| Device | Servicing item | Device | Servicing item | Device | Servicing item |
|--------------------|---|-------------------------------------|--|--|--|
| Pump | Tightness of each mounting Oil leakage Unusual noise | Hook | Rotation of hook Function of hook retaining mechanism | Searcher hook | Function Deformation Cracks Mounting of fixing pin |
| Hydraulic oil tank | Oil level Oil leakage | Wire rope | Damage Condition of rope-end fixing | Slinging implements | Items necessary for crane operation are provided |
| Outriggers | Natural descent Function Control lever return Deformation Damage Oil leakage Cracks | Overwinding alarm | Function Proper buzzer sound | Automatic storing device for hook | Function of automatic stop and storing operation |
| Hoisting winch | Function Control lever return Braking function Irregular winding | Interlock for crane-crawl operation | Check that crane will not actuate on crawling, and crawler will not travel on crawl lever return and on crane operation. | Automatic stop for leaving minimum wire rope | Further unwinding stops automatically when remaining wire rope on the drum comes to 3 turns. |
| Slewing device | Function Control lever return Oil leakage | Warning horn | Function | | |
| Derricking boom | Function Control lever return Oil leakage Mounting of foot-pin | Piping, Hydraulic hose | Oil leakage Damage | | |
| Telescoping boom | Function Control lever return Oil leakage Deformation Cracks Mounting of fixing pin | Frame | Mounting of crane body Cracks Tightness of bolts Missing bolt | | |
| | | EXT. JIB | Function Deformation Cracks Mounting of fixing pin | | |

⚠ CAUTION

★ Perform monthly and annual inspection according to the separate service report.

★ Keep the crawler crane in good condition so that it will be always ready for normal operation.

MAINTENANCE AND INSPECTION OF CRANE

2 Cleaning

Keep the crane clean at any time.

Sands and fine dusts may cause an abnormal wear .

Do not wash the crane by splashing highly pressurized water to prevent it from entering into the electric system which may cause malfunction of the crane.

3 Inspection of bolts mounting slewing bearings

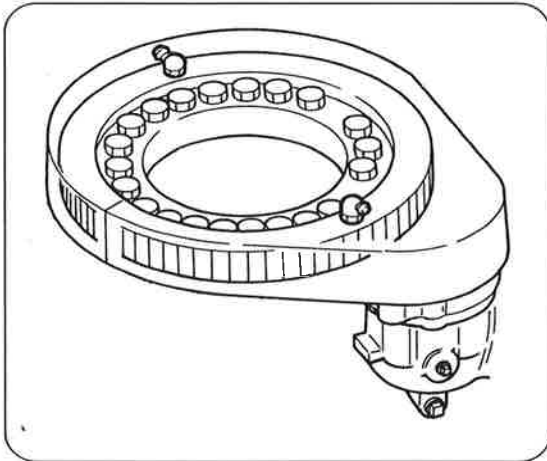

When the slewing device makes an unusual noise while operating or crawling the crane, or when a gap is created on the mounting surface, contact a UNIC authorized service shop for inspection and/ for repair.

⚠ CAUTION

★**Break of the bolts mounting slewing bearings invite an accident such as overturn and destruction of the crane. Check the mounting bolts (outer ring side) for tightness once every 6 months.**

MAINTENANCE AND INSPECTION OF CRANE



4 Replacement of wire rope (for winding-up)

Wire rope is an expendable article and it will be damaged and its strand wires are broken to allow it to be thinner through a long period of operation.

Replace the rope according to following criteria.

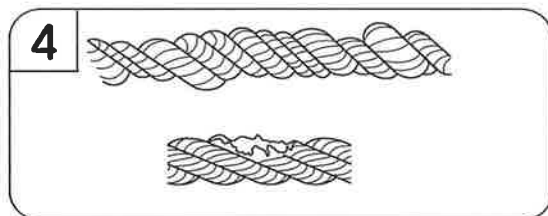
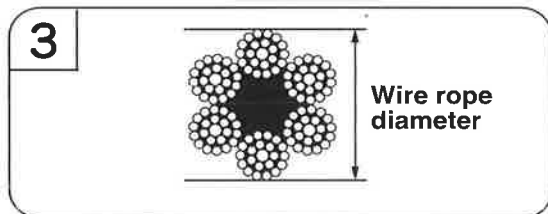
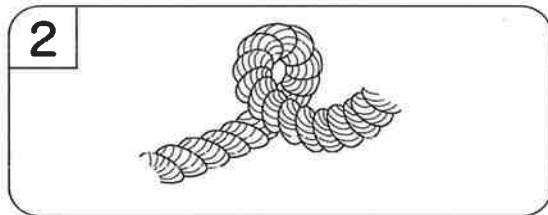
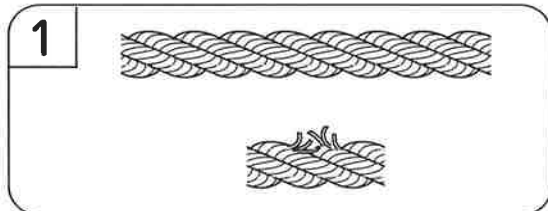

◆ **1. Replacement criteria**

1. A rope in which amount of broken strand wires (except filler wires) comes to more than 10% within a pitch of twist.

Replace the wire ropes intended for use with this crane if 13 pieces of strand wire have been broken within a pitch of twist.

2. A rope being kinked.

3. A rope from which its diameter has decreased by more than 7% of the nominal diameter.

For example, if wire rope with a nominal diameter of 10mm is used, replace it when the diameter becomes 9.3mm.

Refer to the section 17. MAJOR SPECIFICATIONS, for length and construction of the wire rope for winding-up.

4. A rope which has been deformed and/or corroded excessively.

★ **Be sure to replace a wire rope when it comes under the criteria, item 1 through 4, illustrated above.**

CAUTION

★ **Wear leather gloves when replacing wire ropes.**

MAINTENANCE AND INSPECTION OF CRANE

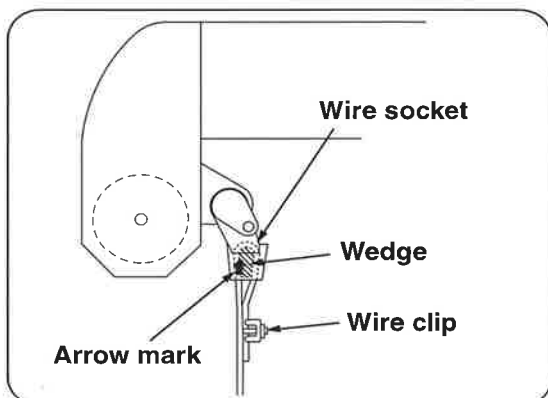
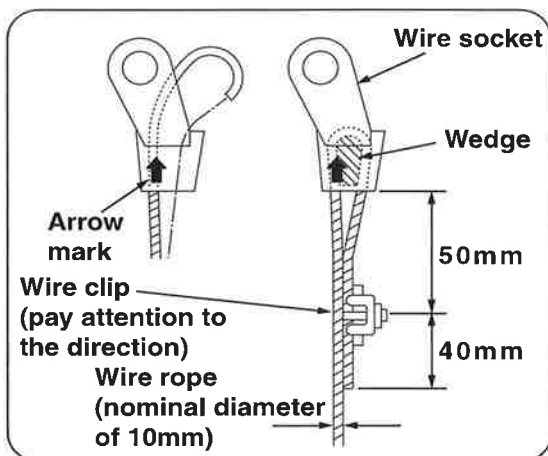
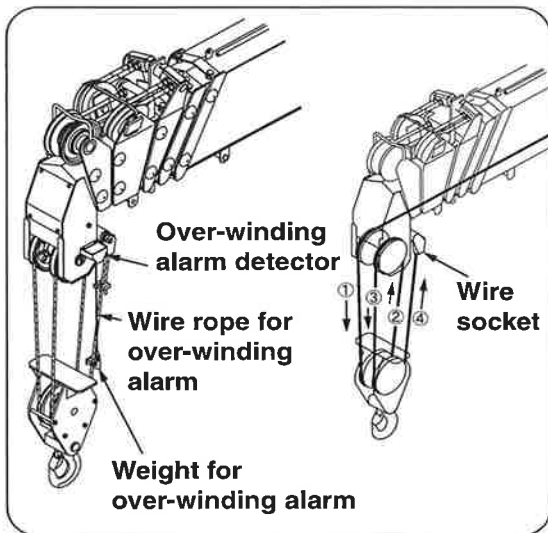

◆2. How to replace wire ropes

1. Follow the figure on the left for how to sling the wire rope for winding-up and determine mounting position of the weight for over-winding alarm.

2. How to fasten the end of wire rope

① When passing the wire rope, pass it along the arrow mark indicated on the wire socket. If it has been passed in the opposite direction, service life of the wire rope is shortened as it is kept bent all the time.

② Be sure to attach both the wedge and the wire clip as indicated in the figure on the left.

③ When mounting the wire socket to the boom, the arrow mark indicated on the wire socket comes outside as in the figure on the left.

MAINTENANCE AND INSPECTION OF CRANE

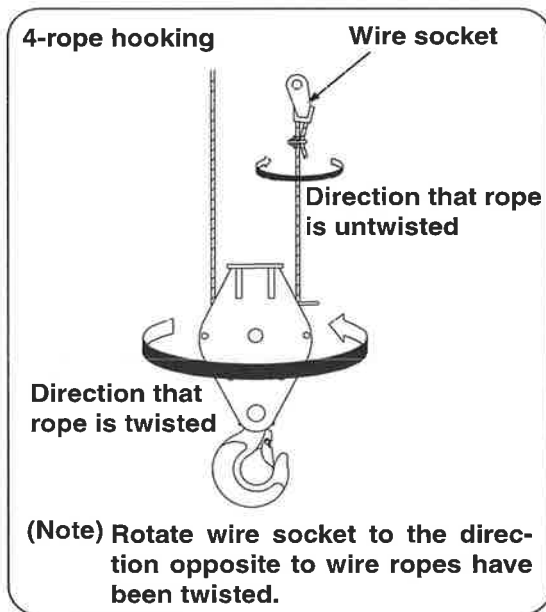
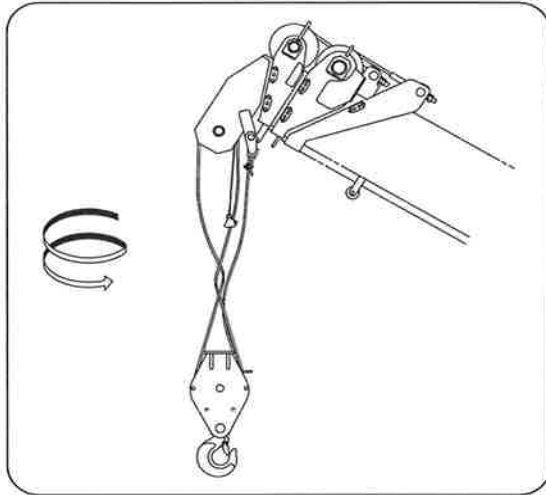

◆3. How to correct twisted wire ropes

Wire ropes tend to turn in untwisting direction when they are under tension.

If two or more wire ropes are hooked together, they tend to be twisted particularly while they are new.

The twist will decrease as the ropes are getting fit to the crane.

If wire ropes are twisted, correct them as follows:

1. Unload the hook.
2. Extend the boom fully.
3. Raise the boom to an angle of approximately 65°.
4. Unwind the hook until it comes close to the ground.
5. Check how many turns the wire rope has been twisted.
6. Wind up the hook and retract the boom to be on a stored condition.
7. Remove the wire socket and turn the socket in the untwisting direction by as many turns as the wire ropes have been twisted multiplied by the number of wire ropes being hooked. However, remember that the wire socket may be turned up to 4 turns at a time.
8. Attach the wire socket and repeat winding up and down the rope 2 or 3 times between both extremes. Then, check if twist of the wire ropes is corrected. If they remain twisted, repeat the procedures shown above.

MAINTENANCE AND INSPECTION OF CRANE

5 Replacement of expendable parts

◆1. Replacement of gaskets and seals for each cylinder

Although timing of replacement of a part varies according to how frequently the crane has been operated, replace gaskets and seals used in each cylinder after every 3 years of operation (period during which crane has not been operated is included) in order to operate the crane safely.

Ask a local UNIC authorized service shop for replacement of gaskets and/or seals.

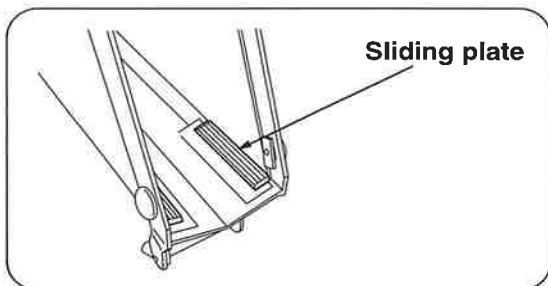

◆2. Replacement of sliding plate of boom

Replace it every 3 years.

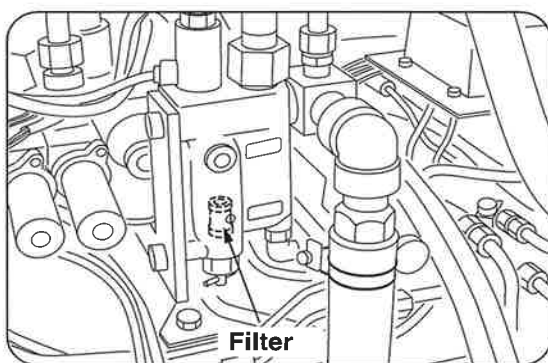

◆3. Cleaning and replacement of filter in the control valve

If the filter built in the control valve is clogged up, radio remote control operation and acceleration interlocking operation cannot be carried out.

Clean it by blowing air once after one year of use and replace it if it has been clogged up remarkably or it has been damaged.



15. WATER SUPPLY AND LUBRICATION TO CARRIER

WARNING

★Be sure to stop the engine, and store the boom and the outriggers before carrying out filling/replacing lubricant and/or fuel.

★A fire source such as smoking cigarette in mouth is strictly prohibited.

★Do not rush to start supply of water, filling fuel, and lubrication as the engine and the parts close to the engine is heated to a high temperature immediately after the engine has been stopped.

1 *Precaution when carrying out filling water and lubrication*

Lubricate according to “Lubrication chart” and keep the following instructions in mind when carrying out filling water and lubrication.

1. Clean filling ports and grease nipples thoroughly before carrying out lubrication.
2. Always supply new lubricant and prevent dusts from entering inside.
3. When supplying grease into each grease nipple, be sure to inject it until old grease is forced out of it.

CAUTION

★In order to ensure smooth operation of each part of the crane, minimum wear, and longer service life, be sure to supply lubricant as well as hydraulic oil which is indispensable to drive hydraulic equipment.

★Warranty will not be given, even if it is within the period to be applied, for failure to observe the replacement of lubricant as specified.



WATER SUPPLY AND LUBRICATION TO CARRIER

2 List of recommended lubricant

◆1. Use the engine oils as below:

| Classification | Depending on atmospheric temperature | | | | | | |
|--|--------------------------------------|--------|-------|---|-----------|----|----|
| | -30 | -20 | -10 | 0 | 10 | 20 | 30 |
| Rating to be applied | | | | | | | |
| Engine oil Diesel engine oil of CD class | SAE5W | | SAE30 | | | | |
| | | SAE10W | | | SAE10W-30 | | |

The selection of engine oil is very important to a diesel engine. If an unsuitable oil is used, or oil change is neglected, it may result in damage, and a shorter engine life. Use oils that meet API Engine Service Classification CD.

◆2. Use the recommended grease for lubrication as below.

Chassis grease
Use NLGI No. 2 grade for most temperatures.
Use NLGI No. 1 grade for extremely low temperatures.

◆3. Use the fuel as specified below. (Diesel fuel oil)

Use ONLY clean, high-quality fuel.
Use Grade No. 2-D fuel above 4°C.
Use Grade No. 1-D fuel below 4°C.

◆4. Use an antifreezing solution for coolant

- Antifreezing solution functions to prevent the water from freezing and the cooling system from rusting.
- Use an antifreezing solution if atmospheric temperature goes below the freezing point.
- Use “Long Life Coolant (LLC)” as the antifreezing solution.
The “Long Life Coolant” can be used throughout the year.
Replace the “Long Life Coolant” once every other year (in the season of autumn or fall).
(Follow the instruction of the manufacturer on how much the antifreezing solution should be mixed with water.)

⚠ CAUTION

★Use the softened water with less impurity such as tap water for cooling water.

Do not use well water and river water as cooling water.

★Use of coolant which too much of antifreezing solution mixed with water allows the engine to be overheated earlier.

16. LUBRICATION TO CRANE

WARNING

★Do not carry out maintenance and inspection while temperature of hydraulic oil is still high.

★Be sure to stop the engine to carry out lubrication.

★Temperature of both hydraulic and gear oils is high immediately after crane operation so that accumulated high pressure still remains inside. Uncapping the filling port, draining oil, and replacing filter while oil temperature is high allow the hydraulic and/or gear oils to spout out and a scald may result.

1 *Precaution when carrying out lubrication*

Lubricate according to “Lubrication chart” and keep the following instructions in mind when carrying out lubrication

1. Clean filling ports and grease nipples thoroughly before carrying out lubrication.
2. Always supply new lubricant and prevent dusts from entering inside.
3. When supplying grease into each grease nipple, be sure to inject it until old grease is forced out of it.

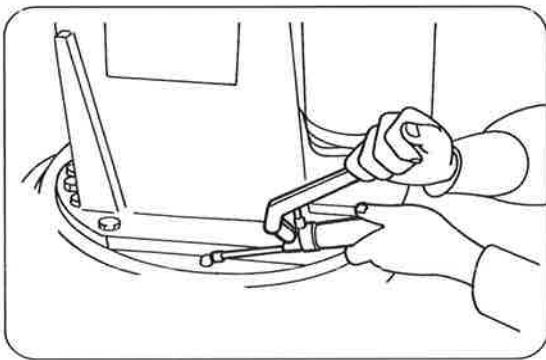

CAUTION

★In order to ensure smooth operation of each part of the crane, minimum wear, and longer service life, be sure to supply lubricant as well as hydraulic oil which is indispensable to drive hydraulic equipment.

★Warranty will not be given, even if it is within the period to be applied, for failure to observe the replacement of lubricant as specified.



LUBRICATION TO CRANE

2 List of recommended lubricant

◆1. List of recommended lubricants

★ Use the UNIC genuine hydraulic oils listed below as hydraulic oil for the crane.

Use industrial-type hydraulic oil

ISO VG 46 for temperatures above 32F.

ISO VG 22 for temperatures below 32F.

| Petroleum Maker | Brand | |
|-----------------|---------------------|----------------------|
| | ISO VG 22 | ISO VG 46 |
| MOBIL | Mobil DTE 22 | Mobil DTE Oil Medium |
| CALTEX | Spindura oil 22 | Rando Oil 46 |
| SHELL | Shell Tellus Oil 22 | Shell Tellus Oil 46 |

★ Use the recommended lubricants listed below as gear oil for lubrication.

| Aplication | Petroleum Maker | Brand |
|--------------------------|---|---|
| Reducer for winch | Shell | Shell Spirax EP 90 |
| Reducer for slewing gear | Use API service GL-4 SAE 90 gear oils. (Refer to the followings) | |
| | MOBIL CALTEX SHELL | Mobilube GX 90 Universal Thuban SAE 90 Shell Spirax EP 90 |

★ Use the recommended greases listed below as grease for lubrication.

(a) Chassis grease

Use NLGI No. 2 grade for most temperatures.

Use NLGI No. 1 grade for extremely low temperatures.

(b) Molybdenum grease

Use NLGI No. 2 grade.

| Petroleum Maker | Brand |
|-----------------|--------------------|
| MOBIL | Mobilplex Special |
| CALTEX | Molytex Grease EP2 |
| SHELL | Retinax AM |



LUBRICATION TO CRANE

3 Lubrication chart

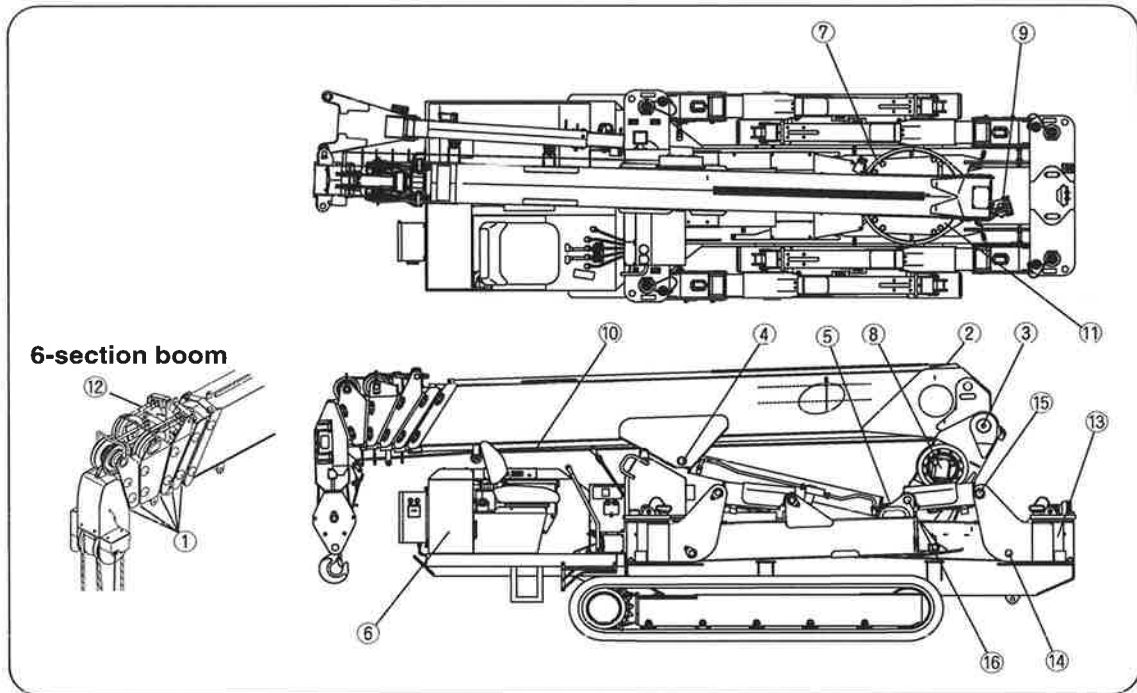

| Service interval | Where to lubricate | No. of part | Lubricant | Tool |
|--|---|----------------|---|--------------------|
| Daily | ① Boom slide plate (Underside & side face of boom sections ②, ③, ④, ⑤ and ⑥) For 6-section boom | 5 | Molybdenum grease | Manual application |
| | ② Boom slide plate (Upper side of boom section ①) | 2 | Molybdenum grease | Grease pump |
| | ③ Boom foot pin | 1 | Chassis grease | Grease pump |
| | ④ Upper support pin of derrick cylinder | 1 | Chassis grease | Grease pump |
| | ⑤ Lower support pin of derrick cylinder | 1 | Chassis grease | Grease pump |
| | ⑥ Oil tank (120 liters) | 1 | Hydraulic oil (up to middle of level gauge) | |
| Weekly | ⑦ Slewing gears | 1 | Chassis grease | Manual application |
| Monthly | ⑧ Winch reduction gears (Approx. 1.4liter) | 1 | Gear oil | |
| | ⑨ Slewing reduction gears (Approx. 1.4 liters) | 1 | Gear oil | |
| | ⑩ Wire rope | 1 | Rope grease | Spray gun |
| | ⑪ Slewing bearings | 2 | Chassis grease | Grease pump |
| | ⑫ Wire rope for boom extension | 1 | Rope grease | Spray gun |
| | ⑬ Outrigger fulcrum pin | 4 | Chassis grease | Grease pump |
| | ⑭ Outer box support | 4 | Chassis grease | Grease pump |
| | ⑮ Outrigger vertical cylinder (Bracket side) | 4 | Chassis grease | Grease pump |
| ⑯ Outrigger vertical cylinder (Outer box side) | 4 | Chassis grease | Grease pump | |

LUBRICATION TO CRANE

4 Lubrication

◆1. Replacement of gear oil (Winch reduction gears)

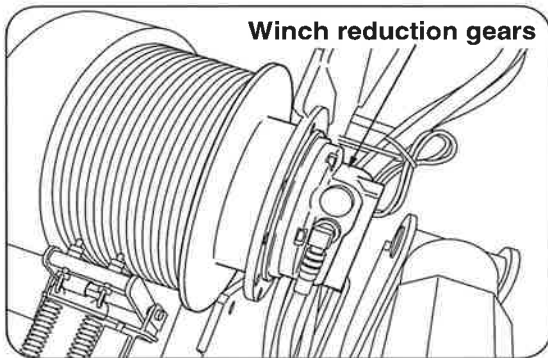

1. Remove the cover of the hoist winch.
Pay attention to the collar when removing the cover.
2. Bring both the filling port and the drain port to be vertical against the horizontal plane.
3. Drain gear oil out of the drain port.
4. Pour specified quantity of gear oil (1.4 liters) into the filling port.
5. Plug each port.

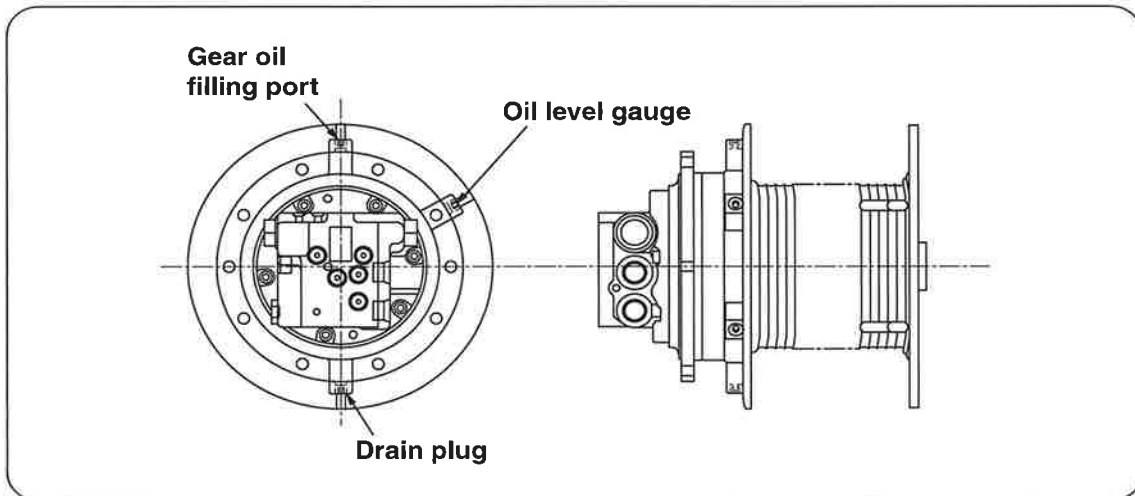

LUBRICATION TO CRANE

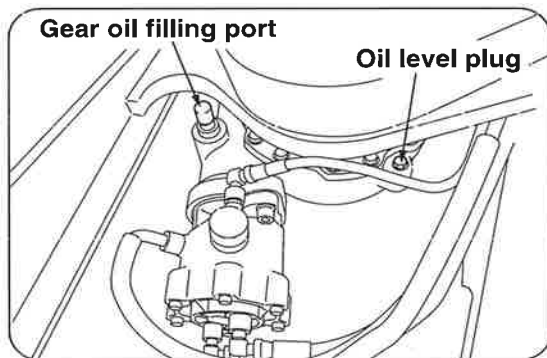
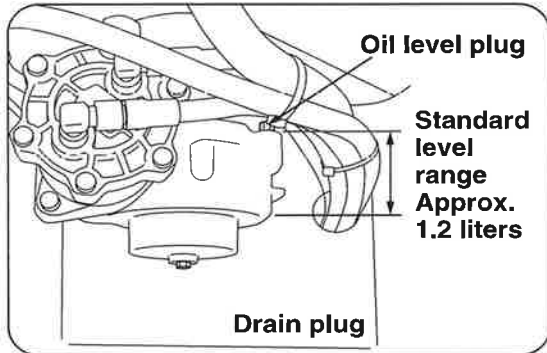

**◆2. Replacement of gear oil
(Slewing reduction gears)**

★Air enters in and out of the gear case so that dirt and moisture are brought in the gear case.

In addition, since hydraulic equipment gradually wears to produce worn particles, replace gear oil 6 months after the start of operation.

★After that, replace gear oil:

- Once a year for winch reduction gears, and
- Once every 2 years for slewing reduction gears.

⚠ CAUTION

★Replace gear oil after oil temperature has dropped.

★Fill the gear oil for winch reduction gear to a middle of oil level gauge (approx. 1.0 liter).

LUBRICATION TO CRANE

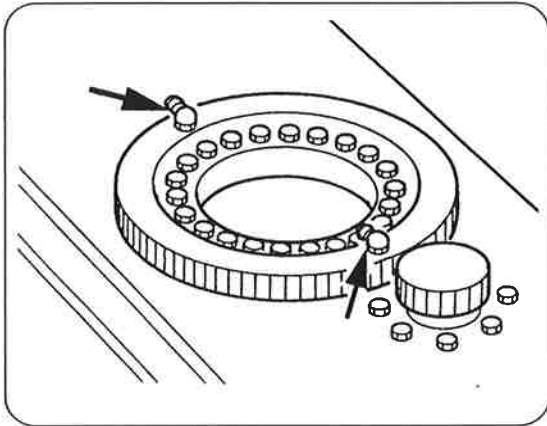

◆3. Lubrication to slewing bearings

The crane employs ball bearings as the slewing bearing.

Be sure to lubricate the bearings as insufficient lubrication may cause it to make unusual noise.

Grease in the nipples while slewing the boom once a month for moderate operation, and once a week for heavy-duty operation.

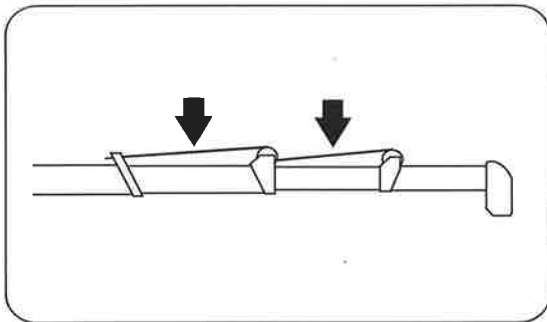

◆4. Lubrication to wire ropes for boom extension

Spray the rope grease sufficiently once a month to the wire ropes for boom extension with the boom fully extended.



MAJOR SPECIFICATIONS

1 URW706C2E (6-section boom)

(Speed indicated in the table below is at oil temperature range of 45~55°C, operating with no-load, and at rated pump discharge.)

Major specifications

| | | |
|------------------------------------|-------------------|---|
| Crane capacity (Net rated load) | | 6.0t × 3.0m (With outriggers, extended fully) |
| Maximum lift above ground (Hook) | | 19.5m |
| Boom to be extended to: | | 4.8m~7.7m~10.6~13.5m~16.3m~19.2m |
| Maximum working radius | | 18.6m |
| Speed of winding-up (Rope speed) | | 44m/min (At 4th layer on the drum) |
| Hoisting speed of hook | | 11m/min (At 4th layer on the drum, with 4-part line hooking) |
| Extending speed of boom | | 14.4m/52sec |
| Raising speed of boom | | 0°~80°/16sec |
| Slewing speed | | 2.5r.p.m. |
| Slewing range | | 360° (Continuous) |
| Hoisting rope | Construction | IWRC6 × P Fi (29) [Breaking load: 92.2kN (9400 kgf)] |
| | Diameter × length | 10mm × 111m |
| Outrigger | Horizontal | Direct pushing by double acting hydraulic cylinder (directly connected to hydraulic automatic locking device) |
| | Vertical | Direct pushing by double acting hydraulic cylinder (directly connected to hydraulic automatic locking device) |
| | Rated pressure | Crane: 20.6MPa(210kgf/cm ²) Crawl: 24.5MPa(250kgf/cm ²) |
| | Rated discharge | Approx. 81 ℓ /min |
| | Rated rotation | Approx. 2500rpm |
| Hydraulic oil tank capacity | | 120 liters |



MAJOR SPECIFICATIONS

Equipment and construction

| | |
|------------------|--|
| Boom telescoping | Boom: 6-section, Hexagonal box beam |
| | Telescoped by direct pushing of double acting hydraulic cylinder together with by wire rope (With hydraulic automatic locking device) (2nd and 3rd sections extend sequentially, 4th, 5th and 6th sections simultaneously) |
| Boom derricking | Direct pushing by hydraulic cylinder (With hydraulic automatic locking device) |
| Hoisting | Hydraulic motor: Swash plate type axial piston pump |
| | Reduction gears: Spur-gear reduction+Differential gear mechanism |
| | Brake: Automatic mechanical brake |
| Slewing | Hydraulic motor: Axial plunger type |
| | Reduction gears: Worm-gear+Spur-gear reduction (Supported by ball bearings) |
| | Brake: Worm self-lock |
| Hydraulic pump | Variable delivery piston pump |
| Hooking capacity | 6.0 t Number of slinging rope: 4 |
| Safety device | Safety valve for hydraulic circuit |
| | Hydraulic automatic lock |
| | Automatic stop for overwinding |
| | Overwinding alarm |
| | Slewing automatic lock |
| | Automatic stop for leaving minimum wire rope |
| | Load indicator (With angle meter) |
| | Alarm buzzer |
| | Interlock for crane-crawl operation |
| | Crane/outrigger interlocking device |
| | Checker for outrigger rotary set pin insertion |
| Level | |
| Weight | Approx. 7980 kg |



MAJOR SPECIFICATIONS

Crawling device

| | |
|----------------------------|--|
| Crawling | Endless rubber crawler |
| Crawler | 400mm × 72.5mm × 82links |
| Length of ground contact | 2275mm |
| Pressure of ground contact | 44.1kPa (0.45kgf/cm ²) |
| Crawling speed | Forward/Backward: 0~2.9km/h |
| Hill-climbing ability | 23° |
| Engine | Rated output 23.0kW/2500r.p.m (31.3PS/2500r.p.m) |
| Crawling | Independently driven by hydraulic power |
| Parking brake | Disc brake with hydraulic motor built-in |
| Starting engine | Electric starter |
| Fuel tank | Capacity: 74 liters |



MAJOR SPECIFICATIONS

Chart of net rated load (For main boom)

Net rated loads chart

| BOOM SECTION 1 | | | | | | | | | |
|--------------------------|-------------------------------|----------------|-----|-----|------|------|------|--|--|
| WORKING RADIUS(m) | | | 2.7 | 3.0 | 3.5 | 4.0 | 4.3 | | |
| NET RATED LOAD(t) | OUTRIGGERS EXTENDED TO | MAXIMUM | 6.0 | 6.0 | 5.45 | 4.85 | 3.95 | | |
| | | HALFWAY | 6.0 | 6.0 | 5.45 | 4.85 | 3.95 | | |
| | | MINIMUM | 6.0 | 6.0 | 5.45 | 4.55 | 3.75 | | |

| BOOM SECTION 1+2 | | | | | | | | | | |
|--------------------------|-------------------------------|----------------|-----|-----|------|------|------|------|------|------|
| WORKING RADIUS(m) | | | 2.0 | 3.0 | 3.5 | 4.0 | 5.0 | 6.0 | 7.0 | 7.2 |
| NET RATED LOAD(t) | OUTRIGGERS EXTENDED TO | MAXIMUM | 6.0 | 6.0 | 5.35 | 4.75 | 3.75 | 2.95 | 2.25 | 2.0 |
| | | HALFWAY | 6.0 | 6.0 | 5.35 | 4.75 | 3.75 | 2.45 | 1.7 | 1.55 |
| | | MINIMUM | 6.0 | 6.0 | 5.35 | 4.65 | 2.55 | 1.65 | 1.15 | 1.05 |

| BOOM SECTION 1+2+3 | | | | | | | | | | | |
|---------------------------|-------------------------------|----------------|------|------|------|------|------|------|------|------|------|
| WORKING RADIUS(m) | | | 2.7 | 4.0 | 5.0 | 6.0 | 7.0 | 8.0 | 9.0 | 10.0 | 10.1 |
| NET RATED LOAD(t) | OUTRIGGERS EXTENDED TO | MAXIMUM | 4.55 | 4.55 | 3.65 | 2.95 | 2.4 | 1.8 | 1.35 | 0.95 | 0.95 |
| | | HALFWAY | 4.55 | 4.55 | 3.65 | 2.55 | 1.75 | 1.3 | 0.95 | 0.7 | 0.7 |
| | | MINIMUM | 4.55 | 4.55 | 2.65 | 1.7 | 1.2 | 0.85 | 0.65 | 0.45 | 0.4 |

| BOOM SECTION 1+2+3+4 | | | | | | | | | | | |
|-----------------------------|-------------------------------|----------------|------|------|------|------|------|------|------|------|------|
| WORKING RADIUS(m) | | | 5.0 | 6.0 | 7.0 | 8.0 | 9.0 | 10.0 | 11.0 | 12.0 | 12.9 |
| NET RATED LOAD(t) | OUTRIGGERS EXTENDED TO | MAXIMUM | 2.95 | 2.55 | 2.15 | 1.85 | 1.5 | 1.2 | 0.95 | 0.8 | 0.45 |
| | | HALFWAY | 2.95 | 2.55 | 1.85 | 1.4 | 1.1 | 0.85 | 0.65 | 0.55 | 0.4 |
| | | MINIMUM | 2.75 | 1.85 | 1.3 | 1.0 | 0.75 | 0.55 | 0.43 | 0.33 | 0.24 |

| BOOM SECTION 1+2+3+4+5 | | | | | | | | | | | | |
|-------------------------------|-------------------------------|----------------|------|------|------|------|------|------|------|------|------|------|
| WORKING RADIUS(m) | | | 6.0 | 8.0 | 9.0 | 10.0 | 11.0 | 12.0 | 13.0 | 14.0 | 15.0 | 15.8 |
| NET RATED LOAD(t) | OUTRIGGERS EXTENDED TO | MAXIMUM | 2.35 | 1.7 | 1.4 | 1.2 | 1.0 | 0.85 | 0.7 | 0.6 | 0.5 | 0.4 |
| | | HALFWAY | 2.35 | 1.5 | 1.15 | 0.95 | 0.75 | 0.6 | 0.5 | 0.4 | 0.3 | 0.25 |
| | | MINIMUM | 1.95 | 1.05 | 0.8 | 0.65 | 0.5 | 0.4 | 0.3 | 0.23 | 0.17 | 0.13 |

| BOOM SECTION 1+2+3+4+5+6 | | | | | | | | | |
|---------------------------------|-------------------------------|----------------|------|------|------|------|------|------|------|
| WORKING RADIUS(m) | | | 8.0 | 10.0 | 12.0 | 14.0 | 16.0 | 18.0 | 18.6 |
| NET RATED LOAD(t) | OUTRIGGERS EXTENDED TO | MAXIMUM | 1.35 | 1.0 | 0.8 | 0.6 | 0.4 | 0.25 | 0.2 |
| | | HALFWAY | 1.35 | 1.0 | 0.65 | 0.45 | 0.3 | 0.2 | 0.15 |
| | | MINIMUM | 1.1 | 0.7 | 0.45 | 0.28 | 0.17 | 0.09 | 0.06 |



MAJOR SPECIFICATIONS

Points to notice, Rated load

- Net rated loads are performance when the crane is placed level and is based on actual working radius including boom deflection under loaded. Net rated loads are also based on strength and stability of the crane.
- 'Outriggers extended to maximum' means the state that the inner box is extended to the position where the 2nd ● mark is visible.
- 'Outriggers extended to halfway' means the state that the inner box is extended to the position where the 1st ● mark is visible.
- 'Outriggers extended to minimum' means the state that the inner box is extended to the position where the 1st ● mark is invisible.
- When each of 4 outriggers has been set to different extension, operate the crane by using the worst extended capacity.
- When each of boom sections being extended is exceeded even slightly, operate it by application of the capacity for the next boom section.
- Boom **1+2+3+4** means that the boom is extended to the position where the 1st \ mark on the 4th boom-section is visible.
- Boom **1+2+3+4+5** means that the boom is extended to the position where the 2nd \ mark on the 4th boom-section is visible.
- Operate the crane using the rated load capacity data under the boom extension of: **1+2+3+4** when the \ mark on the 3rd boom-section goes beyond the 2nd boom section, regardless of the displacement, **1+2+3+4+5** when the 1st \ mark on the side plate of the 4th boom-section goes beyond the 3rd boom-section, regardless of the displacement, **1+2+3+4+5+6** when the 2nd \ mark on the side plate of the 4th boom-section goes beyond the 3rd boom-section, regardless of the displacement.



MAJOR SPECIFICATIONS

Chart of net rated load (For extension job)

(UNIT:kg)

| BOOM ANGLE | TILT ANGLE | | | |
|------------|---|-----|---|-----|
| | 0° | 20° | 40° | 60° |
| 80° | 800 | 800 | 600 | 600 |
| 75° | 800 | 800 | 600 | 600 |
| 70° | 700 | 700 | 500 | 500 |
| 65° | 600 | 600 | 400 | 400 |
| 60° | 500 | 500 | PROHIBITED AREA OF CRANE OPERATIONS | |
| 55° | 400 | 400 | | |
| 50° | 300 | 300 | | |
| 40° | PROHIBITED AREA OF CRANE OPERATIONS | | | |
| 30° | | | | |
| 20° | | | | |
| 10° | | | | |
| 0° | PROHIBITED AREA OF CRANE OPERATIONS | | | |

Points to notice, Rated load

- Net rated loads are performance when the crane is placed level and is based on actual working radius including boom deflection under loaded. Net rated loads are also based on strength and stability of the crane.
- The charts shows the data when the crane is operated with no-load and shift due to deflection of boom is not considered.



MAJOR SPECIFICATIONS

Chart of net rated load (For searcher hook)

| WORKING RADIUS (m) | NET RATED LOAD(kg) | | |
|--------------------|--------------------------------|--------------------------------|-------------------------------------|
| | OUTRIGGERS EXTENDED TO MAXIMUM | OUTRIGGERS EXTENDED TO HALFWAY | OUTRIGGERS EXTENDED TO MINIMUM |
| 7.0 | 800 | 800 | 800 |
| 8.0 | 800 | 800 | 610 |
| 9.0 | 800 | 700 | 420 |
| 10.0 | 800 | 550 | 250 |
| 10.5 | 800 | 490 | 200 |
| 11.0 | 650 | 430 | 160 |
| 11.5 | 550 | 370 | 120 |
| 12.0 | 470 | 310 | 100 |
| 13.0 | 330 | 230 | PROHIBITED AREA OF CRANE OPERATIONS |
| 14.0 | 260 | 150 | |
| 15.0 | 210 | 100 | |
| 16.0 | 170 | | |
| 17.0 | 130 | | |
| 18.0 | 100 | | |
| 20.8 | | | |

Points to notice, Rated load

- Net rated loads are performance when the crane is placed level and is based on an actual working radius including boom deflection under loaded.
- Net rated loads are also based on strength and stability of the crane.
- Net rated loads must be reduced in accordance with wind, ground condition and operation speed.
- In order to make correct operation, read the instruction manual carefully before crane operation.

MAJOR SPECIFICATIONS

● **How boom-sections are extended**

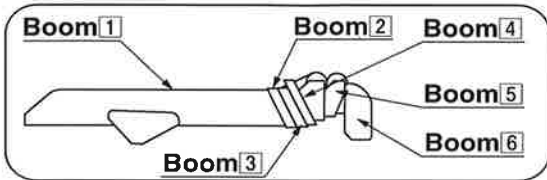

Boom : **1**

All boom sections are retracted.

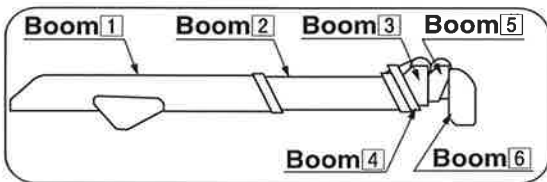

Boom : **1+2** or **2**

Boom section(2) only is extended.

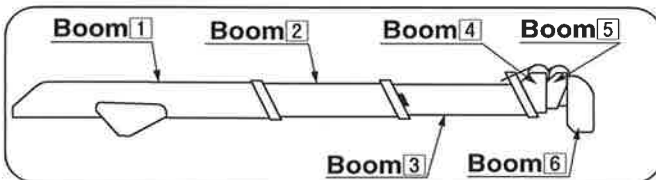

Boom : **1+2+3** or **3**

Boom sections(2) and (3) extended to a position where the mark **∧** on the boom section (3) is visible.

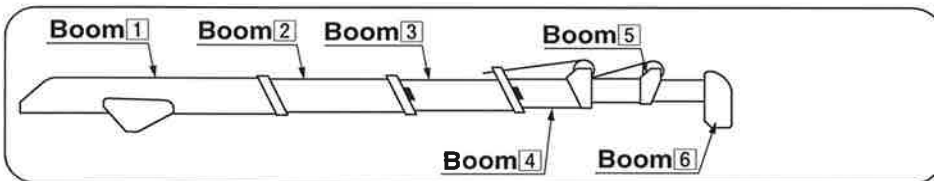

Boom : **1+2+3+4** or **4**

Boom sections are extended to a position where 1st mark **∧** on the boom section (4) is visible.

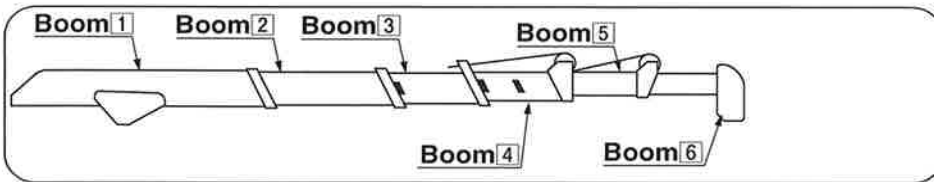

Boom : **1+2+3+4+5** or **5**

Boom sections are extended to a position where 2nd mark **∧** on the boom section (4) is visible.

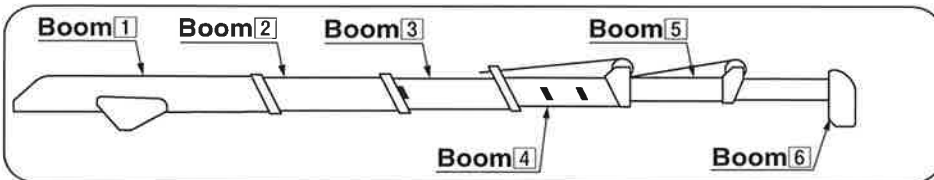

Boom : **1+2+3+4+5+6** or **6**

Boom sections(2), (3), (4), (5), and (6) are fully extended.



MAJOR SPECIFICATIONS

2 Major specification (Radio remote control device)

| | |
|--|--|
| Model | RC-500HA-AUS, Radio remote control device |
| Applied radio wave law | Specified small power radio station |
| Radio frequency | 433 ~ 434 MHz band |
| Transmission output | 10 mW |
| Frequency selection | Auto-scanning (automatic selection) |
| Service range of radio wave | 100m min. (when in good conditions with no radio interference) |
| System structure | Combined system of manual and radio remote control operation |
| Controls (functions operated through radio control transmitter) | |
| | Selector switches: |
| | Boom :Up/Down (Crane mode/Outrigger mode) |
| | Hook :Up/Down |
| | Boom telescoping :Extend/Retract (P ON/OFF/OR Horizontal/vertical) |
| | Slewing :C.C.W./C.W. (Start/Stop) |
| | Store hook :Storage |
| | Speed selector switch: |
| | Selection of speed modes : High/Medium/Low speed |
| | Mode switch :Switching each function by combination of selector switch |
| | Horn switch :Alarm (Horn on mounting vehicle) |
| | Speed lever :Both hydraulic control and engine speed control |
| Power supply | Battery on mounting vehicle (DC 12V) Transmitter: a size AAA battery: 4 pieces |
| Power consumption | Crane :When operating single function at maximum speed, approx. 50W, 120W max. (including control box) Transmitter (service life with alkaline batteries) :20 hours min. |
| Voice messages | “Crane mode” “Remote control ready” “Stop winch up” “Secure lifting hook” “Low transmitter battery” “Service remote control” “Change control mode” |
| Operating temperature range | -20°C~+60°C |
| Storing temperature range | -30°C~+75°C |
| Weight of transmitter | 700g (including batteries) |

★ The radio remote control device employs a unique data transmission system and an ID (identification) code is assigned to each equipment.

Therefore, the crane will not be worked by radio wave radiated from other radio equipment.

★ About auto-scanning system :

Auto-scanning system is a system that changes the current frequency to other frequencies automatically to avoid radio interference when a similar radio wave is being radiated nearby.

18. MODE INDICATOR LAMP (Control Box)

1 Mode indicator lamp (Control box)

The "mode indicator lamp" is mounted in the control box indicating conditions of crane operation and troubles in detail.

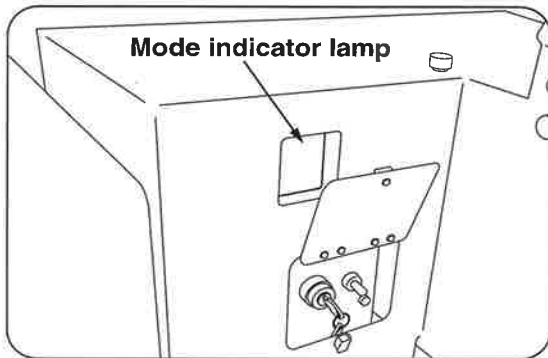

When the "mode indicator lamp" lights, the crane system is working normally.

When the "mode indicator lamp" blinks, the crane system is in a trouble or prohibited operation is being carried out.

◆1. Mode indication when crane is in normal operation

It indicates each operation mode and condition of the crane when it is normal. Description of mode indication when it is in normal is as follows:

Mode indication when crane is in normal condition (lighting indication)

| Mode | Mode description | Radio control operation mode | Manual operation mode | Priority |
|----------|---|------------------------------|-----------------------|----------|
| 0F | Current control is on traveling mode. No operation other than traveling is possible either by manual control or by radio remote control. | × | × | 1 |
| 00 | Current control is on normal crane operation mode. Operation is possible by radio remote control. | ○ | × | 9 |
| 01 | Current control is on normal crane operation mode. Operation can only be carried out manually but not through radio remote control device. | × | ○ | 9 |
| 04 05 | Current operation is in outrigger radio control mode. Extension and retraction of outriggers can only be possible by manual control when in manual control mode or by radio remote control when in radio remote control mode. Operation other than the above is impossible either by manual or by radio remote control. | ○ | × | 5 |
| | | × | ○ | |
| 06 | Current control is on low temperature operation mode. Operation can be carried either by manual control or by radio remote control device. | (○) | (○) | 8 |



MODE INDICATOR LAMP (Control Box)

| Mode | Mode description | Radio control operation mode | Manual operation mode | Priority |
|------|--|------------------------------|-----------------------|----------|
| 07. | Current control is on low temperature operation mode. Operation can be carried by manual control but not through radio remote control. | × | ○ | 8 |
| 10 | Hook hits against weight for over-winding alarm (over-wound condition). | — | — | 7 |
| 13 | During operation of storing hook. | — | — | 6 |
| 14 | Automatic stop for over-winding reset switch is being controlled | — | — | 4 |
| 15 | Outriggers fail to touch the ground or overturn threshold alarm is actuated (URW series only). | — | — | 2 |
| 16 | Outriggers fail to be set up on the ground securely or overturn prediction alarm is actuated (URW series only). | — | — | 3 |

●Remarks

Since priority is assigned for each mode description, it is to be indicated in the order of higher priority.

If the [.] (dot) is indicated on the bottom right of “mode indicator lamp”, it means the “radio control OFF” mode.

Crane cannot be operated through radio control transmitter.

When operated on outrigger radio control mode, crane operation other than extension/retraction of outriggers cannot be carried out.

When the shock-less function has been cancelled, the letter on the left indicated in the mode indicator changes to [-].

Refer to page 12-21 for detail.



MODE INDICATOR LAMP (Control Box)

◆2. Mode indication when crane is in trouble

When the “mode indicator lamp” is blinking figures larger than [42] (or [54] lights), the crane system is in trouble (system trouble indication).

If the system trouble indication is found on the “mode indicator lamp”, confirm and follow the mode description on the table illustrated below:

If the crane becomes impossible to be operated, store the crane by following procedures described in section 12. ⑧ “◆5. Operation in an emergency” (on page 12-41), and ask an authorized UNIC service shop for repair.

Mode description when crane is in trouble (Blinking indication)

| Mode | Mode description | Radio control operation | Manual operation |
|----------------|---|-------------------------|------------------|
| 42~46 | No operation is possible either by radio control or by manual control. | × | × |
| 47~50 | Turn OFF power once then turn it ON. If the trouble persists, ask an authorized UNIC service shop for repair. (Although it can be operated either by radio control or by manually, shock-less function returns to be “active”.) | ○ | ○ |
| 51~53 | No radio control operation is possible. | × | ○ |
| 54 (Lights) | Radio control receiver is not connected. Check that cable connector (located inside switch box) of receiver is securely connected. Check cable to receiver for damage and break. | × | ○ |
| 55 | Either “mode selector switch”, “hook storing switch” or “radio control selector switch” in the control box is faulty. (Failed switch cannot be controlled but crane operation is possible.) | ○ | ○ |
| 56 | No operation is possible either by radio control or by manual control. | × | × |
| 57 | No operation is possible either by radio control or by manual control. Turn OFF power once then turn it ON again. | × | × |
| 58 | Radio control operation cannot be possible and engine speed control and safety devices will not function. | × | ○ |
| 59 | “Emergency stop switch” has been depressed. If this is indicated even when the “emergency stop switch” has not been depressed, ask a UNIC service shop for repair. | × | × |



MODE INDICATOR LAMP (Control Box)

| Mode | Description of wrong operation | Measures to be taken |
|------|---|--|
| 10 | Either one of operation such as "boom Up", "hook Up", or "boom Extend" (when operated on para-hook mode) is being carried out while hook has hit against weight for over-winding alarm. | Detach hook from weight for over-winding alarm. ●When raising boom through radio control device with hook hit against the weight for over-winding alarm, boom is to be "Up" while hook is winding "Down" as this operation allows hook to be released. Do not lift up a cargo while this is being indicated. |
| 90 | Emergency stop switch on the remote control device is pressed. | Release the emergency stop switch when operating crane. |
| 96 | Operation of winding down hook is carried out while the sensor detecting minimum wire rope is being activated. | Stop winding down hook and wind it up so that the sensor detecting minimum wire rope will not be activated. |
| 97 | In the boom/outrigger interlocking device, outrigger operation is being carried out without boom being stored. | Stop outrigger operation without boom being stored. Operate outriggers after boom has been stored. |



19. MEASURES TO BE TAKEN IN AN EMERGENCY

Take measures when the crane does not operate correctly even if the “mode indicator” is indicating right.

| Trouble | Possible cause | Measure to be taken |
|--|--|---|
| Crane fails to be operated by radio remote control device. | Batteries in transmitter have been run out or they are not loaded. | Replace batteries in transmitter. |
| Crane works just when a selector switch on transmitter is actuated. | Speed lever of radio control transmitter is faulty. | Repair radio control transmitter at a UNIC authorized service shop. |
| Crane works arbitrarily even when no controls have been made or a manual control lever has been shifted. | A solenoid valve of control valve is in failure. | Depress EMERGENCY stop switch to stop crane operation immediately. Tighten the emergency screw clockwise lightly to its extreme. (Pay attention that the screw may break if it is tightened with an excessive force.) Depress EMERGENCY stop switch again to reset emergency stop. Check that crane does not work when no controls have been made. Store crane with manual levers and ask a UNIC authorized service shop for replacement of faulty solenoid valve. |

● Remarks

The emergency screw is fixed with a lock pin.
Remove the lock pin before turning the emergency screw.

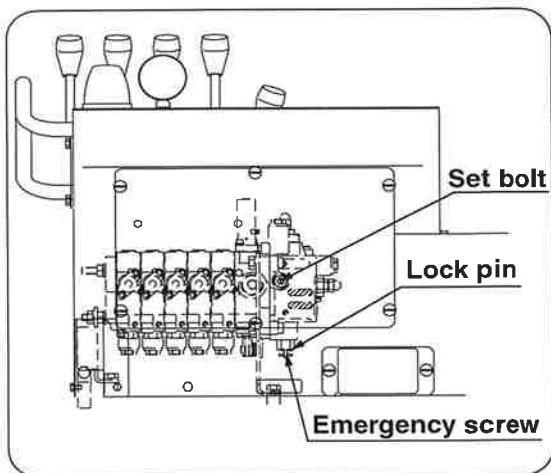



FURUKAWA UNIC CORPORATION

HEAD OFFICE : Nihonbashi nishikawa Bldg, 5-3, Nihonbashi
1-chome, Chuo-ku, Tokyo 103-0027, Japan